

**Engine Room Simulator**  
**ERS L11 5L90MC – VLCC**  
Version MC90-V

**Operator's Manual**

**Part 3**

**Machinery & Operation**



## TABLE OF CONTENTS

Section	Page
<b>1 SEQUENCE DIAGRAMS .....</b>	<b>2</b>
1.1 First start to own supply .....	2
1.2 Own supply to harbour condition .....	3
1.3 Harbour condition to ready for departure .....	4
1.4 Manoeuvre mode to sea passage mode .....	5
<b>2 ELECTRICAL PLANT .....</b>	<b>7</b>
2.1 Electrical Power Plant MD70.....	7
2.2 Diesel Generators MD75.....	13
2.3 Synchroscope MD142 .....	19
2.4 Shaft Generator/Motor MD77.....	21
2.5 Main Switchboard-Starter section MD71 .....	25
2.6 Main Switchboard-Feeder section MD72 .....	27
2.7 Emergency Switchboard MD73.....	29
<b>3 MAIN ENGINE AND MAIN ENGINE SYSTEMS .....</b>	<b>31</b>
3.1 Main Engine.....	31
3.2 ME Lubrication Oil System MD12 .....	35
3.3 ME Bearings MD29 .....	39
3.4 ME Cylinders MD21.....	43
3.5 ME Piston Ring Monitor MD27 .....	45
3.6 Fresh Water Cooling System MD10 .....	47
3.7 Fuel Oil System MD11.....	51
3.8 ME Fuel Oil High Pressure System MD28 .....	57
3.9 ME Turbocharger System MD13 .....	59
3.10 ME Selective Catalytic Reduction MD14 .....	63
3.11 ME Local Control MD20 .....	67
3.12 ME Manoeuvring System MD18 .....	71
3.13 Cylinder Indications MD120 .....	75
3.14 Load Diagram MD128 .....	85
<b>4 PROPELLER AND STEERING GEAR SYSTEMS MD53 .....</b>	<b>89</b>
4.1 Propeller Servo Oil System MD53 .....	89
4.2 Stern Tube System MD54.....	91
4.3 Steering Gear System MD58.....	93
<b>5 SERVICE SYSTEMS .....</b>	<b>99</b>
5.1 Main Sea Water System MD01 .....	99
5.2 Air Ventilation System MD40 .....	103
5.3 Air Conditioning Plant MD41 .....	105
5.4 Starting Air Compressors MD59 .....	109



---

5.5	Service Air Compressors MD60 .....	113
5.6	Fuel Oil Transfer System MD03 .....	117
5.7	Fuel Oil Service Tanks MD05.....	119
5.8	Fuel Oil Settling Tanks MD04 .....	123
5.9	HFO Separator System MD06 .....	127
5.10	Diesel Oil Separator System MD08 .....	131
5.11	Lubrication Oil Purifier System MD09 .....	135
5.12	Fresh Water Generator MD61.....	139
5.13	Fresh Water Hydrophore System MD67 .....	143
5.14	Bilge System and Bilge Separator MD62 & MD63.....	144
5.15	Refrigeration System MD64 .....	155
5.16	Sewage Treatment MD 45 .....	159
5.17	Steam Generation Plant MD80 .....	163
5.18	Exhaust Boiler MD81 .....	167
5.19	Oil Fired Boiler MD82 .....	169
5.20	Boiler Combustion MD84 .....	173
5.21	Steam Condenser MD85.....	179
5.22	Turbo Generator MD86 .....	181
5.23	Cargo Pump Turbines MD87 .....	185
5.24	Ballast Water System MD89 .....	189
5.25	Inert Gas Plant MD91 .....	193
5.26	Deck Machinery MD97 .....	197
<b>6</b>	<b>SIMULATOR &amp; SHIP MODEL PARTICULARS .....</b>	<b>201</b>
6.1	Propeller and Ship Model Characteristics .....	201
6.2	Ship Load MD57.....	203
6.3	Ambient Temperatures .....	204
6.4	Auto Pulsar System .....	205



**The Process diagrams presented on the monitors have the following colour codes for pipelines:**

- Blue: Fresh water (low and high temperature)
- Green: Sea water
- Yellow: Diesel oil
- Brown: Fuel oil
- Light brown: Lubrication oil
- Grey: Start and service air
- Light blue: Steam

The Process Diagrams are abbreviated T, G, P, etc.; meaning:

- T: Temperature
- G: Flow
- P: Pressure
- N: Rpm
- Q: Power
- I: Ampere
- U: Voltage
- F: Frequency
- E: Electrical power
- V: Valve
- L: Level
- X: Miscellaneous variable
- Z: Water or other undesirable contamination index variable
- W: Viscosity

# 1 SEQUENCE DIAGRAMS

## 1.1 First start to own supply

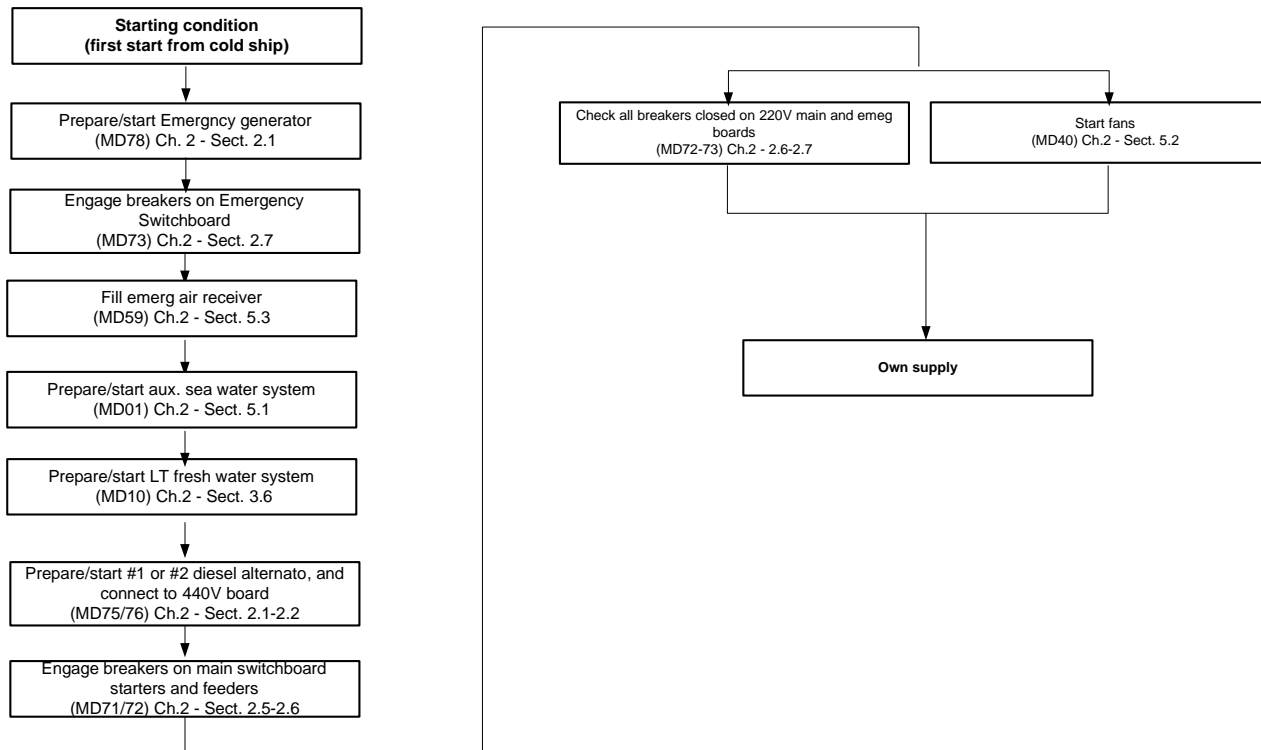

## 1.2 Own supply to harbour condition

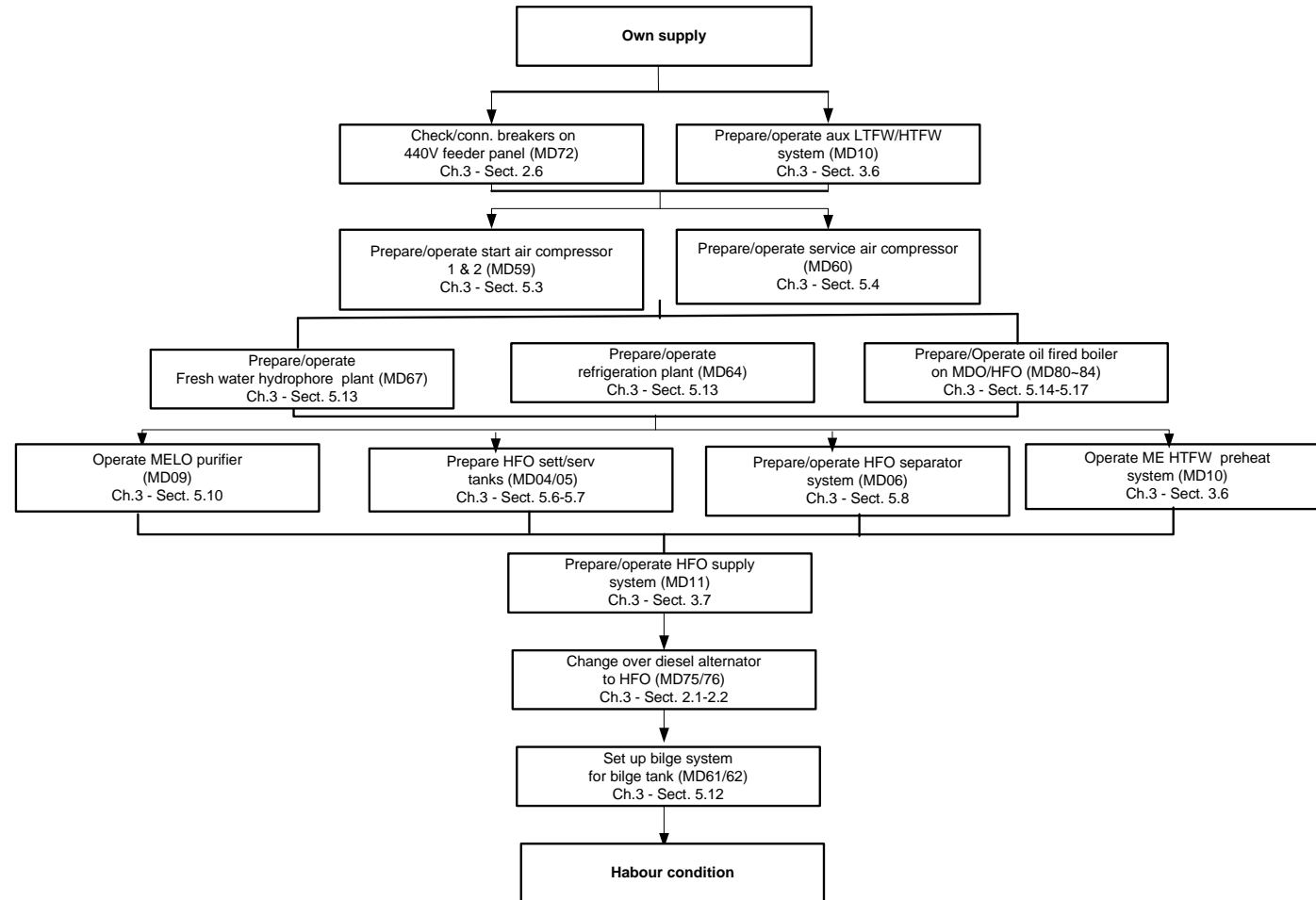

### 1.3 Harbour condition to ready for departure

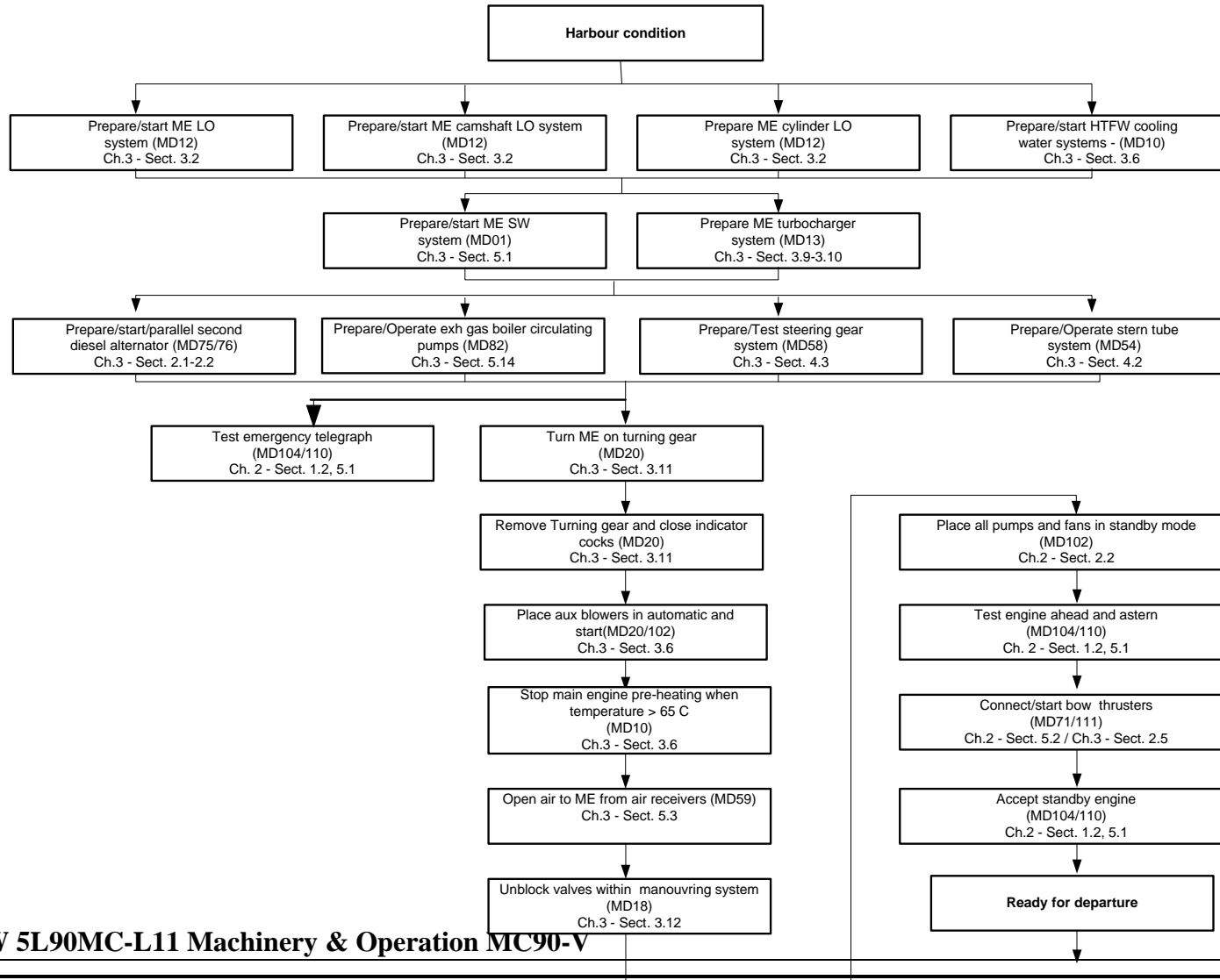



## 1.4 Manoeuvre mode to sea passage mode

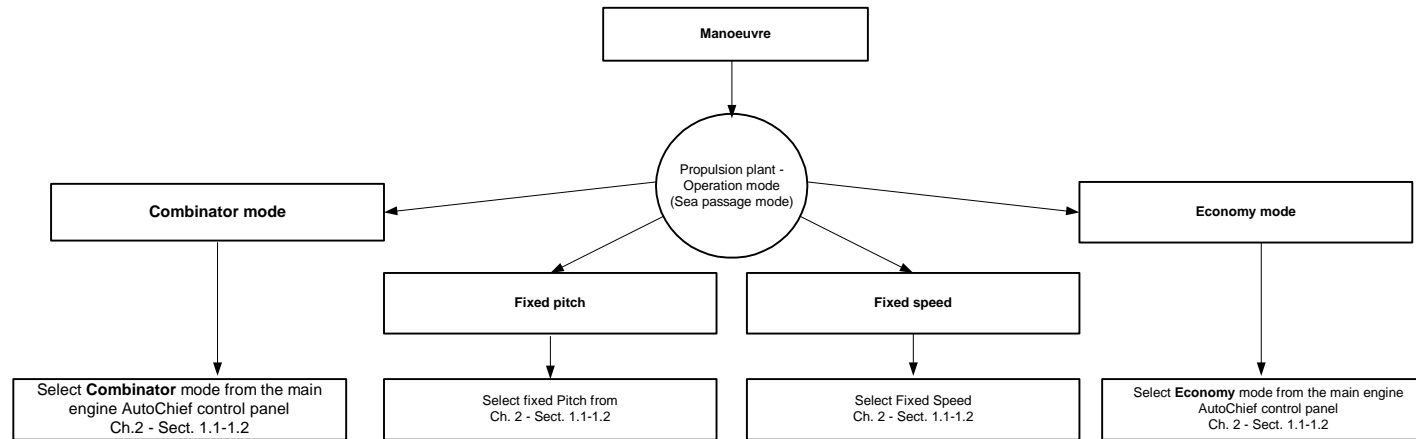

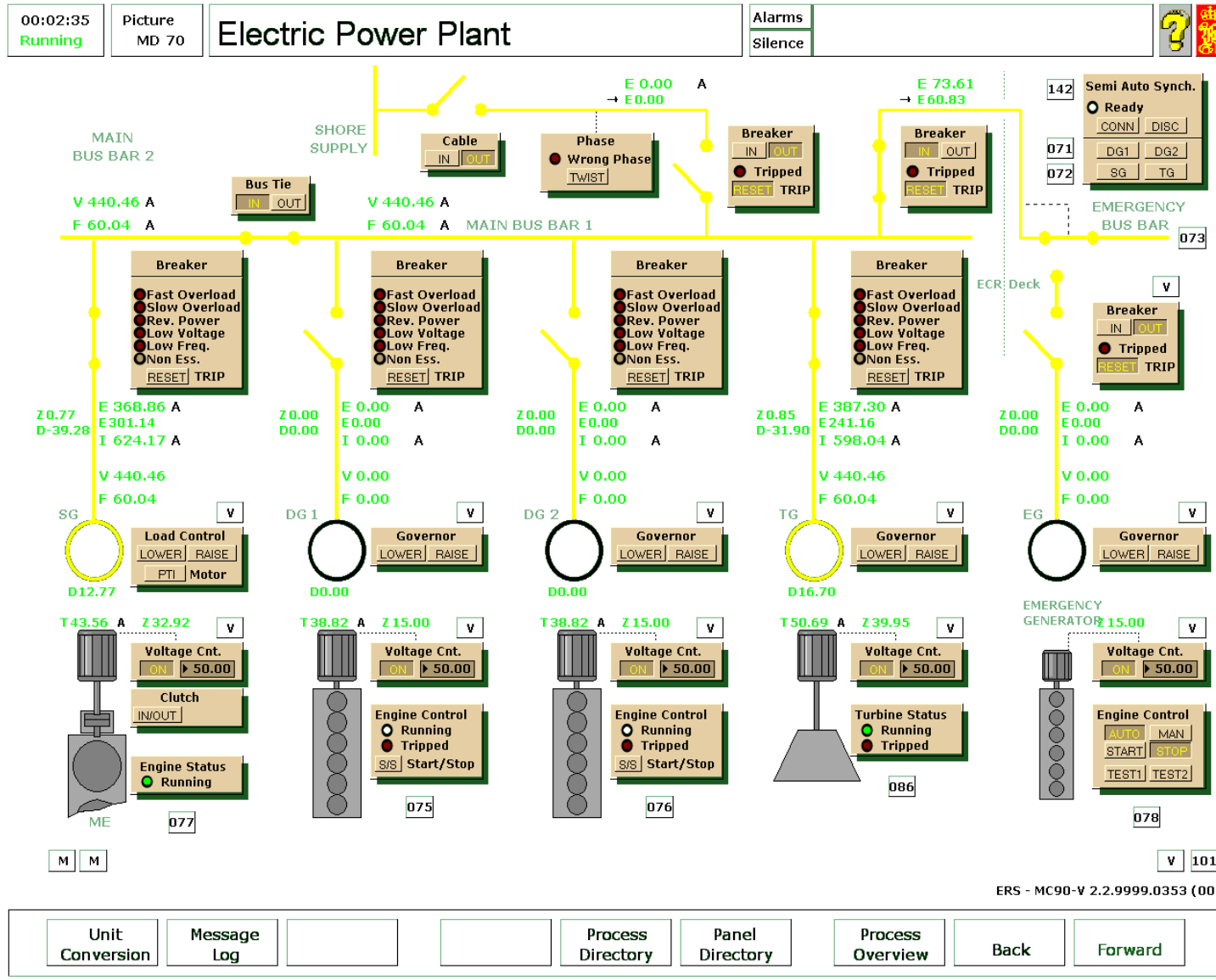

## 2 ELECTRICAL PLANT

### 2.1 Electrical Power Plant MD70

#### General

The ship's electric power is generated by:

- two diesel engine driven synchronous generators - diesel generator 1 (DG1) and diesel generator 2 (DG2 )
- one turbine driven generator.
- one propeller shaft driven synchronous generator, with power take in facility.
- one emergency generator

and distributed via:

- one main switchboard, divided into two main 440V bus bars
- one 220v bus bar
- one emergency bus bar
- one 220v emergency bus bar

Bus bar 1 powers all the electrical main consumers and the emergency bus bar.

Bus bar 2 powers the bow thruster and the heavy deck machinery.

The 220v bus bar is supplied from bus bar 1 via a circuit breaker and transformer.

The emergency switchboard supplies the emergency 220v bus bar via a circuit breaker and transformer. Emergency batteries are supplied by two battery chargers, one for starting battery and one for emergency supplies.

The bus bars can also be supplied via a shore connection link that has the ability to alter phase rotation to ensure that motors turn in the correct direction.

#### Description

The status of all prime movers is indicated, with the diesel generators having a remote start available.

The emergency generator can be set to either AUTO or MAN mode. It is normally kept in AUTO. Test 1 starts the generator, test 2 connects the breaker while disconnecting the emergency bus bar from the main bus bar. In AUTO mode if power is lost to the emergency bus bar the generator starts and connects automatically. Reconnecting the emergency bus bar to a live main bus bar automatically stops the generator.

The shaft generator can be connected to the main engine by operating the clutch. The clutch will not close if the PTI shaft speed is above 300rpm.

Each generator is excited by an AVR based on a PI controller. Changing the excitation setting alters the controller base setting.



Each main generator has indication for rotor phase (between current and voltage), current angle, power factor and reactive power.

The main generators governor speed control and shaft generator load control can be accessed. All are based on a PI controller with droop setting.

The shaft generator can be used as a power take in (motor) in case of main engine problems so that propulsion can be maintained.

All main generators are protected by a circuit breaker. The breaker protects against:

- Fast overload
- Slow overload
- Reverse power
- Low voltage
- Low frequency

The settings of the above are easily accessed on the breaker itself. The breaker also sets the level at which the preferential trips operate, this function does not trip the circuit breaker. Whichever trip has activated is indicated and can be reset from the circuit breaker. The emergency generator can not be synchronised, its breaker are accessed via variables page 7822.

On the main bus bar there is a connection to the emergency bus bars, a bus tie for main deck machinery and a shore connection availability.

### **Normal operating modes.**

Emergency generator on AUTO at all times.

- In port.
  - diesel generators supplying power as required, normally one is sufficient.
  
- Manoeuvring.
  - Fixed pitch operation.
    - both diesel generators supplying all electrical power.
  - Variable pitch operation.
    - both diesel generators supplying main bus
    - bus tie open
    - Shaft generator supplying power to bow thruster.
  
- Sea passage
  - Turbine out of action
    - Turbine generator supplying all power
    - Shaft generator in PTI
  - Shaft generator supplying power to bow thruster.



## **Operation**

### **1. Shore Connection.**

- 1.1 Ensure all generators disconnected, emergency bus bar and bus tie disconnected.
- 1.2 Connect incoming cable.
- 1.3 Check phase rotation, use phase twist if required.
- 1.4 Close shore circuit breaker to supply main bus.
- 1.5 Close emergency bus if required or starting from cold and continue start sequence.
- 1.6 Shore circuit breaker must be tripped before connecting main generator to bus.

### **2. Emergency Generator Starting**

- 2.1 Ensure battery voltage is correct. MD73 or 78. V72691.
- 2.2 If battery voltage to low, use the EM hydraulic start.
- 2.3 Generator in manual operation press start.
- 2.4 Turn on voltage control and adjust to 440v.
- 2.5 Use governor control to give 60Hz output.
- 2.6 Connect emergency generator breaker.
- 2.7 Trip main bus breaker connection to emergency bus.

### **3. Emergency Generator Stopping**

- 3.1 Ensure that main bus bar has supply.
- 3.2 Connect main bus bar breaker connection to emergency bus.
- 3.3 Open emergency generator breaker.
- 3.4 Stop generator.

### **4. Emergency Generator Automatic Operation**

- 4.1 The generator is normally in AUTO, voltage control on, circuit breaker open.
- 4.2 If supply is lost to the emergency switchboard the generator will automatically start and close the circuit breaker supplying the emergency bus.
- 4.3 The main bus will be isolated due to the connection circuit breaker opening on low voltage.
- 4.4 When the emergency bus is again supplied from the main bus, connection circuit breaker closed, the emergency generator will automatically stop and open the circuit breaker.

### **5. Emergency Generator Testing**

- 5.1 The generator should be tested regularly to ensure that it will function when required.
- 5.2 With the generator in AUTO, TEST 1 will simulate low voltage on the emergency bus causing the generator to start.
- 5.3 The generator will attempt a maximum of three starts.
- 5.4 Releasing TEST 1 the generator stops.
- 5.5 Before using TEST 2 the bridge must be informed and check that the elevator is not in use. TEST 2 will temporarily interrupt the emergency supply.
- 5.6 TEST 2 disconnects the emergency bus from the main bus simulating total supply failure, the generator starts and supplies the emergency bus.
- 5.7 Releasing TEST 2 reconnects the emergency bus to the main bus and the generator stops.



## 6. Main Generators

- 6.1 It is normal to have the generators in AUTO, (MD101), and priorities set on shaft and diesel generators so that load sharing is achieved as the control mode dictates.
- 6.2 The Turbo generator will always be priority one when running.
- 6.3 With generators not in AUTO mode connection can be made from MD70.
- 6.4 Before attempting connection check that the generator is ready to run. (MD75, MD76, MD86).
- 6.5 The turbo alternator must be running before connection can be attempted.
- 6.6 Ensure that voltage control is on.
- 6.7 Start required generator by pressing start/stop button.
- 6.8 When engine is running adjust voltage control if necessary to match main bus voltage.
- 6.9 The breaker can be made by the semi auto sync – select generator and adjust speed until ready light shows, press conn.
- 6.10 Manual synchronising can be carried out from the main switchboard (MD140 – MD144).
- 6.11 Once connected the generators must be manually balanced by adjusting the governor controls.
- 6.12 To disconnect select generator to be stopped, remove load by lowering the governor control, press disc.
- 6.13 After disconnection, the generator can be stopped by pressing the start/stop button.
- 6.14 The turbo generator must be stopped from MD86.

## 7 Shaft Generator, Power Take Off mode

- 7.1 Ensure that the shaft generator is ready on MD77. Auxil. Power, Synch. Cond. On and air valve open. Clutch control in local.
- 7.2 Ensure voltage control is on.
- 7.3 Engage clutch. Clutch will not engage if input drive speed is greater than 300 rpm.
- 7.4 Adjust voltage control if necessary.
- 7.5 Use Semi Auto Synch. to select SG and raise/lower load control until ready light is on.
- 7.6 Press connect and raise load as required.
- 7.7 Manual synchronising can be carried out from the main switchboard (MD140 – MD144)..
- 7.8 To disconnect, select SG, reduce load to zero and press Disc.

## 8 Shaft Generator, Power Take In mode

- 8.1 To enable power take in the reverse power setting of the breaker is set to –1500kW.
- 8.2 Breaker must be connected in PTI mode.
- 8.3 Press PTI.
- 8.4 The shaft generator load is gradually reduced and PTI mode initiated.
- 8.5 PTI may be adjusted using the Lower and Raise load control.
- 8.6 To change from PTI to PTO press PTO. Power in is reduced to zero.
- 8.7 Disconnect breaker or adjust load to supply power from SG.

<This page is intentionally left blank>

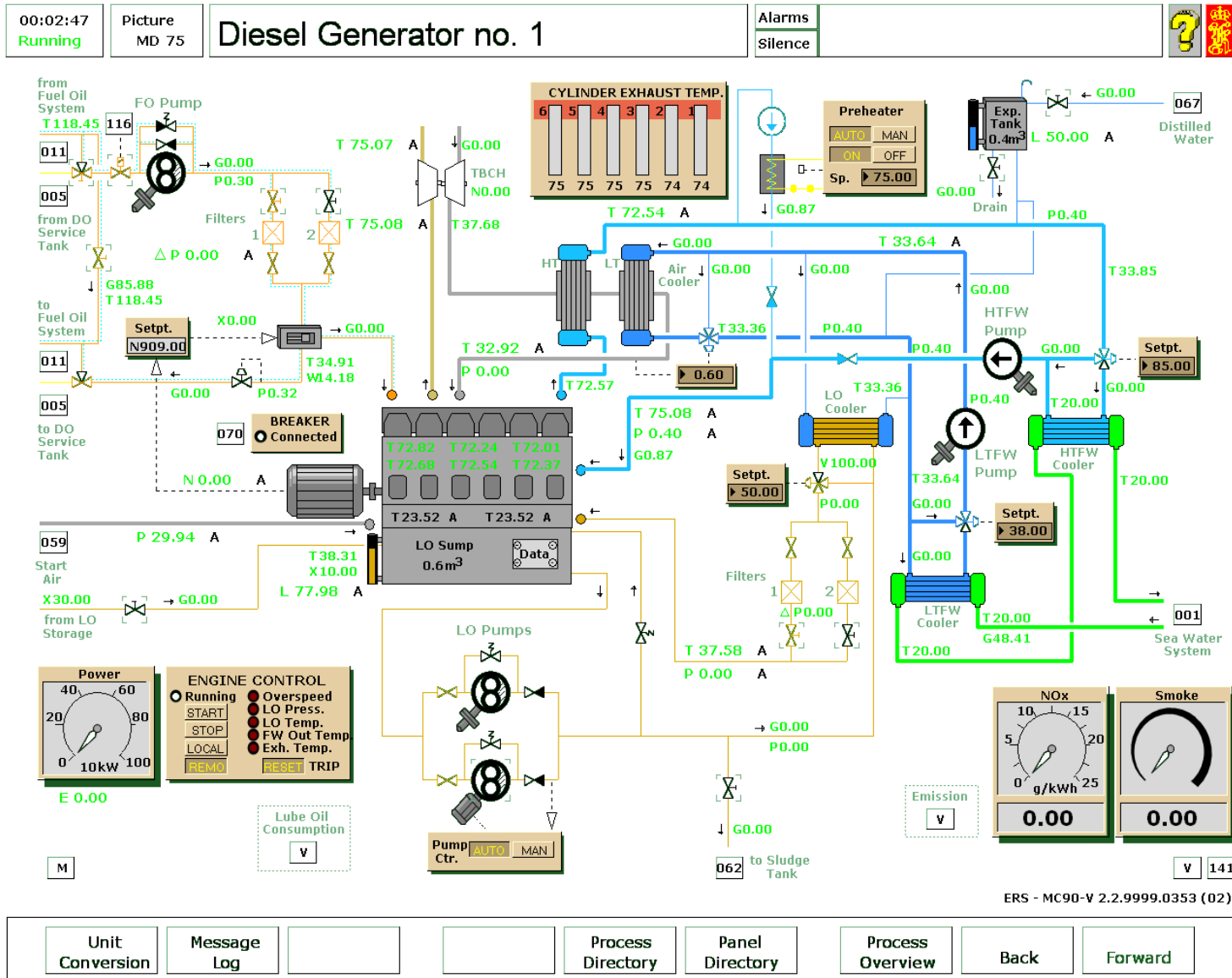



## 2.2 Diesel Generators MD75

### General

The ship is equipped with two 900kW/850kVA/440V/60Hz/900 rpm synchronous main generators. Each generator is driven by a turbocharged, four-stroke, 6-cylinder auxiliary diesel engine (DG1 and DG2)

The auxiliary diesel engines are equipped with separate, integrated systems for cooling water and lubrication oil.

The diesel engines are designed for both diesel and heavy fuel oil operation (700 cSt).

In order to prevent carbonising and heavy smoke emission during low load, the fresh water cooling system is arranged in such a way that the scavenge air is heated during low load.

### Description

The engine is equipped with a shaft driven fuel oil pump. The pump takes suction either from the fuel oil supply system or direct from the diesel oil service tank. Shifting between diesel oil and fuel oil is carried out by means of the double 3-way valve, shifting both supply and return direction.

The piping from Fuel supply system (MD11) to the diesel generators (MD75/76) can be heated by steam tracing and is also kept hot by fuel recirculation at each generator. To keep the fuel injection pumps hot, a non-return fuel circulation valve is mounted in parallel with the fuel pump, also a pressure control valve in the fuel return line is included. The fuel quality at injection pumps is indicated. For a safe start the viscosity at injection pumps should not be higher than 17-18 cSt. If a change-over is made from HFO to DO while the engine is running, there will be a short loss of

power, but the engine will keep running. A change-over to HFO while the engine is running on DO will cause missfiring/engine stop due to too low temperatures of the metal part in the fuel feeder line and injection pumps. The fuel oil pump discharges to the high-pressure pump header through a duplex filter. Surplus oil is returned to the diesel oil service tank or the fuel oil system depending on the position of the double 3-way valve.

An electrically operated shut-off valve on the suction side of the fuel oil pump shuts off the fuel oil supply in case of an emergency. The valve is controlled from the Remote Emergency Operating Panel.

The lubrication system is equipped with an electrical oil pump and a shaft driven main lubrication oil pump. The electrical pump serves as a pre-lubrication oil pump and as a stand by oil pump in case of break down of the shaft driven main pump. The pumps take suction from the diesel engine lubricating oil sump and discharges through a freshwater cooled oil cooler and a duplex filter. The oil sump can be refilled from the lubricating oil storage and the oil can be drained to the sludge tank by using the electrical oil pump.

The electrical oil pump can be operated in manual or in automatic mode.

Seawater for the LT and HT fresh water coolers is provided by the vessel's main sea water system.

A shaft driven LT fresh water circulating pump circulates fresh cooling water through the lubricating oil cooler and the scavenging



air cooler. A shaft driven HT fresh water circulating pump circulates the scavenge air heater and cylinder jackets. The temperature is controlled by a simple proportional controller, controlling the temperature at inlet cylinder jackets. The HT can be pre-heated, using an electric heater.

The governor (rpm controller) settings are available in a pop-up window with the following variables:

- Speed-droop (speed controller droop setting): Default setting = 60%, which represents a speed droop approx. 3%, or 1.8Hz. 100 % = approx. 5% speed droop.
- Speed set point (basic speed at unloaded engine): Default setting = 909 rpm.
- Load limit (speed controller max. Output limit): Default setting for the “maximum fuel lever position” = 100%.
- Compensation lever (speed controller gain): Default setting for the proportional gain is set to 65.
- Compensation valve (speed controller integral time): Default setting = 20 seconds.
- The governor response at different settings can be studied by means of the pop-up TREND window.

**NOTE!** Frequency regulation stops when the Engine is overloaded (when alarm is activated).

The FW temperature controller is a proportional gain controller with BIAS setting. BIAS default setting is 50%, which means that 50% is added. (Deviation \* P-Gain) + BIAS = Output.

The pre-lubrication pump: Interval lubrication with default setting: 8 seconds on and 20 seconds off. The pre-lubrication pump will

stop when the diesel starts, if lubrication oil pump control is set to AUTO, and start when the diesel engine stops. The Engine Control Panel has the following functions and indications:

- Selection of local/remote control of engine
- Start/stop of engine
- Trip indications
- Reset of trip

### Safety System

The diesel engines are equipped with a separate, independent safety system acting as a back-up system to the safety system of the PowerChief. The system monitors the engine condition by binary sensors and includes the following adjustable parameters:

Parameter	Normal setting
Over speed	112%
Low Lub Oil Pressure	1,0 bar
High Lub Oil Temp.	90°C
High fresh water Temp.	96°C
High Exhaust Temp.	700°C

If one of the parameters is exceeded the diesel engine will shut down and a trip alarm is given. A lamp at the local panel indicates the trip condition. To restart the engine the cause must be found and corrected and the safety system must be reset by pushing the RESET button.

The trip limits can be inspected and changed from the variable page 7515/7615.



## Operation procedure

In normal operation the generator is in stand by mode with AUTO and priority selected on the POWER CHIEF. While in AUTO mode the generator must be prepared ready to start.

### 1. Preparation

- 1.1 Check level in the fresh cooling water expansion tank and refill if necessary.
- 1.2 Check that the fresh water temperature controller is working and in AUTO – normal set point is 85°C
- 1.3 Ensure sea water valve to cooler is open pump, MD01, and sea water flow is normal.
- 1.4 Check level in lubricating oil sump tank, (min 40%) - refill from storage tank if necessary
- 1.5 Line up lubrication oil system. Normally one filter is in operation and one filter is cleaned and on stand-by.
- 1.6 Ensure that lubrication oil valve to the sludge tank is closed.
- 1.7 Start the electrically driven lubricating oil pump (pre-lubrication oil pump), and check that the oil pressure is increasing.
- 1.8 Set the electrical lubricating oil pump in AUTO mode by pressing the AUTO button on the PUMP. CTR. panel.
- 1.9 Check water level in the fuel oil service tanks and drain if necessary.
- 1.10 Ensure that fuel oil supply valves from diesel oil service tank, MD05, and fuel oil system, MD11, to generator engine are open.

- 1.11 Open fuel oil inlet valve to fuel oil pump.
- 1.12 Open fuel oil valve before fuel oil filters. Normally one filter is in operation and one filter is cleaned and on stand-by.
- 1.13 Check the position of the fuel oil supply 3-way valve.
- 1.14 Open start air valves, MD59. Start air must be at least 15 bar (218 psi) on the starting air line.
- 1.15 If any of the alarm lamps (red) at the local panel are lit, press the RESET button.
- 1.16 Start the engine from the local panel by pressing the START button.

### 2. Starting

- 2.1 When the Engine Control panel is in Remote the engine can only be started from the POWER CHIEF panel or Electric Power Plant, MD70.
- 2.2 To start locally select local on the Engine Control Panel.
- 2.3 Start the Lubricating oil priming pump manually.
- 2.4 Press Start.
- 2.5 When engine is running, stop Lubricating oil priming pump and set to AUTO.
- 2.6 The generator can now be connected to the main bus using the Synchrscope panel, MD142, or Electric Power Plant panel, MD70.
- 2.7 To use the POWER CHIEF the generator must be switched to Remote.



---

**Stopping**

- 3.1 The generator can be stopped when in AUTO from the POWER CHIEF panel or the Electric Power Plant panel.
- 3.2 To stop locally, firstly ensure that generator breaker is open.
- 3.3 With the Engine Control in Local, press STOP.
- 3.4 If the generator is to be stopped for maintenance, leave control in Local and close starting air valve.
- 3.5 Placing the electric lubricating oil pump in manual prevents start from remote positions.

<This page is intentionally left blank>

00:04:57 Running Picture MD 142 **Main Switchboard - Synchronising** Alarms Silence ? 

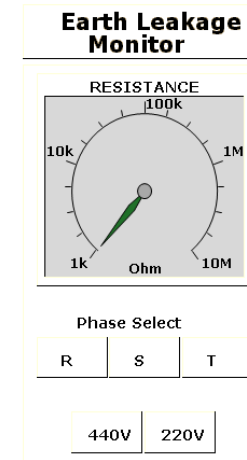
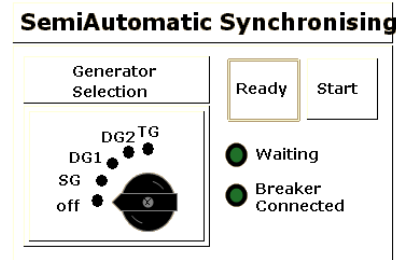
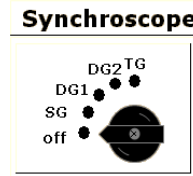
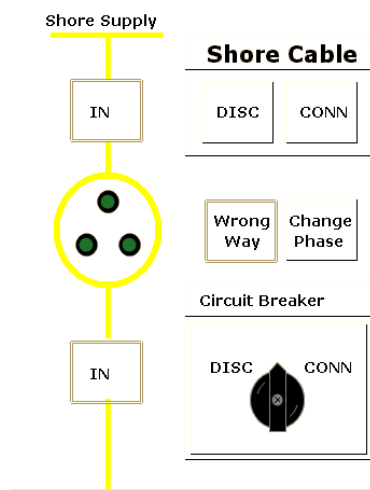
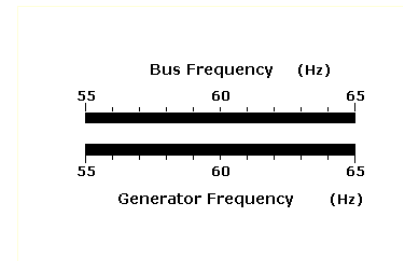
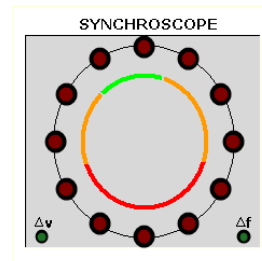
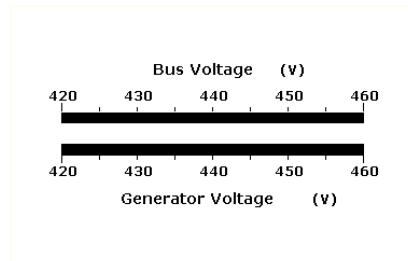

070 101

ERS - MC90-V 2.2.9999.0353 (00)

Unit Conversion Message Log Process Directory Panel Directory Process Overview Back Forward

## 2.3 Synchroscope MD142

### General

The synchroscope panel is used for manual connection of the generators to the bus bar.

The panel consists of selector switches for each generator and indicates the voltage and frequency of the bus and of the selected generator. A synchroscope indicates the phase relationship between main bus and selected generator. There is also an indicator to show that the selected generator is connected to the main bus.

The shore supply can be accessed from this panel.

The synchroscope can be accessed from the individual generator sections of the main switchboard panels. (MD140 -144)

### 1. Connection

- 1.1 The incoming generator must be running and not in AUTO on MD101.
- 1.2 Select incoming generator, voltage and frequency can be compared with bus.
- 1.3 Adjust excitation if necessary to give equal voltages.
- 1.4 Adjust governor control so that incoming generator is slightly faster than bus frequency.
- 1.5 Synchroscope indicator should be turning slowly in a clockwise direction.

- 1.6 Connect breaker when the top synchroscope indicator is lit. The breaker connected light will show that the generator is now connected to the bus.
- 1.7 Increase the governor speed to give the incoming generator some load.
- 1.8 To manually share the load equally use the governor controls on MD70 or on each generator page MD140/141/143/144.

### 2. Disconnection

- 2.1 Ensure generator to be disconnected is not in AUTO on MD101
- 2.2 Use governor controls on MD70 or on each generator to reduce the load on outgoing generator to zero.
- 2.3 Select outgoing generator.
- 2.4 Disconnect, breaker connected light goes out.

### 3. Shore Supply

- 3.1 To connect the shore supply the main bus must be dead
- 3.2 Connect the shore supply cable
- 3.3 Ensure phase rotation is correct
- 3.4 Close circuit breaker
- 3.5 The shore supply must be disconnected before resupplying the main bus from the ships' generators

00:02:58  
Running

Picture MD 77

Shaft Generator

Alarms

Silence

?

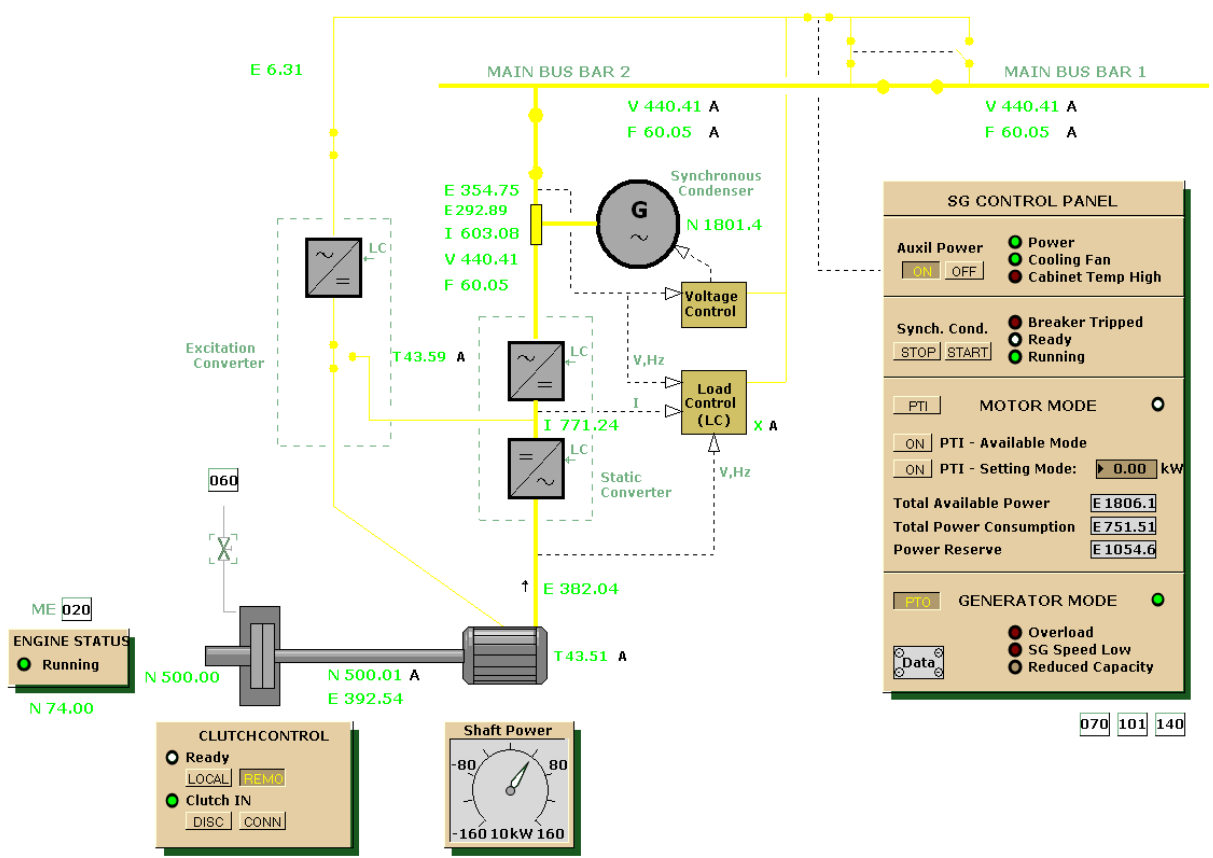
**SG CONTROL PANEL**

**Auxil Power**

- Power
- Cooling Fan
- Cabinet Temp High

**ON** **OFF**

**Synch. Cond.**

- Breaker Tripped
- Ready
- Running

**STOP** **START**

**PTI** **MOTOR MODE**

PTI - Available Mode

PTI - Setting Mode: 0.00 kW

Total Available Power E 1806.1

Total Power Consumption E 751.51

Power Reserve E 1054.6

**PTO** **GENERATOR MODE**

- Overload
- SG Speed Low
- Reduced Capacity

**Data**

070 101 140

ME 020  
ENGINE STATUS  
 Running  
N 74.00

CLUTCH CONTROL  
 Ready  
LOCAL **REMOTE**  
 Clutch IN  
DISC **CONN**

Shaft Power  
-80 80  
-160 10kW 160

ERS - MC90-V 2.2.9999.0353 (00)

Unit Conversion

Message Log

Process Directory

Panel Directory

Process Overview

Back

Forward



## 2.4 Shaft Generator/Motor MD77

### General

The shaft generator/motor system consists of the following main components:

- Control system
- Static converter
- Shaft generator/motor
- Synchronous condenser
- Smoothing reactor

The power from the shaft of the main engine drives the shaft generator via a gear and a clutch. The clutch is driven by control air and will not operate if the control air is missing. The clutch will not engage if the inlet shaft speed is above 300rpm.

The Shaft Generator can supply the ship's network with electrical energy when SG is running above 200rpm. Between 200 and 400rpm the load is limited to half, above 400rpm maximum power is available.

The synchronous condenser controls voltage and frequency. Frequency is determined by condenser speed, voltage by a standard AVC.

A load controller controls power flow through the static converter by timing rectifying thyristors, it also controls the excitation of the shaft generator.

The shaft generator is designed for continuous parallel operation with conventional auxiliary generators and exhaust gas turbo-generator sets.

The control panel supplies auxiliary power for the excitation converter and cooling fan. The SG cannot operate if auxiliary power is lost. The synchronous condenser is started from the control cabinet. When starting the SC considerable power is drawn from the main distribution supply.

The shaft generator can be used as a motor in Power Take In mode. This enables excess available electrical power to be used to supplement the main engine to give greater shaft output. In PTI mode the motor can either use the available electrical capacity or the maximum consumption can be manually selected. The maximum load on the motor will always leave a reserve of 300kW.

### Operation Procedure

Normal operation involves engaging the clutch at stand-by in order that the generator may be used on passage.

During manoeuvring electrical power is supplied from the diesel generators.

When the vessel is on passage the turbine generator is used in parallel with the shaft generator.



If there is available electrical capacity from the turbine generator then the shaft generator may be used in PTI mode to increase efficiency.

In case of main engine reduced power or if extra shaft power is required the shaft generator can be used in PTI mode with the diesel generators.

### 1. Starting shaft generator

- 1.1 Ensure auxiliary power on and cooling fan is running.
- 1.2 Check that enough reserve power is available to start synchronous condenser, about 150kW.
- 1.3 Start synchronous condenser.
- 1.4 Open air valve to clutch.
- 1.5 Ensure input shaft speed below 300 rpm and connect clutch in local control. When clutch has engaged change to remote control.

### 2. Generator Mode

- 2.1 Normal mode is generator mode as indicated on the control panel.
- 2.2 The generator can be connected manually or automatically from the Power Chief panel in the normal manner.

### 3. Power Take In

- 3.1 To use PTI the generator breaker must first be connected in the normal manner.
- 3.2 PTI can be selected locally or from the Power Chief panel.
- 3.3 In PTI mode select either Available Mode to use all available power (300kW will be in reserve) or select Setting Mode where the motor power can be set up to a maximum of 300Kw in reserve.

- 3.4 To change to PTI select Generator Mode.

### 4. Stopping

- 4.1 It is normal to leave the clutch engaged when main engine is running otherwise, in order to engage clutch, the engine would have to be slowed down.
- 4.2 If the generator is not required, disconnect circuit breaker in the normal manner.
- 4.3 The synchronous generator may now be stopped.
- 4.4 If maintenance is to be carried out it will be necessary to turn off the auxiliary power, disengage the clutch and close the air valve to the clutch.



<This page is intentionally left blank>

00:02:38  
Running

Picture MD 71

Main Switchboard - Starters

Alarms  
Silence

Earth Leakage  
I 0.00 A

Resistance  
10k 100k 1M  
1k Ohm 10M

Phase Select  
R S T

440V 220V

Thrustor/Deck  
400 600  
200 800  
0 1000 kW  
E 6.31

Eng. Room Ventilation

IN	ER Air Sup Fan 1	E7.74
IN	ER Air Sup Fan 2 *	E7.94
IN	ER Air Sup Fan 3	E4.91
IN	ER Air Sup Fan 4	E4.99

IN	FO Circ. Pump 1	E5.17
IN	FO Circ. Pump 2	E0.00
IN	FO Supply Pump 1	E4.84
IN	FO Supply Pump 2	E0.00
IN	Main LO Pump 1	E75.86
IN	Main LO Pump 2	E0.00
IN	CamShaft LO Pump1	E10.70
IN	CamShaft LO Pump2	E0.00
IN	Spare	E0.00
IN	Spare	E0.00

IN	ER Air Exh Fan 1	E0.00
IN	ER Air Exh Fan 2 *	E0.00
IN	ER Air Exh Fan 3	E4.85
IN	ER Air Exh Fan 4	E0.00

IN	Main SW Pump 1	E0.00
IN	Main SW Pump 2	E115.15
IN	Main LTFW Pump 1	E80.46
IN	Main LTFW Pump 2	E0.00
IN	Main HTFW Pump 1	E17.24
IN	Main HTFW Pump 2	E0.00
IN	Stern T. LO Pump 1	E4.11
IN	Stern T. LO Pump 2	E0.00
IN	Spare	E0.00
IN	Spare	E0.00

073 Display kW Amp

From ESWB

CBR Doc: V

Starters  
400 600  
200 800  
0 1000 kW  
E 359.47

070 V 440.53 A

E 6.31  
E 6.31  
I 11.69  
Z 0.71

I 0.00 A

Section A1	I 195.36	E 114.20	V
	Z 0.77	E 95.80	
	I 0.00	E 0.00	
	Z 0.00	E 0.00	

Section B1	I 378.82	E 221.81	V
	Z 0.77	E 185.31	
	I 34.73	E 23.47	
	Z 0.89	E 12.32	

Section A2	V
------------	---

Section B2	V
------------	---

V 440.53 A

072

M M M

IN	Start Air Compr. 1	E0.00
IN	Start Air Compr. 2	E0.00
IN	Service Air Compr.	E0.00
IN	Main Fire Pump 1	E0.00
IN	Main Fire Pump 2	E0.00
IN	Spare	E0.00
IN	Spare	E0.00
IN	FO Transfer Pump 1	E0.00
IN	FO Transfer Pump 2	E0.00

IN	Exh. B. Circ. P. 1	E7.49
IN	Exh. B. Circ. P. 2	E0.00
IN	Blr Comb. Air Fan	E0.00
IN	Boiler HFO Pump	E7.23
IN	Boiler DO Pump	E0.00
IN	Main Feedw Pump	E8.74
IN	Auxil Feedw Pump	E0.00
IN	Spare	E0.00
IN	Spare	E0.00

IN	Bow Thruster	E0.00
IN	Deck Machinery	E0.00

V 070

ERS - MC90-V 2.2.9999.0353 (00)

Unit Conversion

Message Log

Process Directory

Panel Directory

Process Overview

Back

Forward

## 2.5 Main Switchboard-Starter section MD71

### General

The starters are grouped into four main sections. Deck machinery and bow thruster are supplied via a bus tie.

Each starter group has indication for current, active power, reactive power and power factor. Starters indicated with an asterix are supplied from elsewhere and are not included in the calculations for the starter group.

The breakers are operated by pressing the IN button. Pressing IN again will open the breaker. The green indicator shows if the machinery is running.

The display value of the breakers may be changed from active power to current.

Total Earth Leakage current is constantly monitored. Earth fault finding is available by selecting 440v or 220v distribution system and switching between phases.

In case of overload of available supply the breakers can be grouped for non essentials to automatically disconnect. Non essentials must be circuits not required for the safe operation of the vessel.

The starter circuit breakers can be individually grouped by setting the function variable to one of eight settings.

- 1 OL trip only
- 2 OL trip and auto pump restart
- 3 OL trip and zero volts disconnection
- 4 OL trip and zero volts trip
- 11 Non Essential + 1
- 12 Non Essential + 2
- 13 Non Essential + 3
- 14 Non Essential + 4

The settings can be found on the CBR Doc variables.



Non Essentials trip as dictated by the settings on the generator breakers on MD70.

00:02:41  
Running

Picture MD 72

Main Switchboard - Feeders

Alarms  
Silence

Display

CBR Doc:

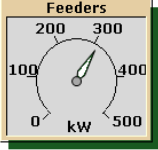

E 310.47

<input type="checkbox"/> IN	Steering Gear 1	E 23.42
<input type="checkbox"/> IN	Fire Station	E 5.12
<input type="checkbox"/> IN	Emerg. Switchboard	E 70.35
<input type="checkbox"/> IN	Main Transformer	E 38.68
<input type="checkbox"/> IN	Air Cond. Plant	E 36.23
<input type="checkbox"/> IN	Refrigeration Plant	E 40.29
<input type="checkbox"/> IN	Incineration Plant	E 0.00
<input type="checkbox"/> IN	Distiller Plant	E 9.65
<input type="checkbox"/> IN	Spare	E 0.00
<input type="checkbox"/> IN	Inert Gas Plant	E 0.00
<input type="checkbox"/> IN	Sanitary and FW	E 0.00
<input type="checkbox"/> IN	Cathodic Protect. S.	E 7.74
<input type="checkbox"/> IN	Marine Growth Prot.	E 11.90
<input type="checkbox"/> IN	Sewage Treatment Pl.	E 5.55

<input type="checkbox"/> IN	ME Auxil Blower	<input type="checkbox"/> IN	E 0.00
<input type="checkbox"/> IN	ME Turning Gear	<input type="checkbox"/> IN	E 0.00
<input type="checkbox"/> IN	HFO Purif. Sys.	<input type="checkbox"/> IN	E 12.59
<input type="checkbox"/> IN	LO Purifier System	<input type="checkbox"/> IN	E 7.14
<input type="checkbox"/> IN	DO Purifier System	<input type="checkbox"/> IN	E 5.91
<input type="checkbox"/> IN	Cond. Vacuum Pumps	<input type="checkbox"/> IN	E 3.72
<input type="checkbox"/> IN	Main Condensate Pump	<input type="checkbox"/> IN	E 3.10
<input type="checkbox"/> IN	Aux. Condensate Pump	<input type="checkbox"/> IN	E 0.00
<input type="checkbox"/> IN	LO Make-up Pumps	<input type="checkbox"/> IN	E 0.00
<input type="checkbox"/> IN	FW Make-up Pumps	<input type="checkbox"/> IN	E 0.00
<input type="checkbox"/> IN	Spare	<input type="checkbox"/> IN	E 0.00
<input type="checkbox"/> IN	Cargo/Ballast System	<input type="checkbox"/> IN	E 0.00
<input type="checkbox"/> IN	Accomm. Heating	<input type="checkbox"/> IN	E 17.17
<input type="checkbox"/> IN	Accomm. Cooking	<input type="checkbox"/> IN	E 11.92

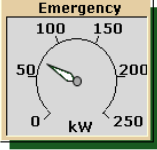

E 70.35

V 440.43 A      A1    I 383.74    E 248.93    V      B1    I 87.73    E 61.54    V

Z 0.85    E 153.89      Z 0.92    E 26.16

I 70.91    E 38.68

Z 0.72    E 37.81

● Ready  
 IN    OUT

T 48.90 A

V 224.14 A

Main 220 V Bus    I 79.71    E 24.58    I 41.15    E 12.30

Z 0.79    E 18.80      Z 0.77    E 10.20

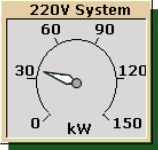

E 36.88

<input type="checkbox"/> IN	Light Panel - Bridge	E 4.27
<input type="checkbox"/> IN	Light Panel - E.Room	E 3.21
<input type="checkbox"/> IN	Light Panel - Deck	E 3.70
<input type="checkbox"/> IN	Light Panel - Accomm	E 5.61
<input type="checkbox"/> IN	Contr. Cons - ECR	E 2.90
<input type="checkbox"/> IN	Contr. Cons - Boiler	E 2.50
<input type="checkbox"/> IN	Contr. Cons - Cargo	E 2.38

<input type="checkbox"/> IN	Minor Panel - Bridge	E 2.39
<input type="checkbox"/> IN	Minor Panel - E.Room	E 1.25
<input type="checkbox"/> IN	Minor Panel - Deck	E 1.60
<input type="checkbox"/> IN	Minor Panel - Accomm	E 3.11
<input type="checkbox"/> IN	Misc Control Panel 1	E 1.35
<input type="checkbox"/> IN	Misc Control Panel 2	E 1.35
<input type="checkbox"/> IN	Misc Control Panel 3	E 1.24

Light Relay 1

M   M      A2      V      B2      V      V    D70

ERS - MC90-V 2.2.9999.0353 (00)

Unit Conversion

Message Log

Process Directory

Panel Directory

Process Overview

Back

Forward

## 2.6 Main Switchboard-Feeder section MD72

### General

The feeders are grouped into four main sections. The 220v sections are fed from the main bus via a circuit breaker and transformer.

Each feeder group has indication for current, active power, reactive power and power factor. Feeders indicated with an asterisk supply elsewhere and are not included in the calculations for the feeder group.

The breakers are operated by pressing the IN button. Pressing IN again will open the breaker.

The display value of the breakers may be changed from active power to current.

In case of overload of available supply the breakers can be grouped for non essentials to automatically disconnect. Non essentials must be circuits not required for the safe operation of the vessel.

The feeder circuit breakers can be individually grouped by setting the function variable to one of eight settings.

- 1 OL trip only
- 2 OL trip and auto pump restart
- 3 OL trip and zero volts disconnection
- 4 OL trip and zero volts trip
- 11 Non Essential + 1
- 12 Non Essential + 2
- 13 Non Essential + 3
- 14 Non Essential + 4

The settings can be found on the CBR Doc variables.

Non Essentials trip as dictated by the settings on the generator breakers on MD70.

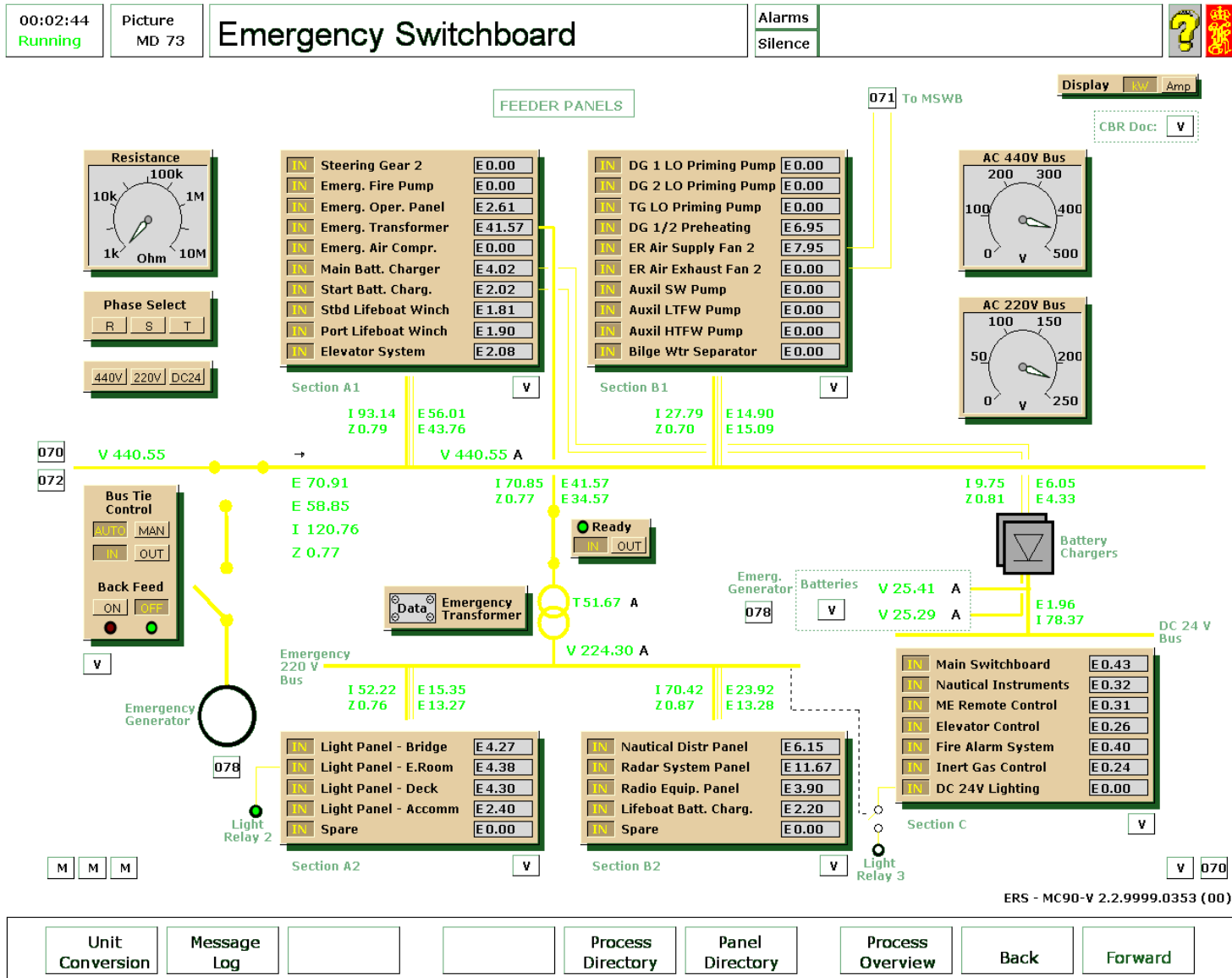



## 2.7 Emergency Switchboard MD73

### General

The emergency switchboard supplies circuits necessary for the safety of the vessel. These include communications, navigation lights, fire alarm, fire and flood control.

The feeders are grouped into four main sections. Two 440v sections and two 220v sections supplied via a circuit breaker and transformer.

Each feeder group has indication for current, active power, reactive power and power factor. Feeders indicated with an asterix supply elsewhere and are not included in the calculations of the feeder group.

The breakers are operated by pressing the IN button. Pressing IN again will open the breaker.

The display value of the breakers may be changed from active power to current.

Earth fault finding is available by selecting 440v, 220v or 24v dc distribution system and switching the resistance meter between phases.

The feeder circuit breakers can be individually grouped by setting the function variable to one of eight settings.

- 1 OL trip only
- 2 OL trip and auto pump restart

- 3 OL trip and zero volts disconnection
- 4 OL trip and zero volts trip

The settings can be found on the CBR Doc variables. The emergency switchboard supplies are all essential and should not be connected to non-essential trips.

The emergency batteries are supplied by battery chargers via the 440v emergency bus. There are two sets of batteries, one for starting the emergency generator and one for the main 24v supply. Terminal voltage of each battery is displayed.

### 2.7.1 Emergency Generator Back Feed Mode

The Emergency Switch Board (ESWB) and the Main Switch Board (MSWB) can be connected in two different ways.

#### Normal Mode

The Emergency Switch Board is connected to the Main Switch Board by a selection switch. If there is voltage on the Main Switch Board the position is kept in "MSWB". When the switch is deactivated by loss of main voltage or by emergency generator "test 2" override, the switch takes default position, "Emergency Generator". The selection switch functions as a safe guard against overloading the Emergency Generator by mechanically isolating it from the main bus.

### **Optional Mode**

If it is required that the Emergency Generator in critical situations also should be able to feed the main bus system, the selection switch must be exchanged with a bus-tie breaker with associated bus-tie control logics. In addition the Emergency Generator must be permanently wired for connection to the emergency bus bar.

Changing from Normal to Optional Mode is done by setting the parameter C06136, on variables page 7005, to 1. The Optional Mode is denoted “Back Feed Permit (USCG spec) Mode”

### **Operation procedure**

In “Normal Mode” the bus-tie control is always fixed to “Auto” and no manual override is accepted. The bus-tie control is then simply representing the automatic positioning of the selector switch by main bus voltage

In “Optional Mode” the bus-tie control logics function as follows:

#### **Auto**

At loss of main voltage the bus-tie breaker opens. At return of voltage the emergency bus is de-energized, by disconnection of the EG if connected, before the bus-tie breaker is reconnected to the main bus. Activation of EG-test2 will “simulate” loss of main voltage and make the bus-tie breaker disconnect.

#### **Manual**

The main bus and the emergency bus can be split manually without any restrictions by disconnecting the bus-tie breaker (“Out” command). Note that the EG stand by control (see MD70) requires

the bus-tie control to be in “Auto”, transferring bus-tie control to manual also disables automatic EG operation.

Even in “Manual” mode the bus-tie breaker is automatically disconnected if loss of main bus power.

If there is voltage on the emergency bus, the connect (“In”) command will not function, unless the “Back-Feed” override is ‘On’.

#### **Back-Feed**

Selection of bus-tie “Back-Feed” mode is protected by a key lock etc, indicated by a red light when activated.

The bus-tie control will be fixed to “Manual” and the connect-inhibit, which is normally active in “Manual”, is also disabled, leaving the bus-tie to direct operator control.

Connection of the bus-tie should never be attempted when there is voltage on both the main and the emergency switch board.

Note: When then the Emergency Generator is connected to the Main Switch Board by Back-Feed it is easily overloaded. All automatic start-up of equipment must be disabled before supplying voltage to the main bus!

### 3 MAIN ENGINE AND MAIN ENGINE SYSTEMS

#### 3.1 Main Engine

The propulsion machinery is based on one MAN B&W 5L90MC, low speed, 5 cylinder configuration, 2-stroke, turbocharged, reversible diesel engine. The main engine is coupled to a propeller shaft with both fixed pitch propeller and controllable pitch propeller (selectable by the instructor). Also a shaft generator is attached to the main engine.

**Main engine data:**

- Cyl Bore 900 mm
- Piston Stroke 2916 mm
- Number of Cylinders 5
- Number of Air Coolers 2
- Number of Turbo Chargers 2
- Continuous Service Rating ME 18 MW
- Corresponding Engine Speed 74 rpm
- Mean Indicated Pressure 16.9 Bar
- Scavenge Air Pressure 2.1 Bar
- Turbine Speed 7600 rpm
- Number of Prop. Blades 5
- Propeller Pitch 0.9 P/D
- Specific Fuel Oil Consumption 168 g/kwh



### Model particulars

The main engine model ("cylinder model") is a comprehensive, semi-empirical software program module where the result of the combustion process is calculated. Important variables are:

- Mean indicated cylinder pressures
- Mean effective cylinder pressures
- Total shaft torque
- Exhaust temperatures
- Total heat to liners (FW)
- Total heat to pistons (FW)
- Total heat to bearings (LO)

The result is dependent on several variables and the most influential ones are:

- Engine speed
- Injected amount of fuel
- Fuel heat value/viscosity
- Scavenging air pressure
- Lubricating oil inlet flow/temperature
- Jacket water inlet flow/temperature
- Mean liner metal temperature

The overall shaft torque is computed from the mean cylinder pressures. The torque balance differential equation between the propeller (water) torque and the shaft (engine) torque is then solved by integration to give the engine speed.

If the cooling water flow is reduced or cooling water pumps are stopped, the cooling effect of the fresh water is drastically reduced and the liner/exhaust temperatures will be very high. If the engine is operated without lubrication, the mechanical friction increases the piston and bearing temperatures will increase. Eventually piston seizure and bearings damage will occur. Long operation at extreme high exhaust temperatures will cause damage to the exhaust valves.

Stop of the main engine caused by physical damage on the engine is indicated by "ME damage", and may result from:

- Exhaust valve breakdown
- Piston breakdown
- Cylinder liner breakdown
- Bearing breakdown
- Fire damage

<This page is intentionally left blank>

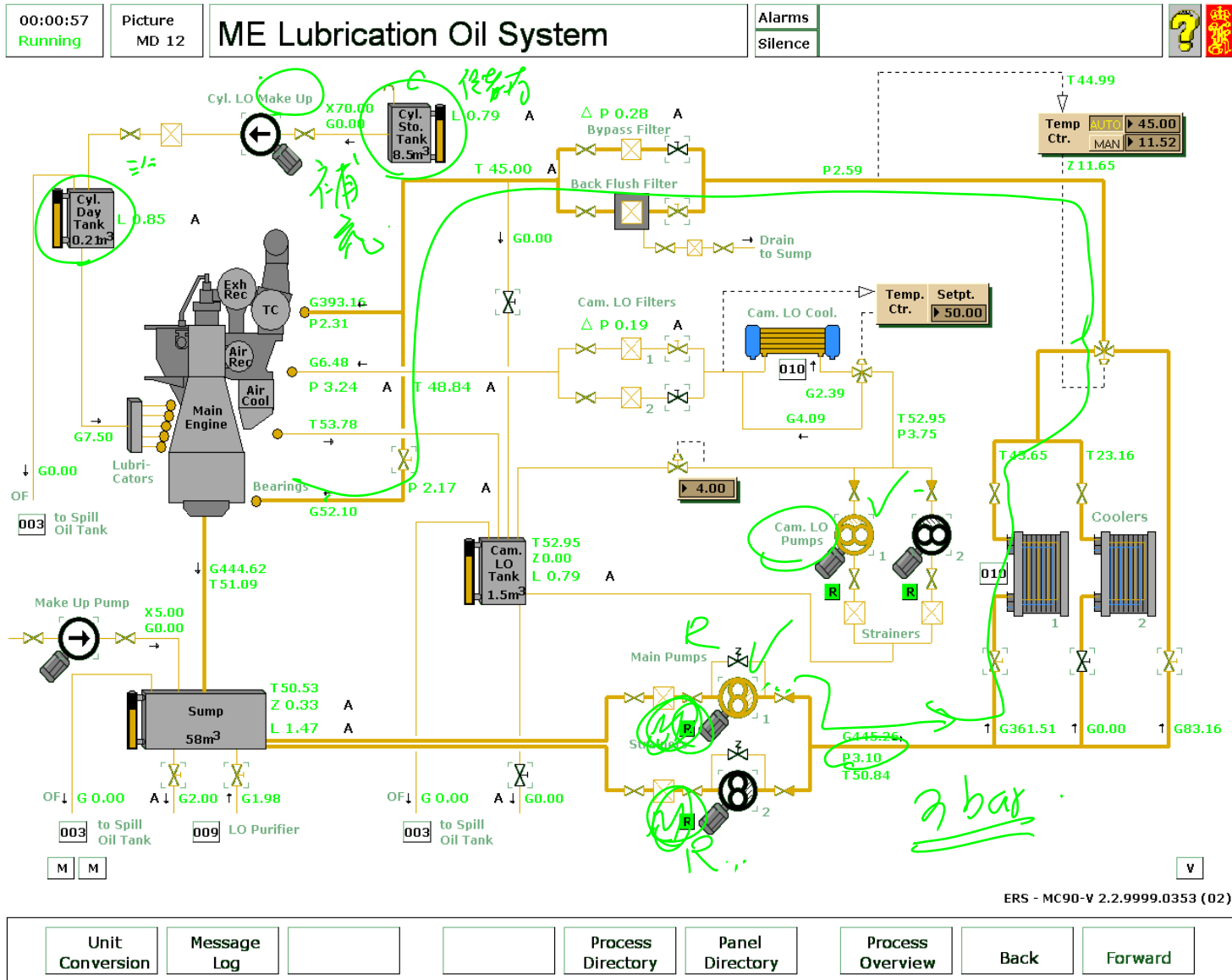

## **3.2 ME Lubrication Oil System MD12**

### **General**

The lubrication oil from the main engine sump is collected in a sump tank below the engine.

The LO pumps are protected by a pressure relief valve which opens when the pressure rises over a preset value. These valves are not modelled in detail and are not available from the variable list.

The service tank oil can also be circulated by the LO purifier.

New oil is supplied by a make-up pump with flow directly to the sump tank.

The lubrication oil is cooled in two LT fresh water cooled LO coolers and is then passed through an automatic backflush filter or a standby conventional filter before it enters the main engine. The LO temperature is controlled by a PI controller, which regulates a by-pass valve for the LO coolers.

The LO filters must be checked regularly to avoid pressure/flow reduction.

The sump tank oil level will gradually decrease due to oil consumption and possible drain/sludge discharge from the purifier.

The level is unstable in poor weather and if the level is low, there may be false alarms/shut downs.

If the purifier is operated with “broken” water seal, oil is continuously discharged to the sludge tank and there is a risk of emptying the LO sump tank completely. The oil pressure after the pumps will be reduced towards zero as the LO sump tank runs dry.

The oil temperature in the sump tank is affected by the return oil flow/temperature from the main engine, the oil flow/temperature from the purifier and the heat loss to the surroundings. If all inlet flows stop, the temperature will gradually approach ambient air temperature. Low oil temperature gives reduced flow at main engine.

### **Cylinder Lubrication**

A simple cylinder lubrication model is included. The day tank is refilled by pump from the storage tank. There will be a steady consumption of cylinder oil, dependent on main engine speed.

The cylinder LO tank must be refilled periodically. At low cylinder LO tank level there will be ME slow down/shut down.

### **Cam Lubrication**

The lubrication oil from the main engine cam shaft is collected in a cam shaft LO tank.

The LO pressure is controlled after the two cam LO pumps by a pressure control valve with return flow to the cam LO tank.

Cam LO tank make-up is taken from the LO inlet main engine line. Discharge of the tank is directly to the spill oil tank.

The cam lubrication oil is cooled by a LT fresh water cooled LO cooler and is then passing a double filter before it enters the main engine. The LO temperature is controlled by a P controller, which regulates a by-pass valve for the cam LO cooler.

The LO filters must be cleaned regularly to avoid pressure/flow reduction.

### Operation procedures

#### Start up for main engine

Ensure main engine sump has sufficient oil.  
Set temperature controller to AUTO and 45°C  
Ensure suction and delivery valves on both main lube oil pumps are open  
Ensure one cooler has inlet and outlet valves open  
Ensure inlet and outlet valves to back flush filter are open  
Ensure main bearing supply valve is open.  
Start one of the main lube oil pumps in manual wait until the lube oil pressure has risen to about 3 bar then in pump/compressor Autochief page, set pump control to auto.  
It should only be necessary for one pump to be running with the other in standby.  
Ensure oil is flowing to piston cooling and main bearings at correct temp.

#### Start up of cam shaft system

Set temp. control to 50°C  
Ensure Cam lube oil tank level is more than 0.3m  
Set cam lube oil pressure to 4 bar.  
Check one filter in use and suction and delivery valves on both pumps open.  
One pump started manually then switched to AUTO when pressure reaches about 3.7 bar.

#### Start up for cylinder LO system

Ensure day tank level is more than 0.3m.  
Check all relevant valves are open  
The flow will vary with engine speed.

#### System shut down

When engine has stopped at Finished with Engines wait for approx 30 mins to ensure engine has cooled down and stop all lube oil pumps. Sump temperature in port is normally maintained by continually running the lube oil purifier.

③ → manual 手动  
AUTO



<This page is intentionally left blank>

00:01:38 Running Picture MD 29 **ME Bearing System** Alarms Silence ? 

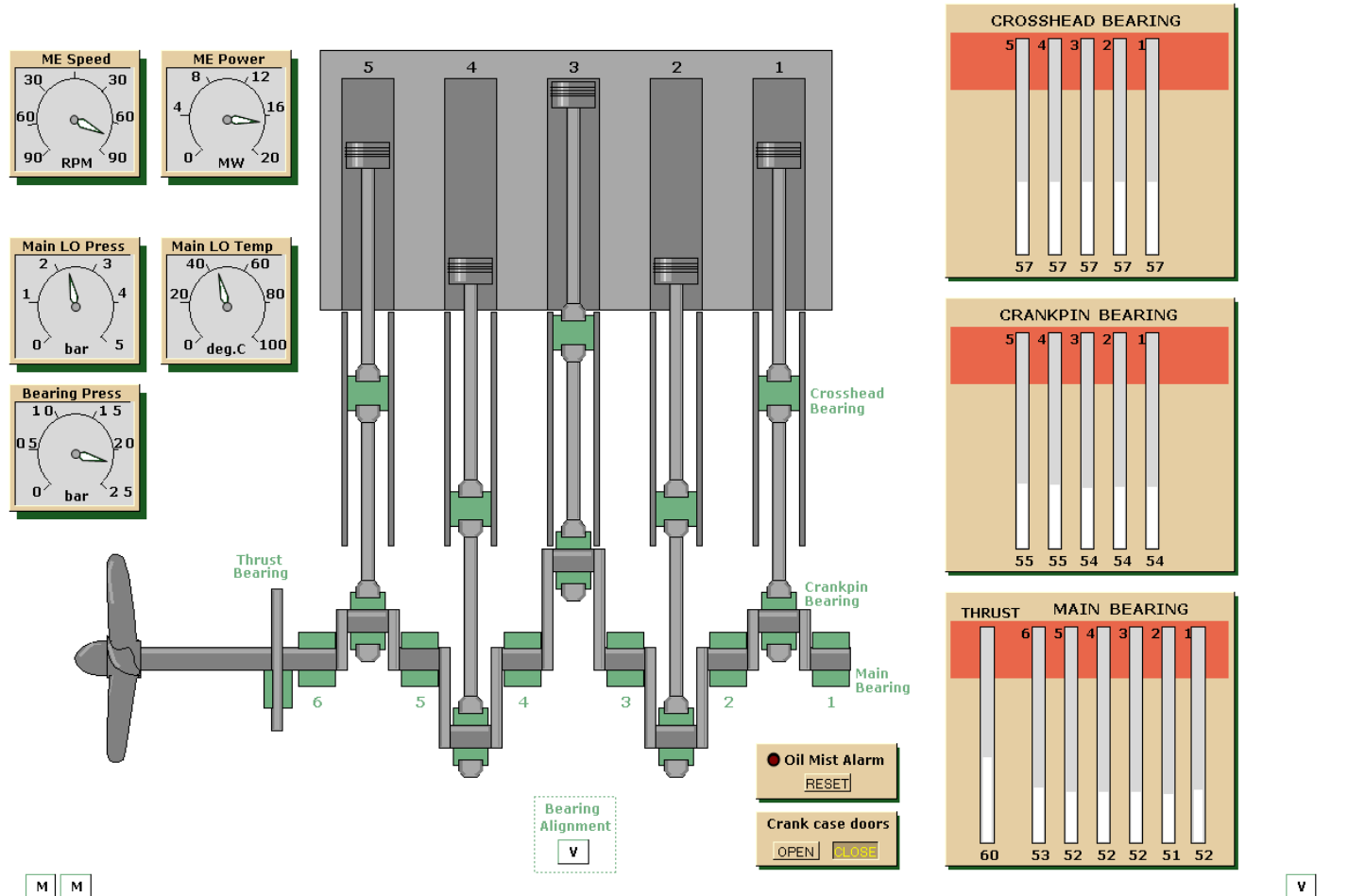

ERS - MC90-V 2.2.9999.0353 (01)

Unit Conversion Message Log Process Directory Panel Directory Process Overview Back Forward

### 3.3 ME Bearings MD29

#### General

The screen provides the operator with a clear display of all bearing temperatures within the engine, as well as the main parameters that affect bearing load, such as main engine speed, engine power, and the lubricating oil supply.

The bearing temperature depends on the cylinder power, the lubricating oil flow and temperature, and ambient temperature.

The shaft friction includes static friction as well as speed-dependent friction.

Comparisons between the various bearings can be easily made, and should a bearing temperature increase above 80°C, then the indicating bar will change to red to aid identification. At the same time the bearing concerned will also change colour to red.

The screen will also display the presence of oil mist within the crankcase, as well as which units are affected. Should oil mist be detected, then the engine protection system will activate, and an engine slow down will occur.

The MAN B&W procedures for reaction to an oil mist alarm, or other alarms that could lead to the oil mist situation are:

1. Reduce engine power/pitch down to slow-down level, if this is not an automatic function. This will drastically reduce the load on the engine bearings, and hence the production of oil mist.
2. Contact bridge, and ask to STOP engine. If the vessel is in a confined area, it may not be possible to stop the vessel. Hence the engine would continue on **minimal power**.
3. When stop order is received, stop the engine and close the fuel supply to the engine by stopping the booster pumps. This will **reduce** the oil mist in the crankcase as the engine cools.
4. Switch off the auxiliary blowers.
5. Open engine room casing. This will reduce the pressure rise in the engine room, should the crankcase relief devices operate
6. Personnel to vacate engine room. This is for the personnel safety of the engine room staff should flames issue from the relief valves. It may be prudent to have a minimal staff in the control room to monitor the situation, and to maintain the main services, but under no circumstances should personnel operate on the exhaust of the engine.
7. Prepare fire fighting equipment. A safety precaution against outbreaks of fire in the engine room, from any flames issuing from the crankcase relief doors.



8. **Do not open the crankcase until after at least 20 minutes.**

You must allow time for the oil mist to cool and fully condense. It is also recommended that the oil mist detector alarm level should reset, which indicates that the oil mist levels are well below the Lower Explosive Limit. Obviously no naked flames should be used on the initial entry.

9. Stop all lube oil pumps. To allow personnel entry into the crankcase.

10. Isolate the starting air, and engage the turning gear.

11. Open the crankcase doors, and inspect the following areas for overheating:

- Main and bottom end bearings
- Thrust bearing
- Crosshead bearings
- Piston rods
- Stuffing boxes
- Chains
- Vibration dampers
- Moment compensators
- Telescopic pipes
- Cracked piston crown, allowing oil mist to enter crankcase via cooling oil return
- Overheated diaphragm, from a scavenge fire

12. Overheating can be identified by

- Melted or squeezed white metal from the bearings
- Discolouration of the crankcase paint in the vicinity

- Burnt or carbonised oil deposits
- Excessive bearing clearances
- Excessive oil flow from a bearing

*Note: Command for open/close crank case doors at MD29 "ME Bearing System".*

*Oil Mist Alarm diode will light as long as mist is detected (reset after vent).*

*When one of the malfunctions (cylinder or crank case mist) is set, it will not be possible to get rid of the mist by resetting the malfunction. The crank case must be ventilated following the correct procedure described in the MC90-V user manual. If mist alarm is ignored (for long time) or doors opened too early a crank case explosion will occur!*

<This page is intentionally left blank>

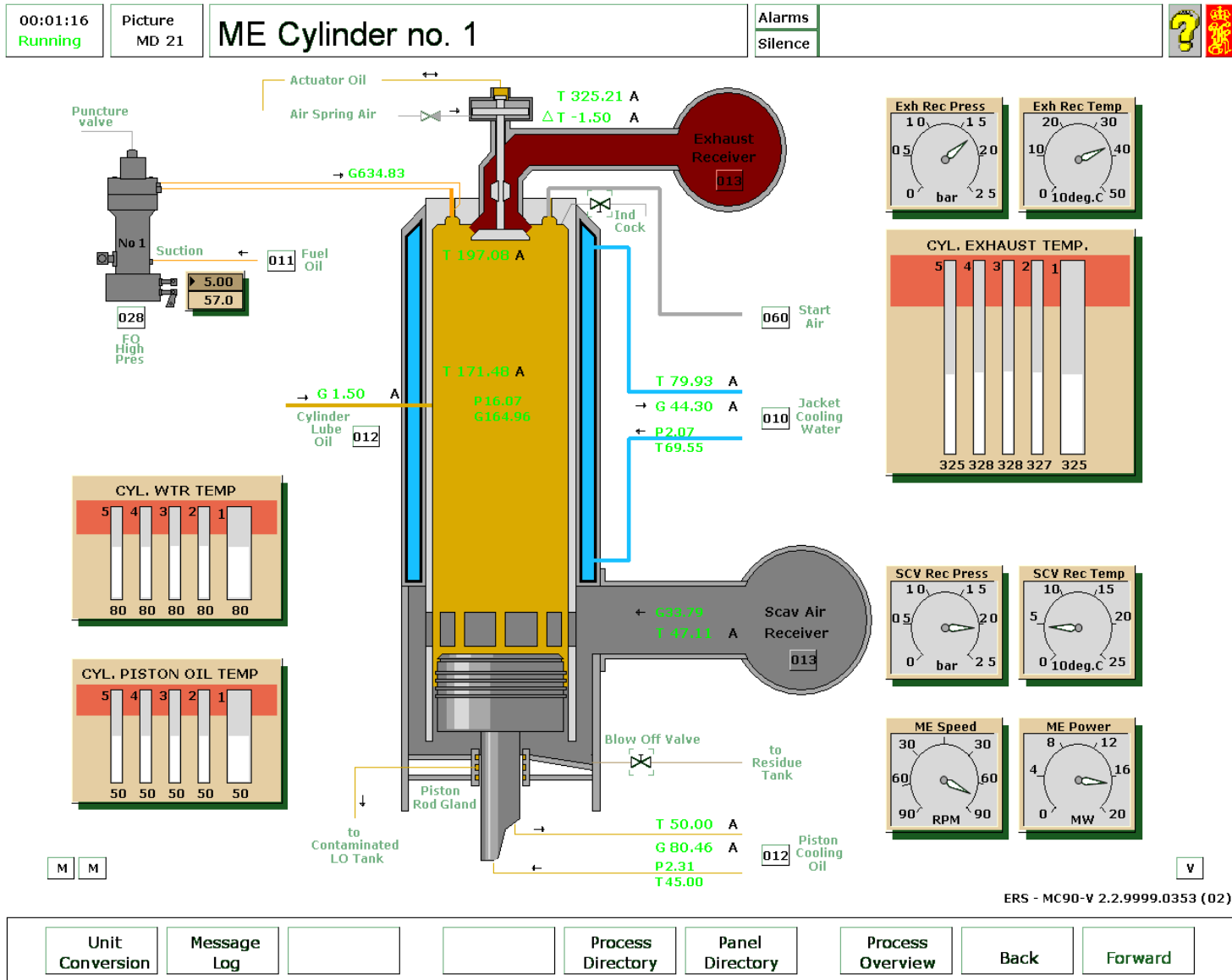

### 3.4 ME Cylinders MD21

#### General

The five screens are indications only of the various parameters present. The following indications are present:

- Cylinder exhaust temperature and deviation from the average exhaust temperature.
- Cylinder water temperature and deviation from the average water temperature.
- Cylinder piston oil temperature and deviation from the average piston oil temperature.
- Exhaust receiver pressure and temperature gauges.
- Scavenge receiver pressure and temperature gauges.
- Piston oil cooling temperature and flow indications
- Main engine speed and power gauges.
- Cylinder oil flow
- Fuel pump rack and VIT setting.

A blow down valve to drain the contents of the scavenge receiver is provided on each cylinder screen. This valve should be opened twice daily.

00:01:31 Running	Picture MD 27	<b>ME Piston Ring Monitor</b>	Alarms	
			Silence	

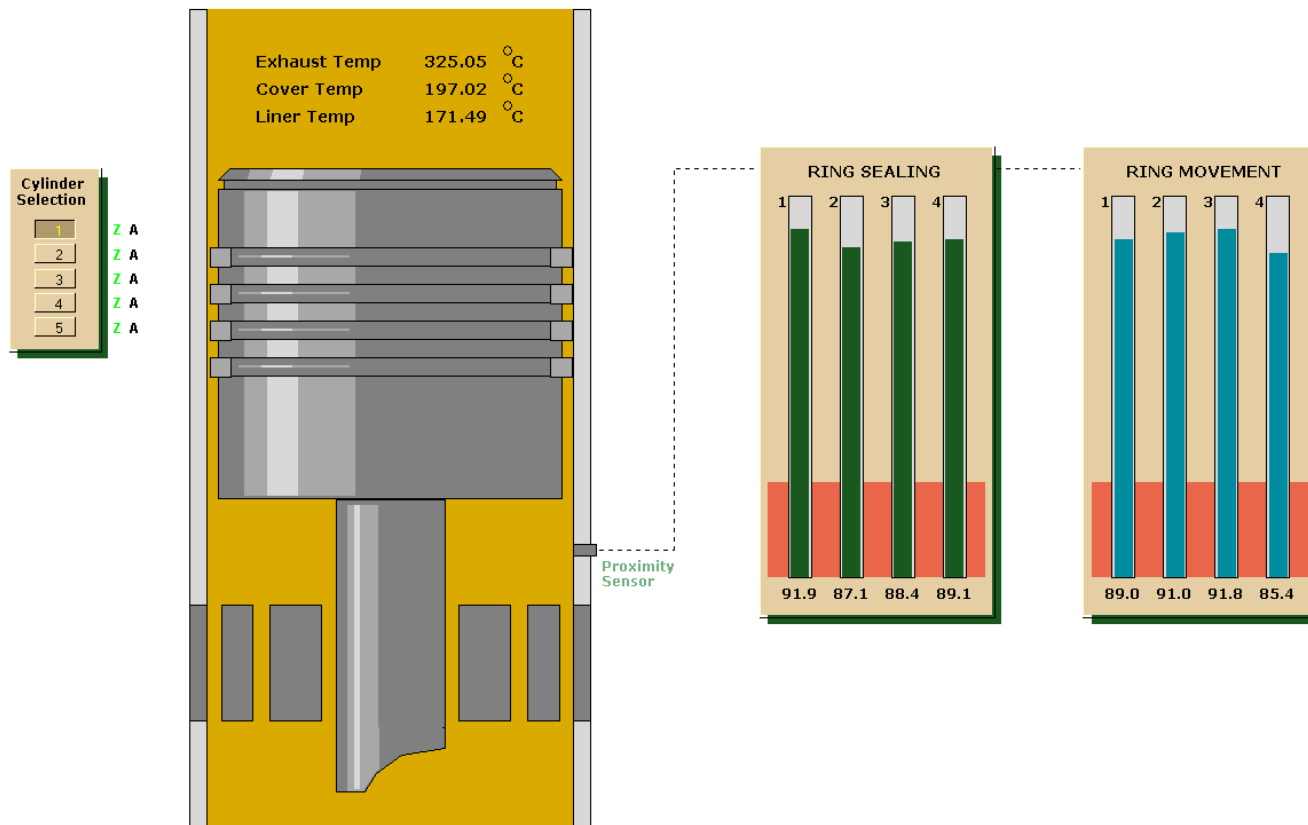

v

ERS - MC90-V 2.2.9999.0353 (00)

Unit Conversion	Message Log			Process Directory	Panel Directory	Process Overview	Back	Forward
-----------------	-------------	--	--	-------------------	-----------------	------------------	------	---------



### 3.5 ME Piston Ring Monitor MD27

#### General

The screen provides an indication of the piston ring condition within each cylinder. Two bar charts are provided for each cylinder. The cylinder can be selected, and provides a display for each piston ring for sealing and movement.

Under normal circumstances the ring sealing and movement will be high. Should the ring wear increase then ring sealing will reduce,

Should the cylinder lubrication be reduced, then the ring movement will reduce.

When the ring sealing and movement reduces below an acceptable level, then an alarm will be activated.

00:00:50 Running	Picture MD 10	<b>Fresh Water System</b>	Alarms	?
			Silence	

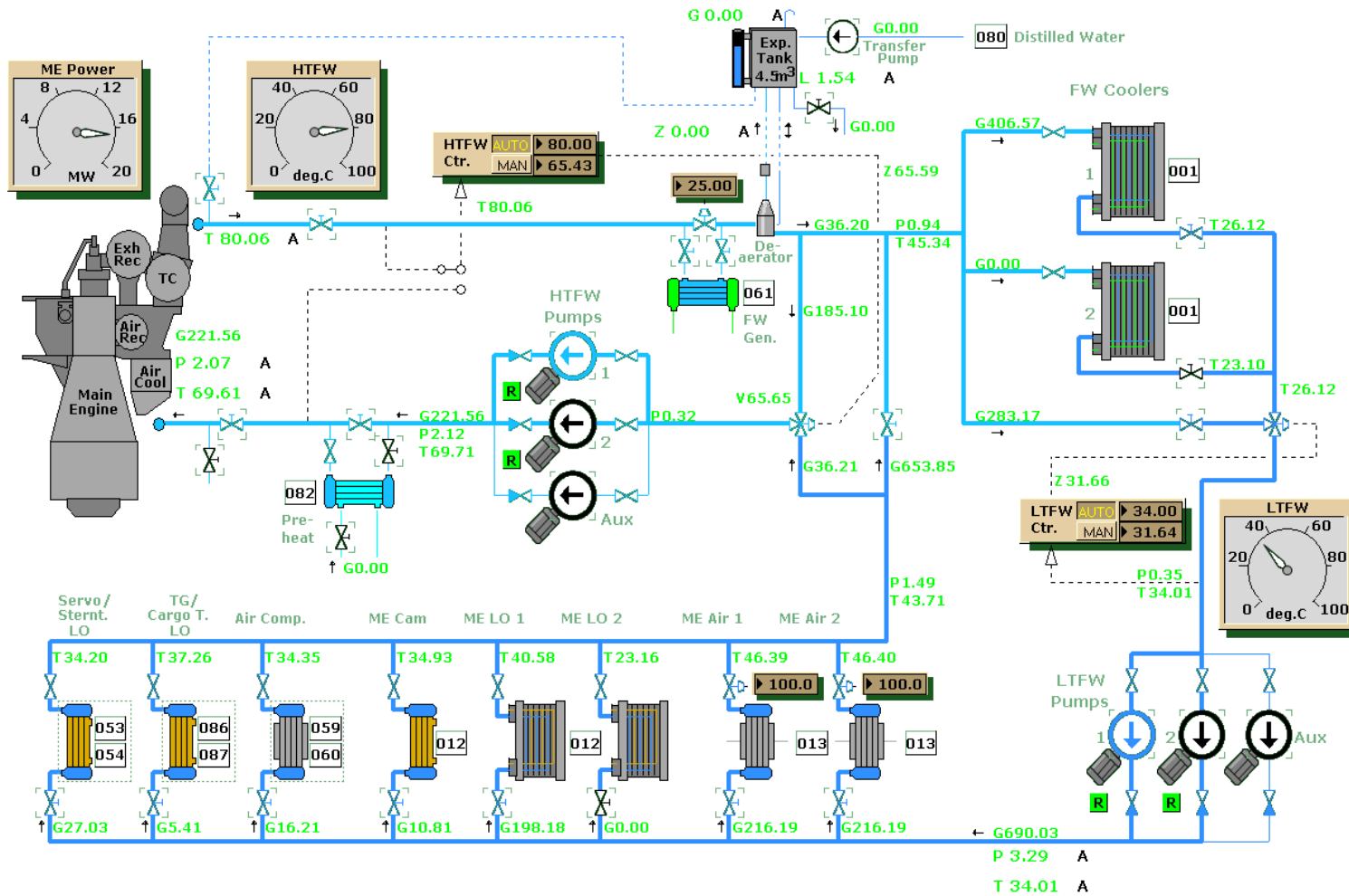

M

V

ERS - MC90-V 2.2.9999.0353 (00)

### 3.6 Fresh Water Cooling System MD10

#### General

The fresh water cooling system is separated in two subsystems:

- Low Temperature System
- High Temperature System

The Low Temperature Fresh Water (LTFW) system cools all auxiliary equipment, such as:

- start-air compressors
- service air compressor
- lub.oil system for turbo-generator and cargo pump turbines
- stern tube and propeller servo oil system
- main engine air cooling system
- cooling of the oil in the camshaft and main engine lub.oil system.

The LTFW pumps (normally only one in operation), pump the fresh water through the above mentioned coolers. The FW system is cooled by the SW system. The effect of cavitation is modelled for the LTFW pumps. The auxiliary LTFW pump is mainly used when in harbour or during blackout.

The fresh water temperature in the LTFW system is controlled by a PID controller, which actuates a three-way mixing valve, placed after the two fresh water coolers. This controller can be operated in manual or auto mode. The controller input signal is given by the temperature before the LTFW pumps.

From the LT/HT junction, some of the LTFW is led directly to the FW coolers, while some is led to the HTFW loop.

The High Temperature fresh water cools the cylinder liners of the main engine. Some of the excessive heat is used for heating the fresh water generator. The fresh water through the main engine is driven by two main and one auxiliary HTFW pumps, of which only one of the main pumps is normally in operation. The auxiliary pump is provided for use in port. If the HTFW pumps stop, a small cooling medium flow will still be present as long as one of the LTFW pumps is running. If the main engine has been stopped for a long period of time, it is required to heat the HTFW with the preheater, which is heated with steam.

The venting valve in HTFW line after cylinders should always be open. Its purpose is to keep a small amount of water flowing from the cylinders to the expansion tank in order to release entrapped air in HTFW system. The system is indicative only.

The effect of cavitation is modelled for the HTFW pumps. The auxiliary HTFW pump is mainly used when in harbour or during blackout.

The HTFW system is controlled by a PID controller, which operates a three way mixing valve, mixing hot water from main engine outlet with cold water from the LT/HT junction. The temperature sensor may be moved from the outlet to the inlet of the ME on variable page 1011.



If the FW of the main engine outlet is at boiling point, fresh water evaporation is simulated. The resulting low water level in the expansion tank leads to low pressure in the fresh water system. The HTFW pumps are especially liable to cavitate under these low pressure conditions, causing a reduction in ME cooling.

The static pressure in the fresh water system is given by the water level in the fresh water expansion tank. There is a small constant consumption of fresh water due to leakage and evaporation. The expansion tank must be filled periodically. In bad weather, unsteady expansion tank level is simulated, and false alarms may arise.

Actuator type can be changed from variable page.

### **Operation procedure**

#### **1. Pre-heating**

- 1.1 During out of service periods or if stopped for a prolonged period during manoeuvre the main engine must always be pre-heated. Insufficient pre-heating of the main engine before starting may cause misalignment of the main bearings and fresh water leaking.
- 1.2 Once steam is available, open the HTFW inlet valve and close the by-pass valve.
- 1.3 Correct pre-heating temperature is 60 - 65°C.

#### **2. Jacket cooling water**

- 2.1 Check the position of all valves in suction and discharge line and start the auxiliary jacking cooling water pump locally.

- 2.2 Normal temperature controller set point is 80°C
- 2.3 At Stand-by the main cooling pump should be started and put into AUTO from the PowerChief Pump Control panel. The second pump should be in St-By.
- 2.4 During normal operation with engine running the preheater would be by-passed and shut off.
- 2.5 The expansion tank level should be checked periodically.

#### **3. Shut down procedure**

- 3.1 Prior to stopping the engine the fresh water generator must be secured and the jacket cooling water by-pass opened to prevent under cooling of the jackets during manoeuvring.
- 3.2 During short stops the main HTFW pump may be left running and the jacket preheater put in use.
- 3.3 For longer stops use the auxiliary HTFW pump and the jacket pre-heater.
- 3.4 If securing the engine for maintenance shut off steam to preheater until temperature has cooled to about 40C or ambient engine temperature and stop all pumps.

To secure the LTFW system all plant must be shut down and then all LTFW pumps may be stopped

<This page is intentionally left blank>

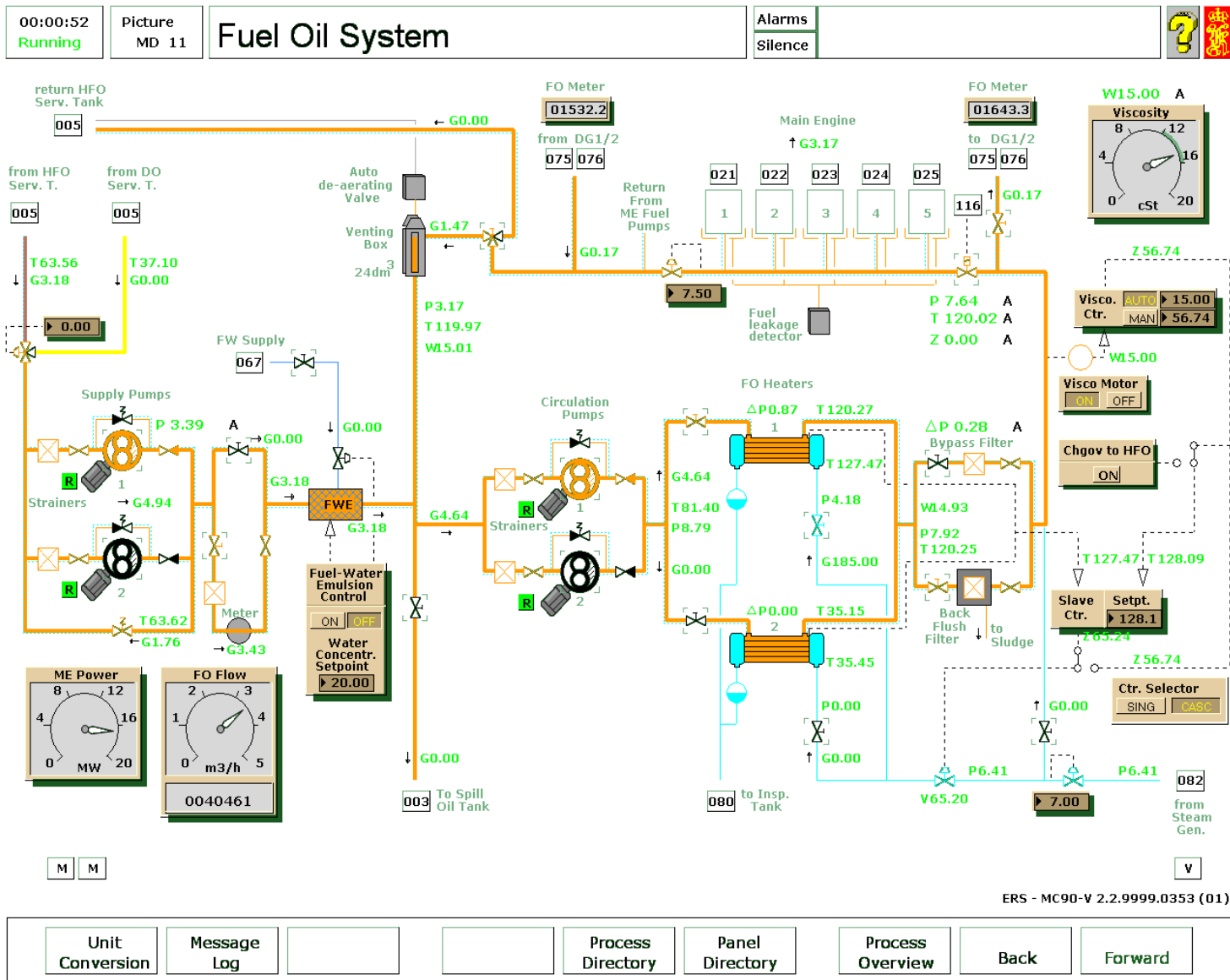

### 3.7 Fuel Oil System MD11

#### General

The purpose of the fuel oil service system is to preheat the fuel oil to correct injection viscosity, to fine-filter the fuel oil and to supply the main engines and the generators with a continuous flow of fuel oil at a correct pressure.

All engines are running at the same viscosity and intended to operate on heavy fuel oil at all times, full power, manoeuvring and in port.

Operation on diesel oil is only recommended during abnormal conditions and during major overhaul of the fuel oil system.

The system is capable of preparing heavy fuel oil with a viscosity of 700 cSt. at 50°C and arranged as a pressurised fuel oil system in order to prevent foaming and high-pressure fuel oil pump cavitation.

#### Description

Two supply pumps take suction from the heavy fuel oil service tanks or from the diesel oil service tank through an adjustable 3-way mixing valve. The supply line from each service tank is equipped with non-return valves in order to prevent confluence.

The supply pumps discharge to the venting tank at a pressure of approx. 4 bar. The total amount of fuel oil supplied to the venting box is measured by a flow meter (totaliser) equipped with a bypass valve.

The capacity of each supply pump exceeds the max. consumption of the main engines and the generator engines combined.

Situated between the fuel oil meter and the venting box is a **Fuel-Water Emulsion Control Unit** which is designed for emulsification

of the fuel to reduce the NOx values in the exhaust gas from the engines. One very important thing to remember when adding water to the fuel is that to maintain the same engine power, the fuel link must increase. Therefore all the parameters or limits depending on the fuel link position must be adjusted (with the same relative values as the actual water fraction)

The venting box can be drained to the spill oil tank through a drain valve.

Two fuel oil circulation pumps take suction from the venting box and/or the fuel oil supply pumps and discharge to the fuel oil circulating line, supplying fuel oil to the injection system of the main engines and of the generators engines. The circulating line is equipped with two steam heated fuel oil heaters, one backflush fuel oil filter and one bypass filter. The capacity of each heater is sufficient for the max consumption for the main engines and the generators engines.

It is possible to run the generators engines on diesel oil with the main engine on heavy oil.

The capacity of each circulating pump exceeds the max consumption of the main engines and the generators engines combined.

Excess fuel is normally returned to the venting box. Provision is also made to return the fuel oil to the service tanks through a 3-way changeover valve.



An adjustable (5-10 barg) back-pressure valve maintains a constant pressure in the circulation line.

The fuel oil line to the main engines is equipped with a remotely operated emergency shut off valve, operated from the Emergency Operating Panel (outside engine room).

Steam for heating of the venting box and all fuel oil lines (steam tracing) is supplied through an adjustable (0-10 barg) steam reduction valve. Steam for fuel oil heaters and steam tracing can be shut off by stop valves

### **Fuel oil viscosity control**

The viscosity controller positions the steam valve of the fuel oil heater directly (single PID loop), or indirectly by adjusting the set point of a separate slave controller (cascade control).

The feedback signal to the slave controller is the mean tube metal temperature of the fuel oil heaters (High Selected).

At low load, it may prove to be necessary to stabilise the controller by reducing the steam supply to the fuel oil heaters.

This controller can be configured in cascade. A controller connected this way will be more stable and less sensitive to supply steam pressure than with a direct connected PID control.

### **Operation procedure**

#### **1. Preparation and starting on diesel oil**

##### Supply system

- 1.1 Set 3-way valve into diesel oil position (100% for pure diesel oil).
- 1.2 Ensure sufficient level in diesel oil service tank and drain the tank.
- 1.3 Line up system from diesel oil service tank to venting tank – by pass valve for fuel oil flow meter normally to be closed.
- 1.4 Close venting box drain valve.
- 1.5 Start one of the supply pumps manually and check the discharge pressure and flow.

##### Circulation system

- 2.1 Open valves to one of the fuel oil heaters and the back flush filter.
- 2.2 Check that the main engine fuel oil emergency shut off valve is open
- 2.3 Open fuel oil shut off valves for both main engines and the supply valve for the generator engines.
- 2.4 Return line valve pressure controller must be set to 7-8 barg.
- 2.5 Check that the 3-way valve in the return line is set to return to venting tank.
- 2.6 Set fuel oil viscosity controller into Manual
- 2.7 Check that the valves for steam supply to fuel oil heaters and steam tracing is closed
- 2.8 Start one fuel oil booster pump manually and check discharge pressure and flow





2.9 Select auto stand by for supply pumps and for booster pumps at the PowerChief – Pump Control panel.

**NOTE:** If steam system is not shut off effectively by closing the stop and control valves of the steam system there is a risk of heating the diesel oil. Too high temperature of the diesel oil may cause poor lubrication of high-pressure pump's plunger and of fuel oil nozzle needle valve due to low viscosity. This again may cause piston or needle valve to seize.

**Note:** If there is no fuel oil consumption from the fuel oil supply system the supply pumps must be stopped in order to avoid damage of the pump due to high temperature.

### 3. Changing from diesel oil to heavy fuel oil.

- 3.1 HFO purifier to be in operation
- 3.2 Ensure sufficient level in the HFO service tank and proper temperature in order to get a suitable oil viscosity.
- 3.3 Drain the tank of any water.
- 3.4 Line up the system from HFO service tank to 3-way mixing valve.
- 3.5 Open steam valves to selected FO heater.
- 3.6 Open steam valve for steam tracing.
- 3.7 Set steam line pressure controller to desired setting. (5-8 barg) and check steam pressure.
- 3.8 Set viscosity controller into Auto and set point at 11-15 cSt
- 3.9 Gradually change value of 3-way mixing valve to pure HFO while checking that the controller keeps the viscosity within appropriate limits.

Quicker change-over can be obtained with return to service tank open. This, however, may cause needle valves to seize in fuel injectors.

### 4. Changing from heavy fuel to diesel oil

- 4.1 Slowly reduce the temperature on HFO by adjusting the viscosity controller manually.
- 4.2 When temperature drops, gradually mix in diesel oil by adjusting the 3-way mixing valve
- 4.3 Observe the rate of temperature reduction. Too quick temperature drop can cause fuel oil high-pressure pump's plungers to seize due to plunger-liner contraction / reduced lubrication.

**Note:** If for some reason venting box must be drained, the three-way valve can return the fuel oil to the settling tank(s).

With main engine running, best result in viscosity control is obtained with controllers in CASCADE, VISCOSITY CONTROLLER in AUTO.

The main engine and generator engines are usually stopped and started with HFO in fuel lines. Diesel oil is used if engines are to be stopped for a prolonged period (dry-docking) or when conducting major overhauls to fuel system. If ambient temperature is extremely low, or if steam system is out of commission, change to diesel oil before stopping or empty lines by changing to diesel oil and re-circulating oil back to HFO service tank.



### **Model particulars**

If the plant is shut down with no heating, the oil in the venting tank will cool down because of heat loss to surroundings. The oil viscosity in the venting tank is computed, depending on temperature and possible dilution by diesel oil.

If a water leakage in the service tank heater has occurred it will collect in the vent tank and disturb the running of the diesel engines. The venting tank can be drained or emptied to the Spill Oil tank.

If the viscosity at the booster pump inlet is high, the fuel oil booster pump discharge pressure will decrease.

The oil viscosity in the circulating line is computed, depending on temperature and possible dilution by diesel oil.

The flow resistance in fuel oil heaters and filters is dependent on viscosity. A pressure drop in fuel oil filters and fuel oil heater results in a correspondingly drop of fuel oil pressure at the DG's and ME's high-pressure pumps.

Above a viscosity of approximately 600 cSt the oil is beyond the pumping limit.

If the rate of temperature reduction/rise when changing from HFO to diesel oil is too high, some of the HP injection plungers might stick due to plunger liner contraction/reduced lubrication.

The oil delivery from the booster pumps is reduced if the suction pressure drops below a certain limit.

### **Fuel oil gassing**

If the fuel oil temperature after the fuel oil heaters rises higher than the fuels boiling temperature "gassing" of the oil is simulated. Fuel oil gassing causes that:

- the running of the main engine is disturbed.
- the signal from the viscosity meter becomes very noisy.
- Normally HFO gassing develops above 135C and for DO above 80C adjustable

### **Fuel oil quality**

Fuel oil quality (heating value, density, and viscosity) can be set from variable page 1129.

<This page is intentionally left blank>

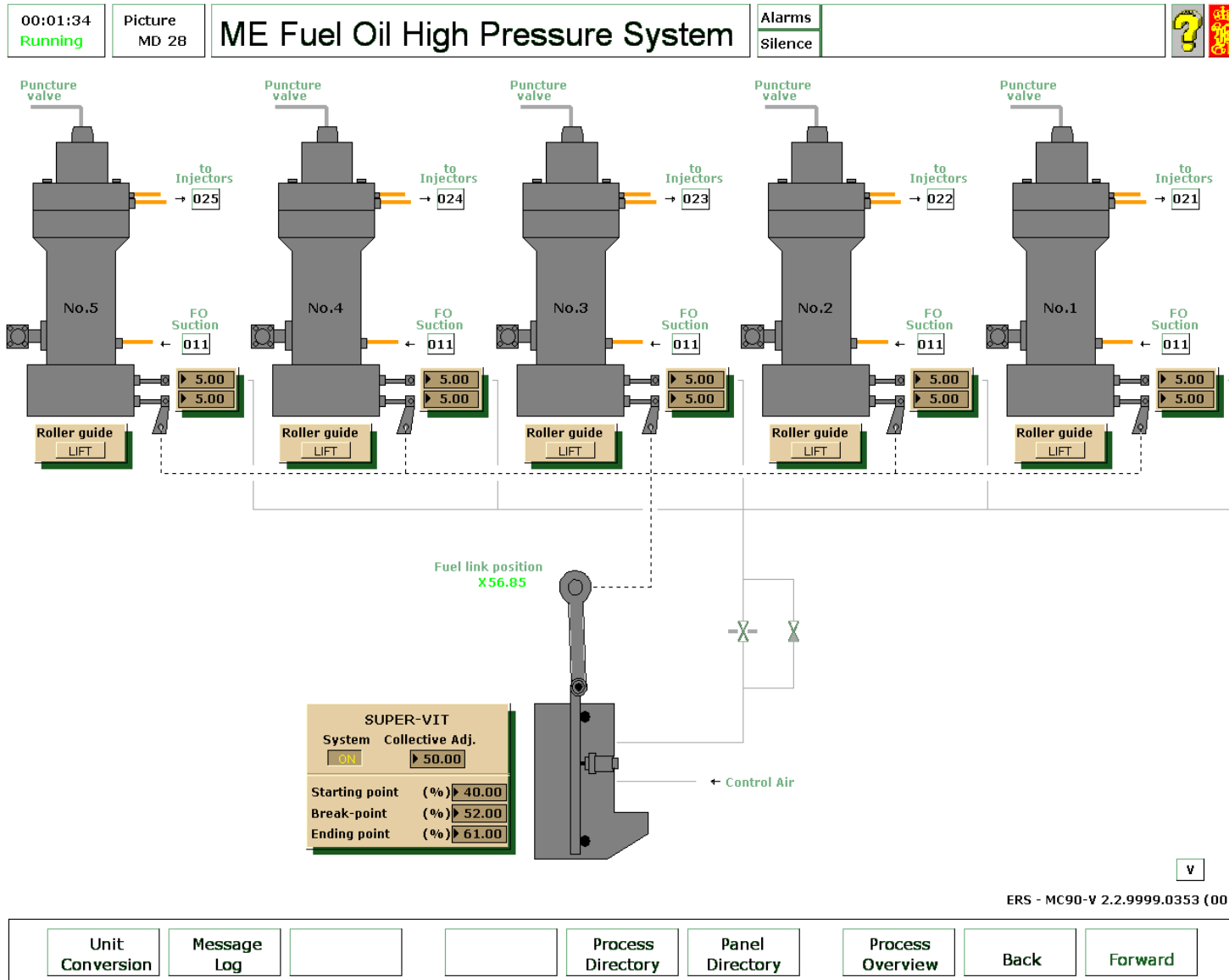

### 3.8 ME Fuel Oil High Pressure System MD28

#### General

The screen indicates the Variable Injection Timing (VIT) system for the engine. VIT will advance the fuel timing to raise the combustion pressure at engine loads below 100%, and hence improve the fuel efficiency. The start and finish of the fuel advancement can be adjusted over the range of the engine, by means of the starting and ending point.

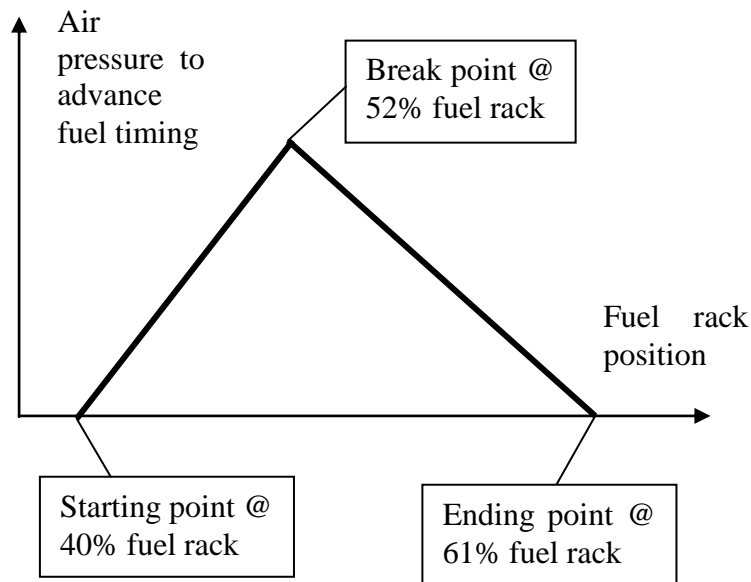

To adjust the timing of the fuel pumps, three options are available

- The individual adjustment at the upper control lever (to compensate for the wear within the fuel pump the timing would be advanced. 1mm reduction in the fuel pump setting is approximately  $0.8^\circ$  advancement.)
- The collective adjustment input (to compensate for the quality of the supplied fuel. Reducing the collective setting by 10% would advance all fuel pumps by  $0.8^\circ$ )
- The variable adjustment due to fuel rack position (to increase the fuel efficiency of the engine. Dependant upon the start, break and end points, with default settings of 40, 52 and 61% to achieve actual engine characteristics)

The actual VIT advancement applied to each fuel pump is displayed beside the upper fuel pump control lever, and is the summation of the above three options.

Hence each individual fuel pump can be adjusted to provide the optimum fuel timing with regard to fuel type and quality, and engine load. Excess fuel timing advancement should be avoided as this will:

- Increase the maximum combustion pressure, and hence cylinder and bearing loading
- Affect the ability of the engine to start effectively

Following adjustments to the VIT system the operator should monitor the combustion pressure over the complete engine load range, especially from 50 – 100% load using the Cylinder Indication screen MD120.

00:01:00 Running	Picture MD 13	<b>ME Turbocharger System</b>	Alarms			
			Silence			

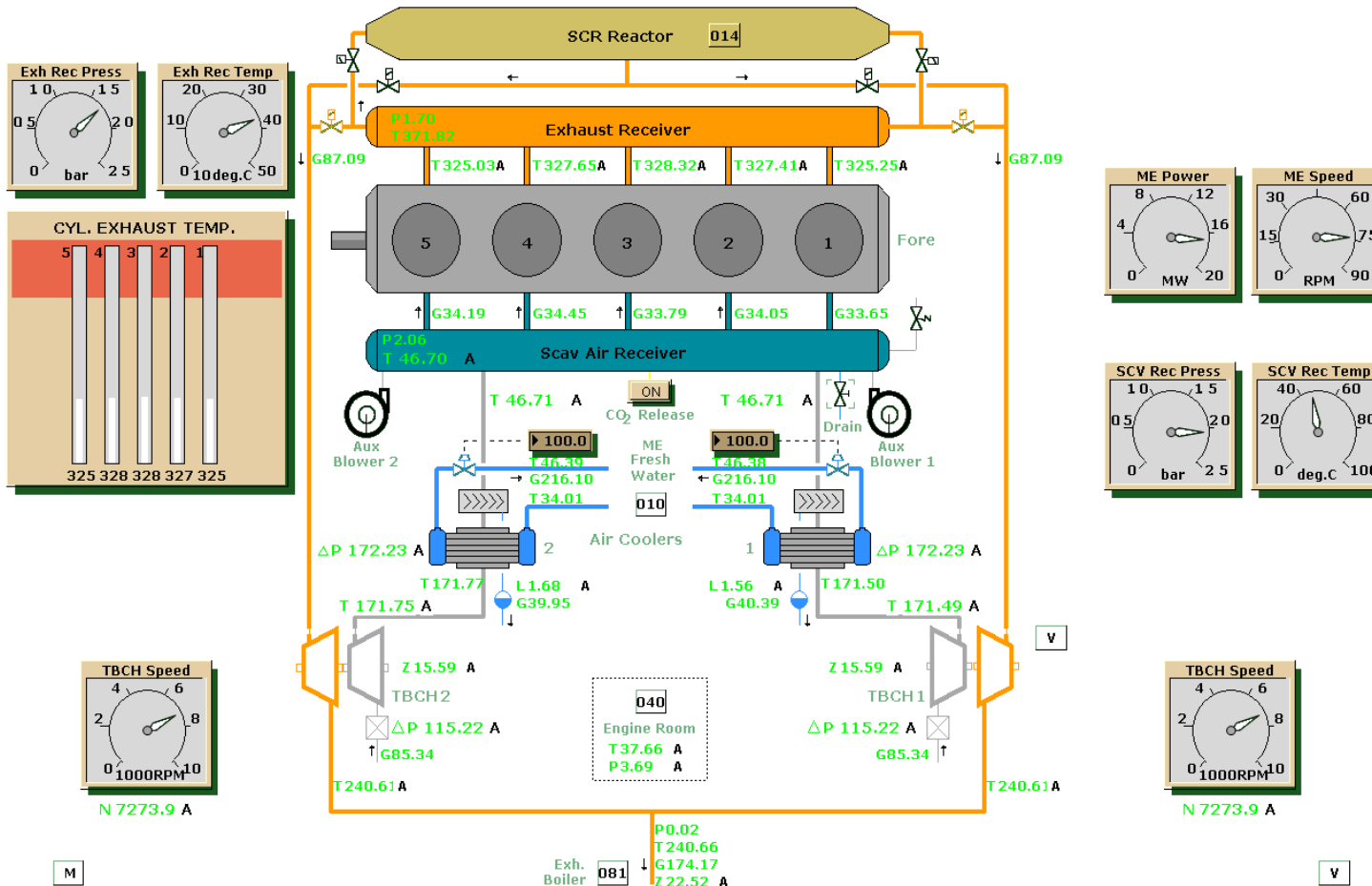

ERS - MC90-V 2.2.9999.0353 (00)

Unit Conversion	Message Log		Process Directory	Panel Directory	Process Overview	Back	Forward
-----------------	-------------	--	-------------------	-----------------	------------------	------	---------

### 3.9 ME Turbocharger System MD13

#### General

The main engine is supercharged by two constant pressure turbochargers. The turbo-charged air is cooled in a fresh water-cooled air cooler before entering the main engine.

The air cooler must be kept clean to enable it to provide a sufficient amount of cool air to the engine. Hot air will lead to high exhaust temperatures, greater heat losses and increased specific fuel oil consumption.

After the air leaves the air coolers, it enters the demister units that are fitted to reduce the water content of the air. Water is drained off the demister units via the water trap, where the level and flow of the drained water can be noted from the screen display.

Dirty turbo-charger air filters throttle the scavenging airflow and will result in reduced engine performance.

The exhaust gas from the main engine cylinders enters the common exhaust gas receiver. From this receiver the exhaust gas can either flow direct into the waste heat exhaust gas boiler or via the Selective Catalytic Reduction (SCR) Receiver before entering the Exhaust Gas Boiler.

The exhaust boiler must be kept clean. High back pressure reduces scavenging air flow and engine efficiency, especially at high power.

The turbo-charger model is composed of two separate units, a centrifugal air compressor and a single stage gas turbine.

Major variables influencing the compressor torque:

- discharge pressure (air receiver)
- suction pressure (air filter differential pressure)
- air inlet temperature (density)
- compressor speed

Major turbine torque variables:

- exhaust receiver pressure
- exhaust receiver temperature
- back pressure (exhaust boiler differential pressure)
- turbine speed

The turbo-charger speed is computed on the basis of the torque balance differential equation shared by the turbine and the compressor model units.

In the event of a scavenge fire a CO<sub>2</sub> release is provided.



## 1. Operation procedure

- 1.1. Line up the system by opening the fresh water cooling throttle valves to air coolers 1 and 2.
- 1.2. Ensure the scavenge air receiver drain is closed
- 1.3. Check that the SCR Reactor is isolated at engine start-up
- 1.4. Check that the Aux. Blowers 1 and 2 are in AUTO and running. These are operated from MD20 or MD102. Preset values for start/stop of aux. blower is respectively 0.2 bar and 0.4 bar.

**Note:** Differential pressure across cooler and air inlet filter should be checked regularly.

## 2. In the event of a scavenge fire

- 2.1. Indicators of scavenge fire
  - High scavenge air temperature
  - One or more cylinder exhaust temp high
  - Engine running rough
  - Turbochargers surging
- 2.2. Slow down and stop when safe to do so
- 2.3. While waiting to stop
  - Shut off fuel to affected cylinder(s)
  - Increase cylinder oil slightly
- 2.4. Stop aux. blowers
- 2.5. Release CO<sub>2</sub>





<This page is intentionally left blank>

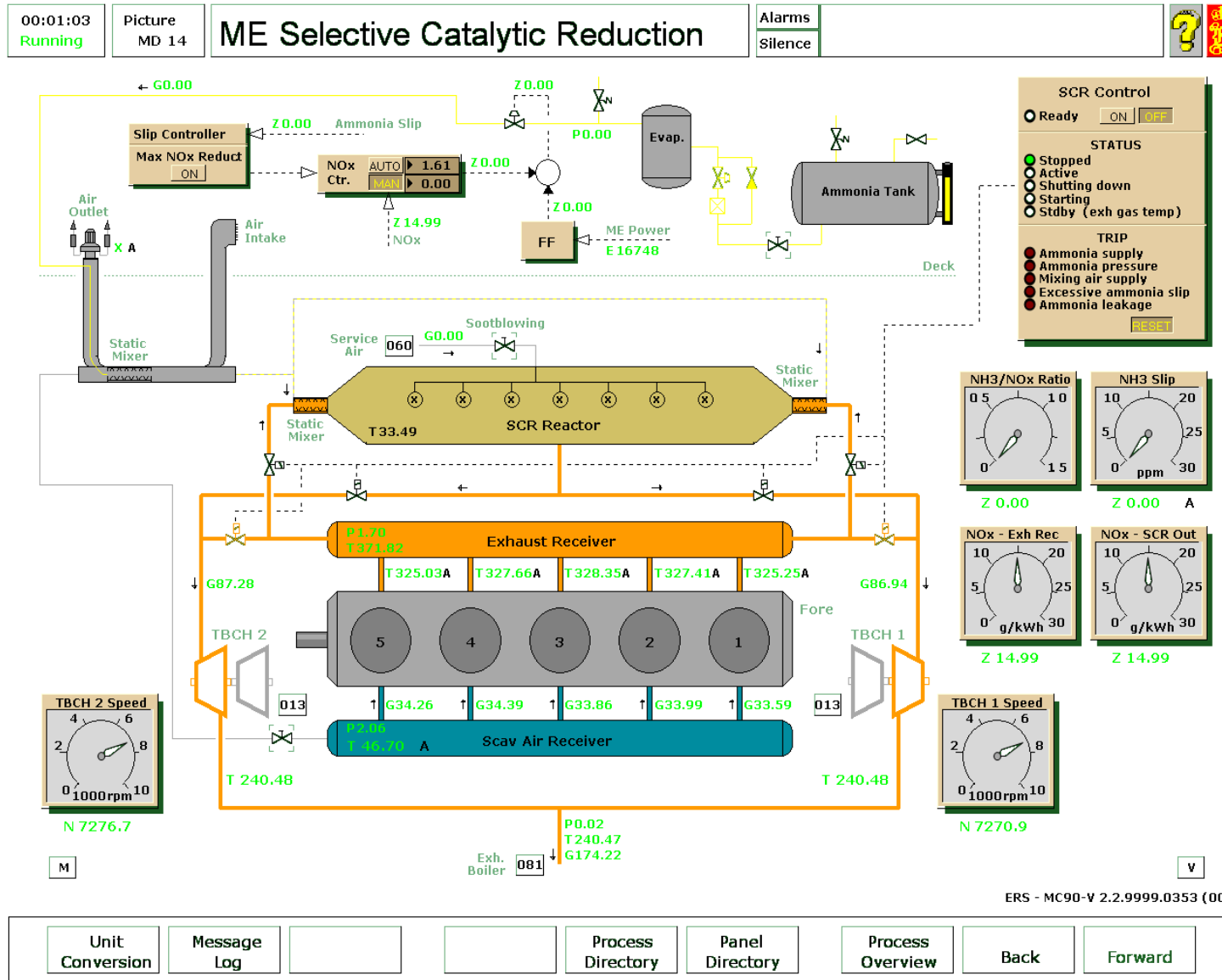

### 3.10 ME Selective Catalytic Reduction MD14

#### General

The Selective Catalytic Reduction unit is provided to reduce the environmental impact of the diesel engine by minimising the Nitrogen Oxides (NO<sub>x</sub>) emitted from the main engine exhaust stream.

The SCR unit is used to treat the exhaust before it enters the turbocharger. Ammonia is added to the gas stream, and the mixture then passes through a special catalyst at a temperature between 300 and 400°C. Within the SCR Reactor the hot exhaust gases that contain NO<sub>x</sub> gases are mixed with the ammonia stream. This reduces the NO<sub>x</sub> to N<sub>2</sub> and H<sub>2</sub>O, as detailed:

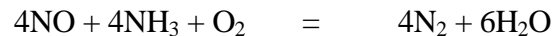

If the temperature of reaction is too high (above 490°C), the ammonia burns and does not react, and at low temperatures (below 250°C) the reaction rate is low and the catalyst can be damaged.

The quantity of ammonia added is pre-programmed into the controlling processor. This provides the base control, with a feed back link provided by the NO<sub>x</sub> measurement taken from the exhaust stream. Using the feedback link alone would produce inaccurate control due to the sluggish nature of the reaction process; hence a feed forward signal from the main engine actual power is used to modify the controller output.

The Slip controller will adjust the NO<sub>x</sub> controller set point down with the specified rate when the slip is below the slip set point (default 3ppm), and up when the slip is above. This “optimal” mode will be turned off if the NO<sub>x</sub> controller is not in auto, or if the control state is not “active”, and it has to be manually switched on again. The SCR slip controller controls the rate at which the ammonia flow is changed. Within the pop-up window, these settings can be adjusted, with the default setting of increase 0.02 g/kWh/sec, and decrease 0.01 g/kWh/sec.

The quantity of ammonia which can be added is limited, as excess amounts produce "ammonia slip", by which neat ammonia leaves with the exhaust stream. Thus both ammonia and NO<sub>x</sub> levels are recorded in the exhaust stream, and levels of 10ppm and 5g/kWh expected values. These values are reduced from the engine cylinder exhaust NO<sub>x</sub> level in the region of 20 g/kWh.

The ammonia is supplied as pressurised water free ammonia feed. The process units are contained within a safety area, as ammonia is combustible. Thus lines are double walled, and leak detection and appropriate venting of the storage and process areas must take place.



### Operation procedure

1. Line up the system by opening the scavenge air valve to the air / ammonia static mixer.
2. Open the outlet valve from the ammonia tank so that the ammonia vapour pressure rises.
3. Input 5 g/kWh as the set value for the NO<sub>x</sub> controller, and place the controller in AUTO.
4. When the SCR control ready light is lit, then the SCR control can be selected
5. This will allow the automatic valves to change the exhaust gas flow into the SCR Reactor

The SCR control panel indicates the status of the system, with the following indications:

- Stopped. When the system is non-operational
- Active. The system is operational, hence the SCR Reactor bypass exhaust valves are closed and all the exhaust gas flow is directed through the reactor, and the ammonia inlet to the static mixer is open.
- Shutting Down. The system is changing from active to stopped, by changing the exhaust gas flow path from the exhaust receiver direct to the turbochargers. Note that during the shut down period (15 second default setting) both the bypass and direct flow paths are open, to prevent a sudden change in the turbocharger operation parameters, and to allow the reactor to gradually cool down.
- Starting. The system is changing from stopped to active, by directing the exhaust gas flow from the exhaust receiver to the SCR Reactor. During the starting period (default 30 seconds) the SCR bypass and inlet /outlet valves are open to allow a

gradual heating up of the reactor, and prevent a possible turbocharger surge by rapid change to the turbocharger turbine speed.

- Standby (exh gas temp). When the control system is selected ON, the exhaust temperature must be within pre-set temperatures to enable the system to start. These temperatures are adjustable, and the default settings are low limit 250°C or high limit 490°C.

The system will cease to operate if a trip is active. This will occur if any of the following occurs:

- Ammonia supply. When the ammonia supply is insufficient due to a low level in the ammonia tank, then the system will trip.
- Ammonia pressure. When the ammonia pressure is above 2.5 bar, then the system will trip.
- Mixing air supply. When the scavenge air flow into the static is low, then the system will trip.
- Excessive ammonia slip. When the quantity of ammonia input to the reactor is excessive, then the level of ammonia within the exhaust stream rises. This slip of the ammonia is measured, and when this reaches 60ppm for over 30 seconds then the system will trip.
- Ammonia leakage. As ammonia can produce a flammable and/or explosive mixture with air, any leakage in the deck housing containing the ammonia system is monitored and will cause the system to trip.



<This page is intentionally left blank>

00:01:13 Running Picture MD 20 **ME Local Control** Alarms Silence ? 

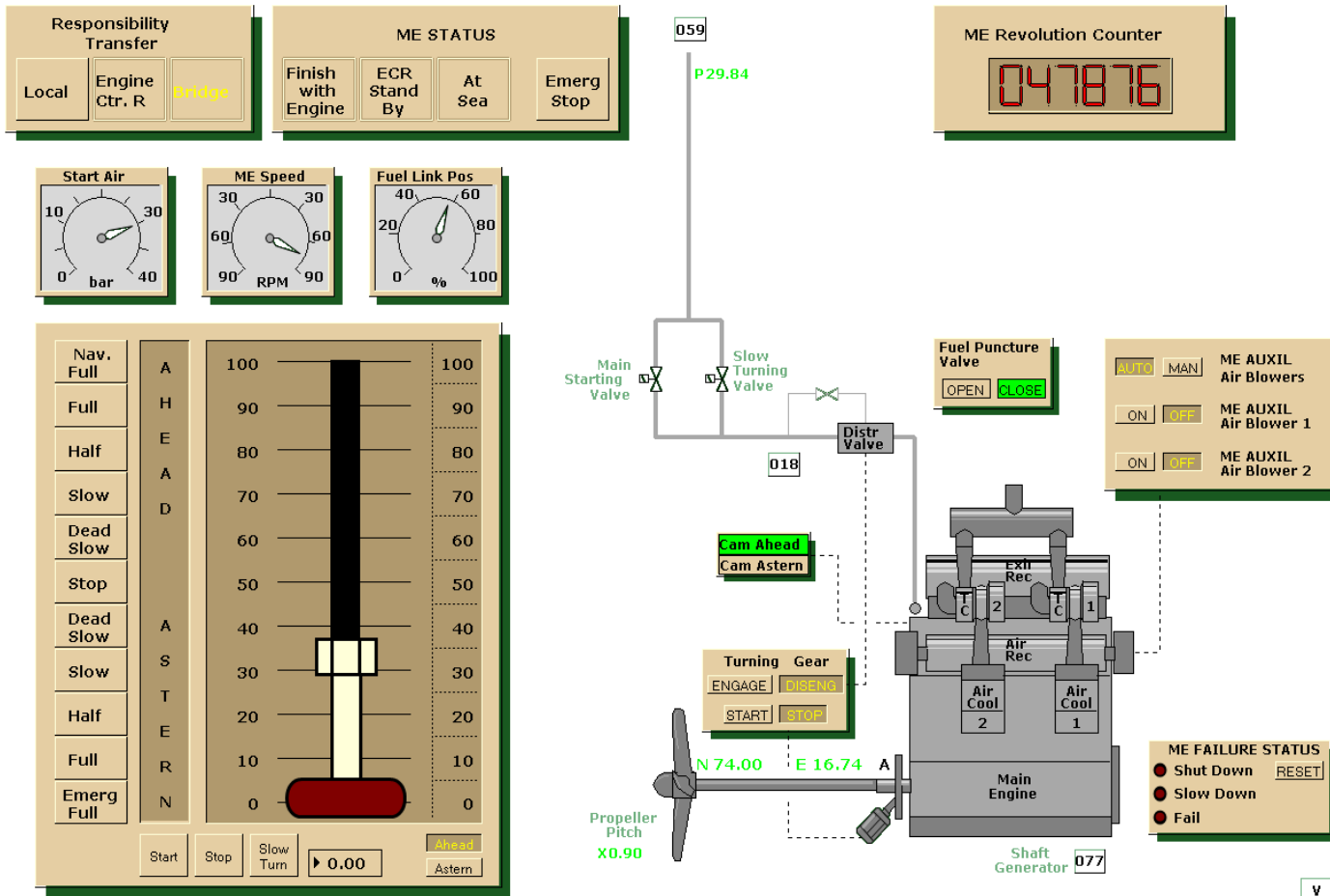

ERS - MC90-V 2.2.9999.0353 (02)

Unit Conversion Message Log Process Directory Panel Directory Process Overview Back Forward

### 3.11 ME Local Control MD20

#### General

Local control of the main engine is provided to enable operation and control of the main engine should a defect or malfunction of the main control or manoeuvring system occur.

In Local control the automatic thermal load programme, main governor functions, and slow down protection is overridden.

The local control panel contains the following operating functions:

- Local fuel control lever. This is directly connected to the fuel linkage. The fuel control lever can be moved by either a direct input, or by selecting a fixed step on the right of the fuel control lever.
- Emergency telegraph. This is automatically linked with the Bridge telegraph when the local control is selected by both the Bridge and Local Control stations.
- Indicator cocks. These can be opened or closed. The cocks would be opened during engine shut down, and closed when the engine is started.
- Auxiliary Blowers. These can be stopped or started in manual control, as well as being placed in automatic control for blower stop and start via the pressure switch on the scavenge air manifold.
- Turning gear engage and disengage. Once the turning gear is engaged, it can be started to turn the engine before the engine is started. This will ensure that no water has collected within the main engine cylinders. NB The

indicator cocks should be opened whilst the turning gear is operating.

There are status indicators for:

- Fuel Puncture valve. The stop command for the engine will open the puncture valves. When the engine is running normally the puncture valves will be closed.
- Camshaft position. This indicates whether the camshaft is in the ahead or astern position.
- ME Failure status. This indicates locally whether there is a shut down, slow down or failure present. All three main engine protection system can be reset at this local panel.

#### Starting procedure of the main engine at the Local Panel

1. The Responsibility Transfer is set to Local.
2. The Bridge should select ECR Stand By to indicate that engine operations are required.
3. The turning gear should be disengaged.
4. The Indicators Cocks should be closed.
5. The manoeuvring system should be prepared with starting air and control air available.
6. The ME Failure status should be checked, and any failure reset.
7. The auxiliary blowers should be placed on automatic, and the auxiliary blowers should start.
8. The Emergency telegraph should be observed, and any command from the Bridge acknowledged.
9. Select either Ahead or Astern depending on the telegraph command.



- 
10. Admit Start Air by pressing the Start button, observe that the engine RPM rises in the correct direction.
  11. At about 20rpm the Start button should be released and the fuel lever moved away from the stop position to fulfil the Bridge request. The puncture valve will automatically close.
  12. To stop the engine, move the fuel lever to zero.
  13. If a stop has been prolonged the slow turn can be used to maintain engine readiness. Select Slow Turn then press Start. Observe the engine rpm.
  14. Using the Stop button opens the fuel puncture valves giving an emergency stop of the engine.



<This page is intentionally left blank>

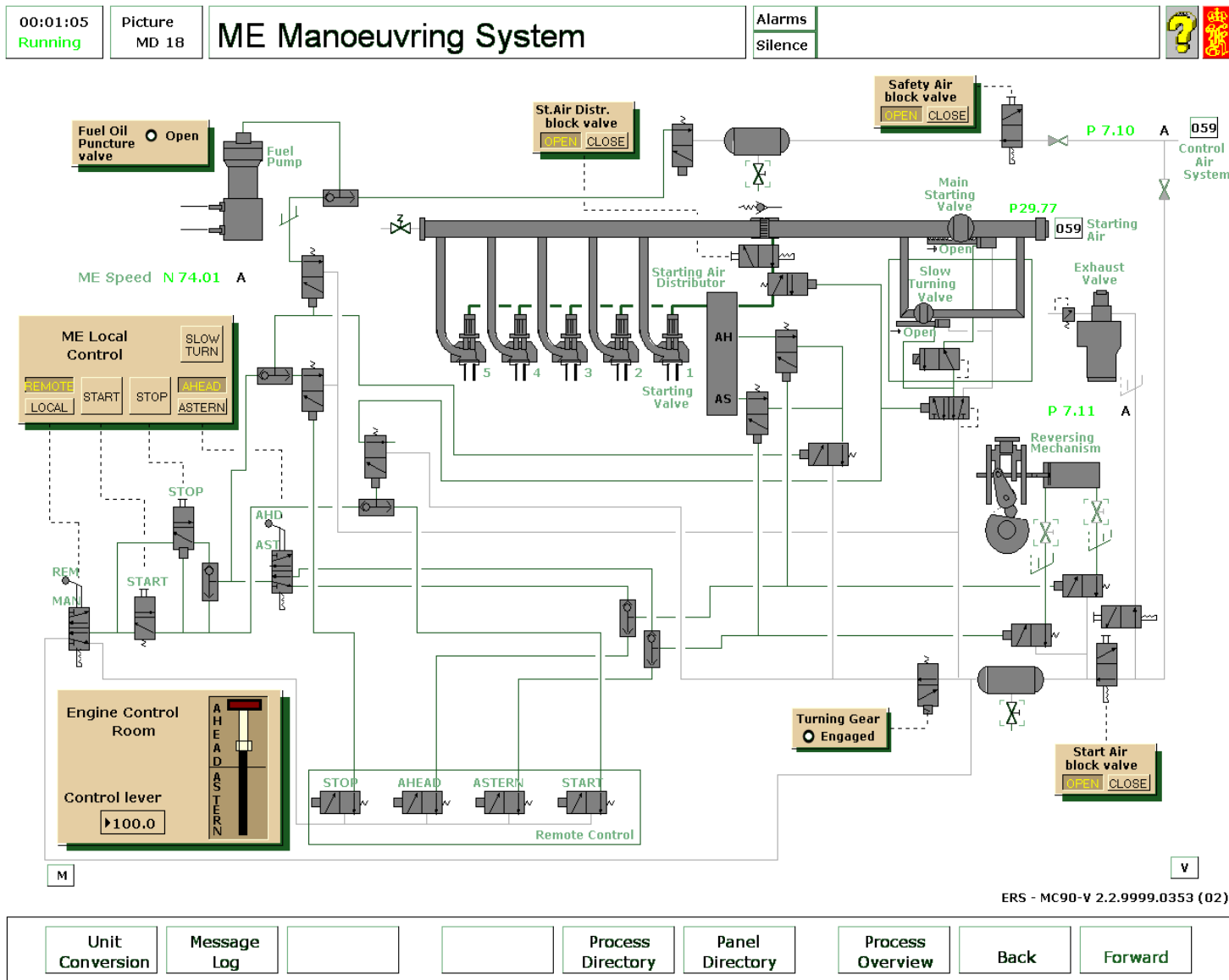

## 3.12 ME Manoeuvring System MD18

### General

This drawing illustrates the components required to start, stop and reverse the main engine. The process diagram shows the main inputs from the local control and engine control room that starts the engine.

Before the engine can be started in any selected control position the following valve position should be set:

1. The safety air block valve 16 should be open. This valve supplies the air to the fuel pump puncture valves should an engine safety trip be activated.
  2. The starting air distributor block valve 118 should be open. This valve supplies the pilot air to open the individual cylinder starting valves.
  3. The starting air block valve 1 should be open. This valve supplies the control air to the manoeuvring system.
  4. The turning gear valve 115 should be disengaged. This supplies the control air to valve 33 and hence would block the start sequence if engaged.
  5. The pressure of the service air supply should be checked to be above 6.5 bar
  6. The pressure of the starting air supply should be checked to be above 25 bar.
- ### Engine START operation in local control
1. To control the engine system at the engine side control, the local control is selected at the ME Local Control station. This will cause valve 100 to pressurise valves 101 and 102.
  2. Once in local control, the engine can be started, stopped and reversed at the local control panel.
  3. To start the engine the start button is pressed which will activate valve 101. This action will activate valves 33, 25 and 117.
  4. When 33 is activated, both valves 26 and 27 will operate. Valve 26 will supply the starting air distributor with pilot or starting air valve operating air. Valve 27 will cause valve Main starting valve to open pressurising the starting air manifold with high pressure 30 bar starting air.
  5. When 25 is activated, the fuel pump puncture valves are pressurised to ensure that fuel is not admitted during the air start admission period.
  6. When 117 is activated, control air is admitted to valves 14 and 15. The selection of valve 14 or 15 is determined by the selection of ahead or astern at the ME Local Control station, and activates the starting air distributor to the ahead or astern position. Once the starting air distributor is in the end position for ahead or astern the starting air distributor will allow the control air, admitted via valve 26, to the correct cylinder starting valve causing the engine to rotate in the desired direction.
  7. The engine speed will now increase due to the admission of the starting air. Once sufficient engine rotational speed has been reached (above 18 rpm), then the start button is pressed once again to release the start command. Releasing the start command will vent the valves 33, 25 and 117.



8. The speed of the engine would now be regulated by the position of the fuel control lever on MD20.

#### **Engine STOP operation in local control**

1. To control the engine system at the engine side control, the local control is selected at the ME Local Control station. This will cause valve 100 to pressurise valves 101 and 102.
2. Once in local control, the engine can be started, stopped and reversed at the local control panel.
3. To stop the engine the stop button is pressed which will activate valve 102. This action will activate valves 25 and 117.
4. When 25 is activated, the fuel pump puncture valves are pressurised to stop the fuel pump admitting any more fuel and hence the engine will stop.
5. When 117 is pressurised, the starting air distributor is pushed to the ahead or astern position (as dictated by valve 105), but the engine will not start as valves 26 and 27 are not energised.

#### **Engine AHEAD operation in local control**

1. To control the engine system at the engine side control, the local control is selected at the ME Local Control station. This will cause valve 100 to pressurise valves 101 and 102.
2. Once in local control, the engine can be started, stopped and reversed at the local control panel.
3. To start the engine in the AHEAD direction, then the Ahead button is pressed which will cause valve 105 to pressurise the Ahead signal line. This will in turn activate valves 14 and 10.
4. When 14 is activated, the starting distributor will be moved to the ahead position when the start signal is activated.

5. When 10 is activated, the fuel pump reversing mechanism on all five fuel pumps will be moved to the ahead position, once the engine starts to move in the ahead position.
6. The selection of the ahead position is maintained whilst the engine is running. If the engine is to be operated in the astern direction, then the engine should be stopped first.

#### **Engine ASTERN operation in local control**

1. To control the engine system at the engine side control, the local control is selected at the ME Local Control station. This will cause valve 100 to pressurise valves 101 and 102.
2. Once in local control, the engine can be started, stopped and reversed at the local control panel.
3. To start the engine in the ASTERN direction, then the Astern button is pressed which will cause valve 105 to pressurise the Astern signal line. This will in turn activate valves 15 and 11.
4. When 15 is activated, the starting distributor will be moved to the astern position when the start signal is activated.
5. When 11 is activated, the fuel pump reversing mechanism on all five fuel pumps will be moved to the astern position, once the engine starts to move in the astern position.
6. The selection of the astern position should be maintained whilst the engine is running. If the engine is to be operated in the ahead direction, then the engine should be stopped first.

#### **Engine AHEAD START operation in remote control (Bridge or Engine control room)**

1. To control the engine system at one of the remote positions i.e Bridge or Engine control room, the remote control is selected at the ME Local Control station. The new control station position



will then be determined by the selection of either Bridge or Engine Ctr. Room on screens MD104 or MD110. This will cause valve 100 to block the air supply to valves 101 and 102.

2. Once in remote control, the engine can be started, stopped and reversed by operation of the single control lever.
3. To start the engine, the fuel lever is moved away from the stop position in the ahead direction, which will activate valves 86 and 90.
4. When 86 is activated, both valves 14 and 10 will operate. Both valves will ensure that the starting air distributor and fuel pump reversing mechanism are in the required ahead direction.
5. When 90 is activated, then valve 33 is activated. This will allow valves 26 and 27 to be activated. Valve 26 will supply the starting air distributor with pilot or starting air valve operating air. Valve 27 will cause valve Main starting valve to open pressurising the starting air manifold with high pressure 30 bar starting air.
6. Note the fuel pump puncture valves are still pressurised via valves 84, 38 and 25. This signal is only reached when the start level RPM is reached, about 20 rev/min.
7. The engine speed will now increase due to the admission of the starting air. Once sufficient engine rotational speed has been reached (start level RPM), then valves 84 and 90 are released, and following a small time delay valve 86. This will vent the valves 14, 10, 33, 26, 27, 33, 38, 25 and 117.
8. The speed of the engine would now be regulated by the position of the fuel control lever on either MD104 or MD110.

### **Engine STOP operation in remote control**

1. To control the engine in remote control, the regulating lever is placed at zero. This will cause valve 84 to pressurise valve 38, which in turn will activate valve 25.
2. When 25 is activated, the fuel pump puncture valves are pressurised to stop the fuel pump admitting any more fuel and hence the engine will stop.
3. Valve 117 is also pressurised, so that upon starting the starting air distributor will quickly move to the desired position.
4. The stop signal on valve 84 is only released when the regulating lever is moved above the start position and the engine has started.

### **Slow turn operation**

This engine is fitted with a slow turn arrangement that will slowly turn the engine when started. This arrangement would be manually selected when the engine has been stopped for over 30 minutes to prevent any possible cylinder damage from water leaking into the cylinder liner.

1. When the slow turn button is pressed then the valve 28 is activated. Any subsequent start sequence will only allow the small slow turning valve to open and block the opening of the main starting valve.
2. When the engine has rotated by at least one complete revolution, then the slow turn button is pressed once again to release valve 28, and hence allow the main starting air valve to open, and the engine speed should now increase to reach the start level RPM.

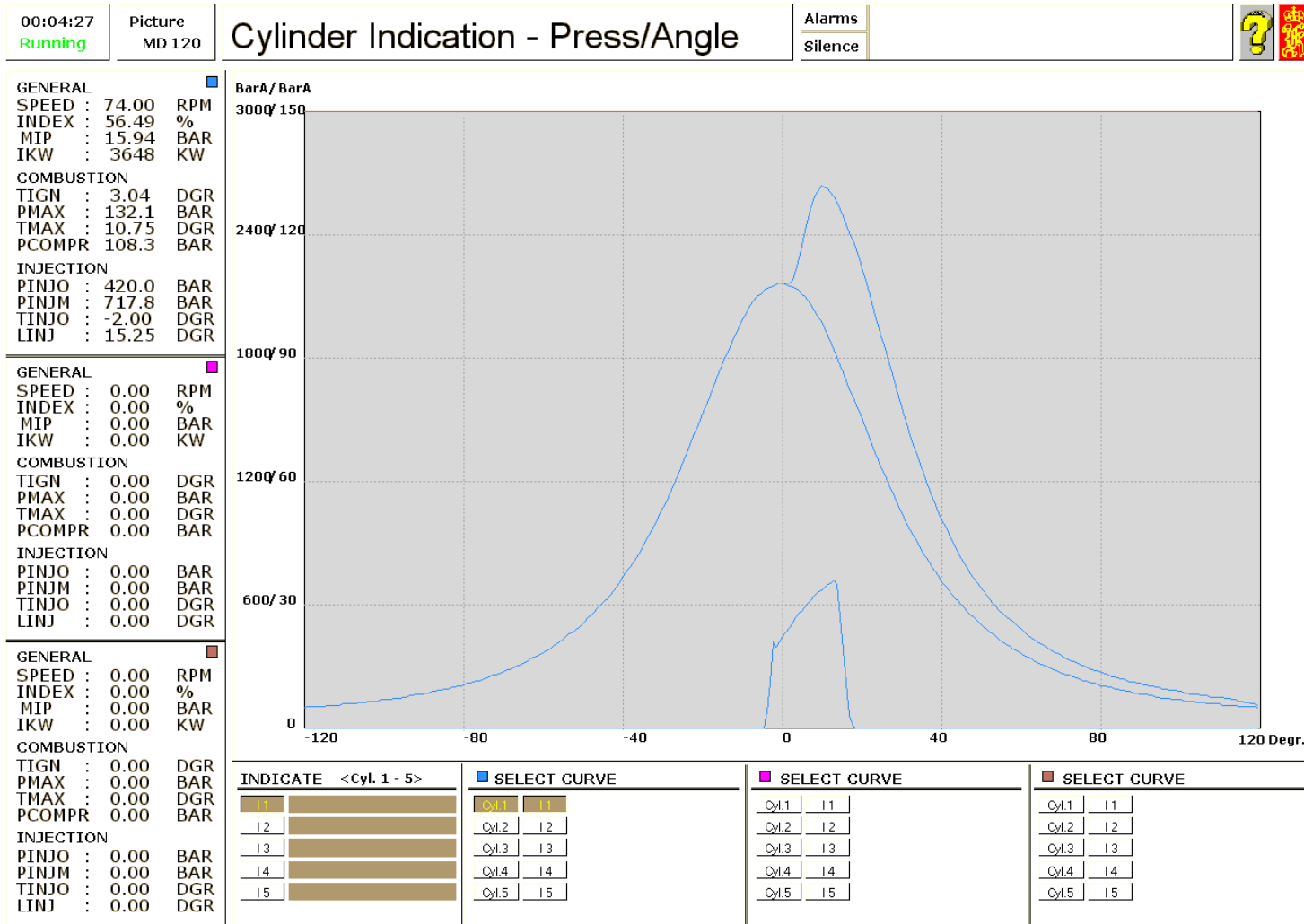

ERS - MC90-V 2.2.9999.0353 (00)

Unit Conversion	Message Log	Zoom	Spread	Process Directory	Panel Directory	Process Overview	Back	Forward
-----------------	-------------	------	--------	-------------------	-----------------	------------------	------	---------

## 3.13 Cylinder Indications MD120

### 3.13.1 Press/Angle

#### General

The cylinder indicator is used as a teaching aid and investigative system to enable regular monitoring of the engine cylinders to be undertaken. Faults within the combustion system can be located, and cleared using the malfunction editor function.

There are four different displays that can be selected to indicate the cylinder pressure conditions, namely pressure/angle (also called a draw card or out of phase diagram), pressure/volume (also called a power card, or in-phase diagram), the weak spring diagram, and the delta pressure/angle diagram. Each diagram can be used to illustrate differing combustion traits.

The pressure/angle diagram would be used for:

- Display the compression pressure curve, for comparisons with the other cylinders, to indicate cylinder sealing efficiency
- Display the approximate timing of the fuel ignition
- Display the fuel pressure trace (using the alternate pressure measurements of 0-3000bar.

To enable the cylinder indicator to measure the combustion pressure, the following actions are required:

1. Select one of the field button (I1 to I5) in the INDICATE column.

2. Type in your identifying comments in the INDICATE field to aid future fault identification.
3. Select the same field button (I1 to I5) in the SELECT CURVE column. Either the blue, magenta, or brown curve can be selected.
4. Select the cylinder 1 to 5 that you wish to be measured.

To measure and compare the same cylinder after a period of operation, or when a malfunction is present. Using cylinder 2 as an example:

1. Carry out the tasks 1 to 3 above using the blue curve column and I2.
2. Select cylinder 2 to measure.
3. Select another field button (not chosen in point 1 such as I3) in the Indicate column.
4. Type in your identifying comments in the Indicate field.
5. Select I3 in Select Curve of the magenta column.
6. Select cylinder 2 to measure the combustion parameters of cylinder 2 again.

The following parameters are displayed in the numeric data display, at the instant when the cylinder indicator is taken, once a cylinder is selected together with the two indicate (I) buttons:

- |         |                                     |
|---------|-------------------------------------|
| Speed - | This is the engine speed (N).       |
| Index - | This is a measure of the fuel index |



- MIP - This is the Mean Indicated Pressure (MIP) measured in bar. This pressure is the equivalent pressure that acts on the piston throughout its vertical power stroke.
- IkW - This is the Indicated Power of the cylinder, and is calculated from
- $$MIP \times \text{volume of working piston} \times N$$
- T<sub>IGN</sub> - This is the timing of the ignition. The time between the T<sub>INJO</sub> and T<sub>IGN</sub> indicates the ignition delay present for that cycle. Increasing ignition delays will cause increased P<sub>MAX</sub> and large delta pressure/angle ( $\delta P/\delta \alpha$ )
- P<sub>MAX</sub> - This is the maximum pressure present during the working cycle. This will be affected by the quantity and timing of the fuel admission.
- T<sub>MAX</sub> - This is the position of the maximum temperature during the working cycle.
- P<sub>COMPR</sub> - This is the pressure due to compression alone after the compression stroke. It provides valuable information to the efficiency of the compression stroke, and the sealing efficiency of the piston rings, liner, and cylinder cover valves.
- P<sub>INJO</sub> - This is the fuel pressure when the fuel injector opens. It provides useful information that the fuel injector is correctly adjusted.
- P<sub>INJM</sub> - This is the maximum fuel pressure generated by the fuel pump. This indicates the internal sealing properties of the pump, and whether internal wear is present.
- T<sub>INJO</sub> - This is the timing of the fuel injection. The fuel pump timing will change when the VIT operation is selected on MD28, but it should be similar for all fuel pumps.
- L<sub>INJ</sub> - This is the length of the fuel injection period, and is dependant on the setting of the fuel control lever.

On the lower part of the diagram, the button Zoom can be used to zoom the diagram in horizontal direction to 300%. The button Spread is used to move overlaying curves apart vertically.





<This page is intentionally left blank>

00:04:32  
Running

Picture  
MD 121

### Cylinder Indication - Press/Vol

Alarms  
Silence

<p><b>GENERAL</b></p> <p>SPEED : 74.00 RPM              INDEX : 56.49 %              MIP : 15.94 BAR              IKW : 3648 KW</p> <p><b>COMBUSTION</b></p> <p>TIGN : 3.04 DGR              PMAX : 132.1 BAR              TMAX : 10.75 DGR              PCOMPR : 108.3 BAR</p> <p><b>INJECTION</b></p> <p>PINJO : 420.0 BAR              PINJM : 717.8 BAR              TINJO : -2.00 DGR              LINJ : 15.25 DGR</p>	
--	---

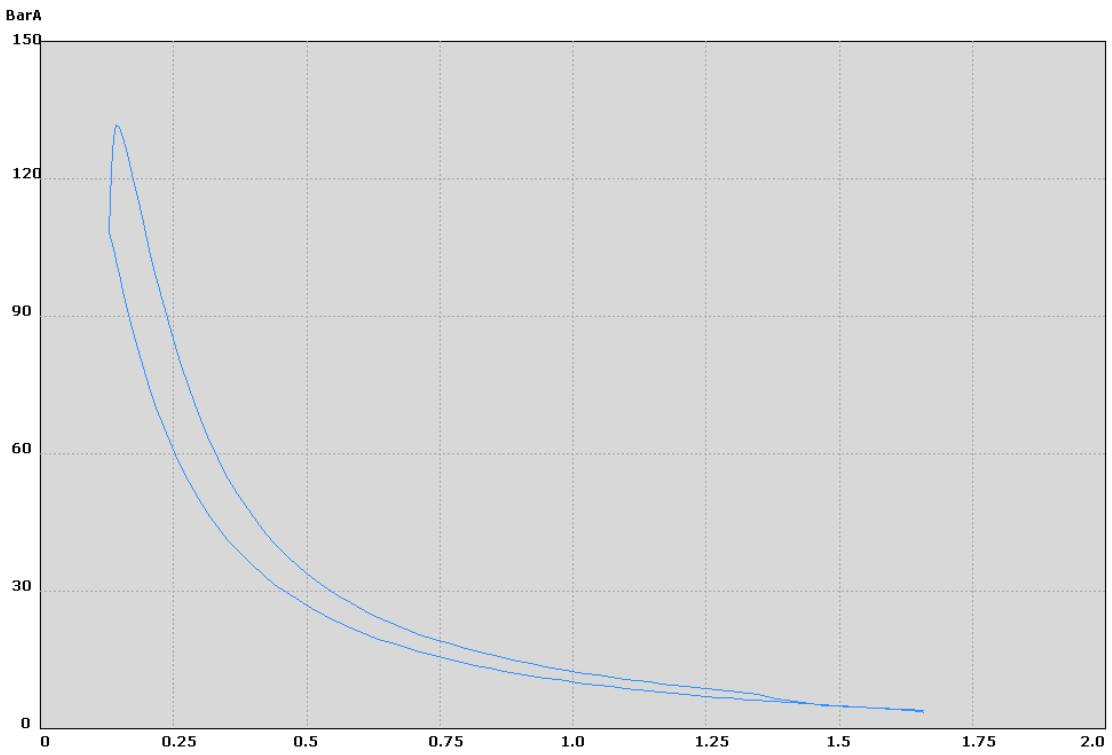
<p><b>GENERAL</b></p> <p>SPEED : 0.00 RPM              INDEX : 0.00 %              MIP : 0.00 BAR              IKW : 0.00 KW</p> <p><b>COMBUSTION</b></p> <p>TIGN : 0.00 DGR              PMAX : 0.00 BAR              TMAX : 0.00 DGR              PCOMPR : 0.00 BAR</p> <p><b>INJECTION</b></p> <p>PINJO : 0.00 BAR              PINJM : 0.00 BAR              TINJO : 0.00 DGR              LINJ : 0.00 DGR</p>	
--	--

<p><b>GENERAL</b></p> <p>SPEED : 0.00 RPM              INDEX : 0.00 %              MIP : 0.00 BAR              IKW : 0.00 KW</p> <p><b>COMBUSTION</b></p> <p>TIGN : 0.00 DGR              PMAX : 0.00 BAR              TMAX : 0.00 DGR              PCOMPR : 0.00 BAR</p> <p><b>INJECTION</b></p> <p>PINJO : 0.00 BAR              PINJM : 0.00 BAR              TINJO : 0.00 DGR              LINJ : 0.00 DGR</p>	
--	--

<p>INDICATE (Cyl. 1 - 5)</p> <table style="width: 100%; text-align: center;"> <tr><td>1</td><td>2</td><td>3</td><td>4</td><td>5</td></tr> <tr><td>12</td><td>13</td><td>14</td><td>15</td><td></td></tr> </table>	1	2	3	4	5	12	13	14	15		<p>SELECT CURVE</p> <table style="width: 100%; text-align: center;"> <tr><td>Cyl.1</td><td>11</td></tr> <tr><td>Cyl.2</td><td>12</td></tr> <tr><td>Cyl.3</td><td>13</td></tr> <tr><td>Cyl.4</td><td>14</td></tr> <tr><td>Cyl.5</td><td>15</td></tr> </table>	Cyl.1	11	Cyl.2	12	Cyl.3	13	Cyl.4	14	Cyl.5	15	<p>SELECT CURVE</p> <table style="width: 100%; text-align: center;"> <tr><td>Cyl.1</td><td>11</td></tr> <tr><td>Cyl.2</td><td>12</td></tr> <tr><td>Cyl.3</td><td>13</td></tr> <tr><td>Cyl.4</td><td>14</td></tr> <tr><td>Cyl.5</td><td>15</td></tr> </table>	Cyl.1	11	Cyl.2	12	Cyl.3	13	Cyl.4	14	Cyl.5	15	<p>SELECT CURVE</p> <table style="width: 100%; text-align: center;"> <tr><td>Cyl.1</td><td>11</td></tr> <tr><td>Cyl.2</td><td>12</td></tr> <tr><td>Cyl.3</td><td>13</td></tr> <tr><td>Cyl.4</td><td>14</td></tr> <tr><td>Cyl.5</td><td>15</td></tr> </table>	Cyl.1	11	Cyl.2	12	Cyl.3	13	Cyl.4	14	Cyl.5	15
1	2	3	4	5																																							
12	13	14	15																																								
Cyl.1	11																																										
Cyl.2	12																																										
Cyl.3	13																																										
Cyl.4	14																																										
Cyl.5	15																																										
Cyl.1	11																																										
Cyl.2	12																																										
Cyl.3	13																																										
Cyl.4	14																																										
Cyl.5	15																																										
Cyl.1	11																																										
Cyl.2	12																																										
Cyl.3	13																																										
Cyl.4	14																																										
Cyl.5	15																																										

ERS - MC90-V 2.2.9999.0353 (00)

Unit Conversion	Message Log			Process Directory	Panel Directory	Process Overview	Back	Forward
-----------------	-------------	--	--	-------------------	-----------------	------------------	------	---------



### 3.13.2 Press/Volume MD121

#### General

The pressure/volume diagram displays the classical p~V diagram used in thermodynamic calculations to measure the power produced within a cylinder.

The x –axis displays the swept volume of the piston.

The pressure/volume diagram would be used for:

- Display the classical power diagram, where the area within the diagram equates to the power developed by that power stroke.
- Display the maximum pressure
- Display the expansion curve and thus indicating whether there is slow burning fuel or afterburning of the cylinder combustion products present.

To enable the pressure indicator to measure the same procedure is required as for any of the cylinder indication screens. Once one screen has been activated, then ALL screens will indicate the same numerical information on the left side of the screen display, although the graphical information will change.

To enable the cylinder indicator to measure the combustion pressure, the following actions are required:

1. Select one of the field button (I1 to I5) in the INDICATE column
2. Type in your identifying comments in the INDICATE field to aid future fault identification.
3. Select the same field button (I1 to I5) in the SELECT CURVE column. Either the blue, magenta, or brown curve can be selected.
4. Select the cylinder 1 to 5 that you wish to be measured.

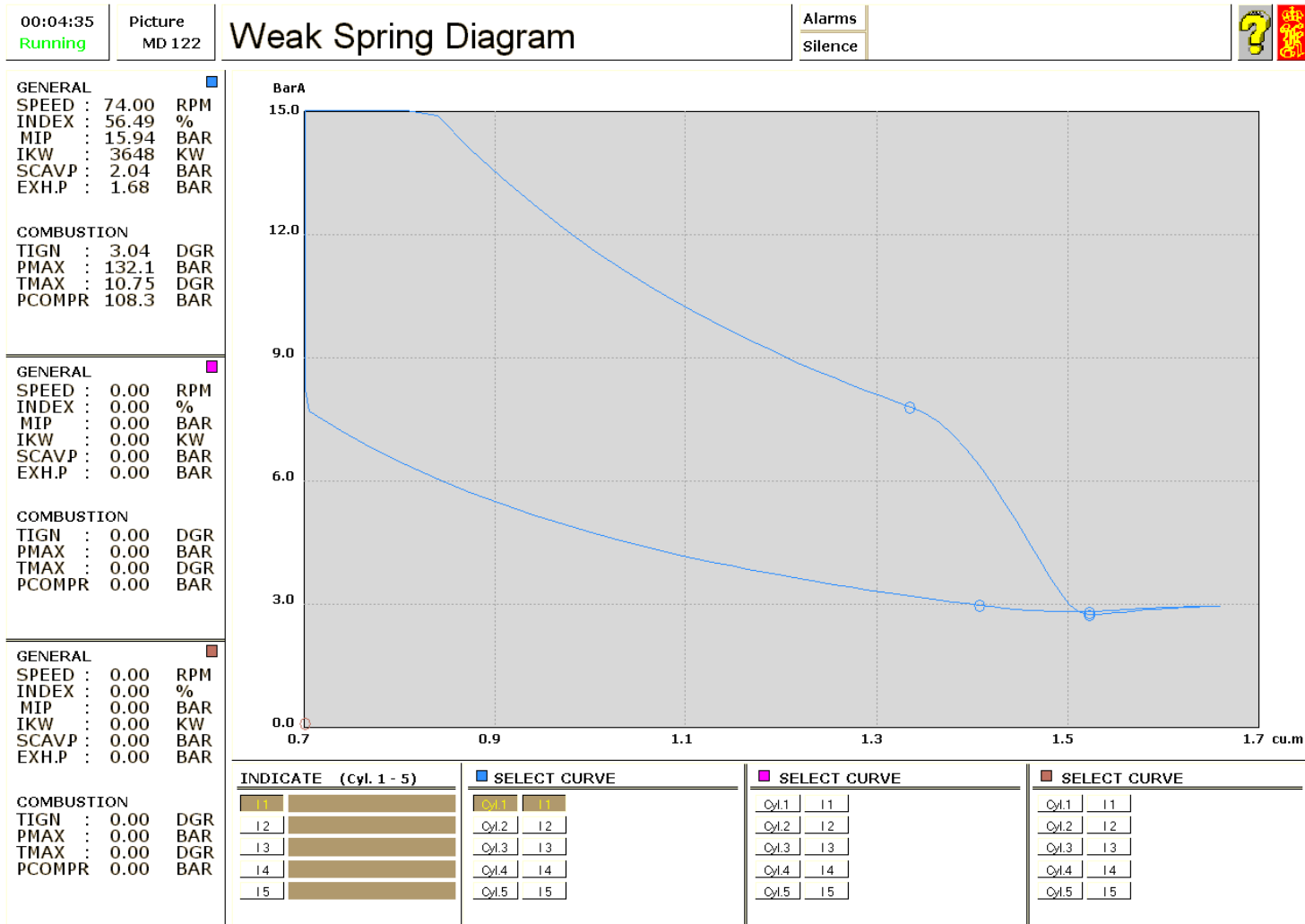

ERS - MC90-V 2.2.9999.0353 (00)

Unit Conversion	Message Log	Zoom 1	Zoom 2	Process Directory	Panel Directory	Process Overview	Back	Forward
-----------------	-------------	--------	--------	-------------------	-----------------	------------------	------	---------

### 3.13.3 Weak Spring diagram MD122

#### General

The weak spring diagram displays the scavenging process of the cylinder. The graphical display identifies the position of the opening of the exhaust valve, the opening and closing of the scavenge ports (same point before and after bottom dead centre), and the closing of the exhaust valve.

The weak spring diagram would be used for:

- Display the effects of fouled scavenge ports
- Display the effects of a leaking exhaust valve

*To improve the display two zoom buttons are present at the base of the screen.*

*Zoom 1 This enlarges the pressure scale from 0-15bar to 0-6 bar*



*Zoom 2 The enlarges the scale to 1.0 to 3.5 bar, and displays the actual pressure within the exhaust and scavenge manifolds as dotted horizontal lines.*

00:04:37  
Running

Picture MD 123

## Cyl Indication Delta-Press/Angle

Alarms  
Silence

**GENERAL**

SPEED : 74.00 RPM  
 INDEX : 56.49 %  
 MIP : 15.94 BAR  
 IKW : 3648 KW

**COMBUSTION**

TIGN : 3.04 DGR  
 PMAX : 132.1 BAR  
 TMAX : 10.75 DGR  
 PCOMPR 108.3 BAR

**INJECTION**

PINJO : 420.0 BAR  
 PINJM : 717.8 BAR  
 TINJO : -2.00 DGR  
 LINJ : 15.25 DGR

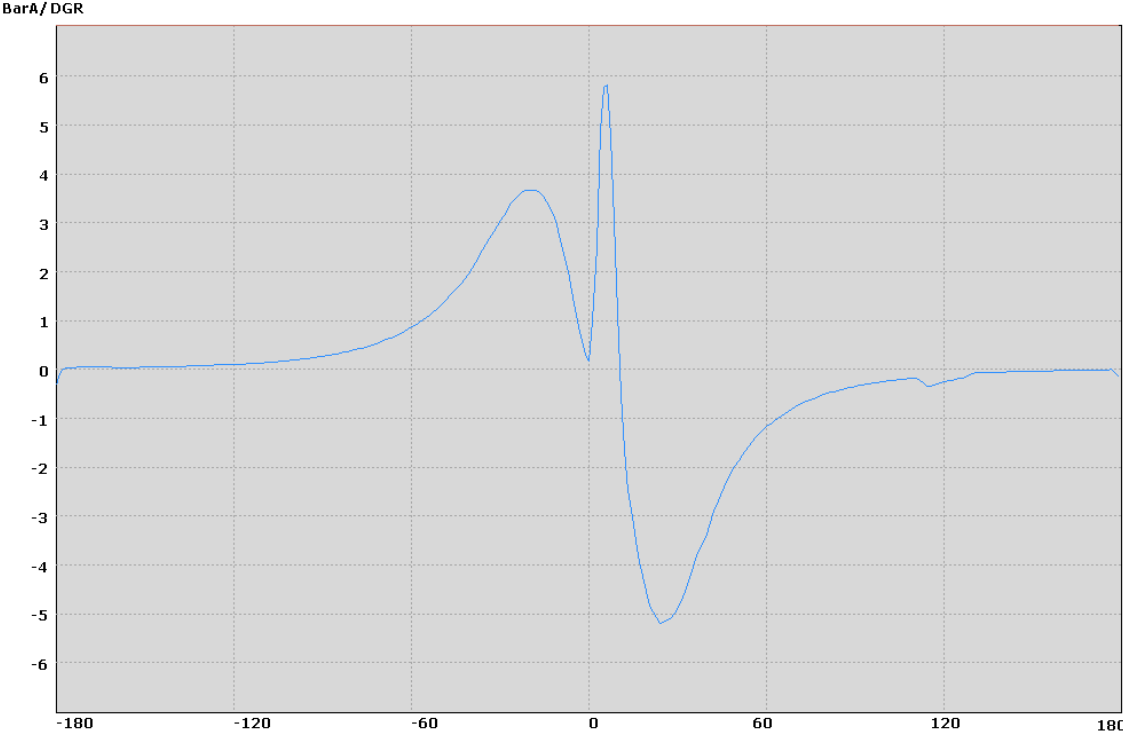

BarA/DGR

-180      -120      -60      0      60      120      180 Degr.

<b>GENERAL</b>	<b>SELECT CURVE</b>	<b>SELECT CURVE</b>	<b>SELECT CURVE</b>																														
<p>SPEED : 0.00 RPM            INDEX : 0.00 %            MIP : 0.00 BAR            IKW : 0.00 KW</p> <p><b>COMBUSTION</b></p> <p>TIGN : 0.00 DGR            PMAX : 0.00 BAR            TMAX : 0.00 DGR            PCOMPR 0.00 BAR</p> <p><b>INJECTION</b></p> <p>PINJO : 0.00 BAR            PINJM : 0.00 BAR            TINJO : 0.00 DGR            LINJ : 0.00 DGR</p>	<p><b>INDICATE &lt;Cyl. 1 - 5&gt;</b></p> <table border="1" style="width: 100%; border-collapse: collapse;"> <tr><td>1</td><td>11</td></tr> <tr><td>12</td><td></td></tr> <tr><td>13</td><td></td></tr> <tr><td>14</td><td></td></tr> <tr><td>15</td><td></td></tr> </table>	1	11	12		13		14		15		<table border="1" style="width: 100%; border-collapse: collapse;"> <tr><td>Cyl.1</td><td>11</td></tr> <tr><td>Cyl.2</td><td>12</td></tr> <tr><td>Cyl.3</td><td>13</td></tr> <tr><td>Cyl.4</td><td>14</td></tr> <tr><td>Cyl.5</td><td>15</td></tr> </table>	Cyl.1	11	Cyl.2	12	Cyl.3	13	Cyl.4	14	Cyl.5	15	<table border="1" style="width: 100%; border-collapse: collapse;"> <tr><td>Cyl.1</td><td>11</td></tr> <tr><td>Cyl.2</td><td>12</td></tr> <tr><td>Cyl.3</td><td>13</td></tr> <tr><td>Cyl.4</td><td>14</td></tr> <tr><td>Cyl.5</td><td>15</td></tr> </table>	Cyl.1	11	Cyl.2	12	Cyl.3	13	Cyl.4	14	Cyl.5	15
1	11																																
12																																	
13																																	
14																																	
15																																	
Cyl.1	11																																
Cyl.2	12																																
Cyl.3	13																																
Cyl.4	14																																
Cyl.5	15																																
Cyl.1	11																																
Cyl.2	12																																
Cyl.3	13																																
Cyl.4	14																																
Cyl.5	15																																

ERS - MC90-V 2.2.9999.0353 (00)

Unit Conversion	Message Log			Process Directory	Panel Directory	Process Overview	Back	Forward
-----------------	-------------	--	--	-------------------	-----------------	------------------	------	---------



---

### 3.13.4 Delta-Press/Angle MD123

#### General

The delta pressure / angle or pressure derivative graph is used to provide additional information about the combustion process by displaying the rate at which the pressure changes within the combustion chamber.

The delta pressure/angle diagram would be used for:

- Display the point when fuel ignition occurs
- Measure the maximum rate of pressure rise within the cylinder, to prevent shock loading damage to the piston rings and crosshead bearings.

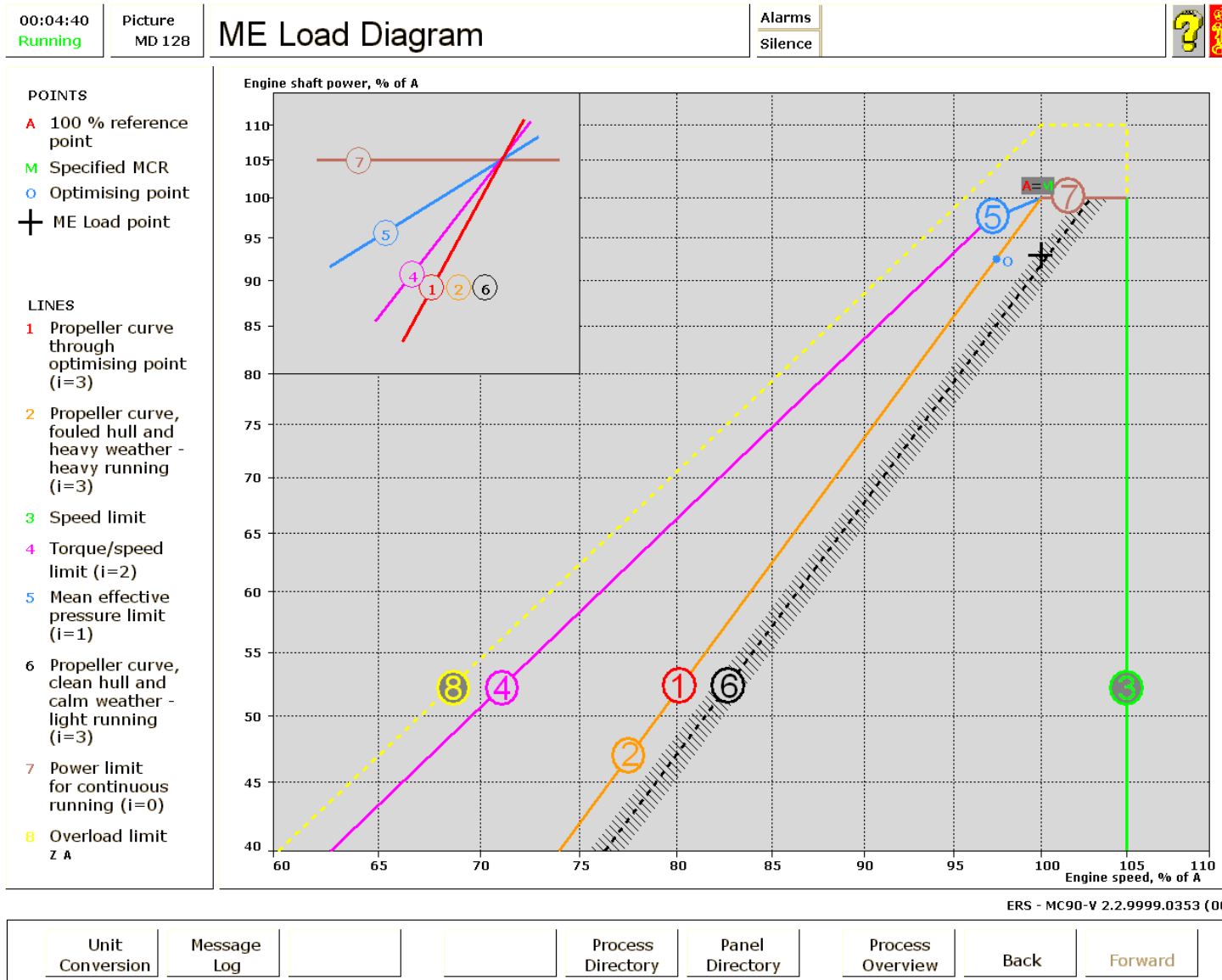



### 3.14 Load Diagram MD128

#### General

The load diagram is used to provide a graphical representation of the engine power and speed at any given time of the engine operation.

Logarithmic scales are used for both power and speed, so that the relationship  $P \propto N^3$  between them for a fixed pitch propeller installation can be shown as a straight line. The load diagram also provides valuable information about the limitations of engine operation. Normally the engine would be expected to operate within the limits of line 1-7 and 100% speed, but during shallow water operations, heavy weather, and during load-up periods, then operation within lines 4-5-7-3 are permissible.

These specific lines are:

Line 4 This represents the limit of thermal loading that should be placed on the engine. Should the engine operate to the left of this line, then there is insufficient air for combustion, and hence this will impose a limitation of the torque the engine can produce at a given speed.

Line 5 This represents the maximum mean effective pressure the engine can produce under continuous operation.

Line 7 This represents the maximum power the engine can produce under continuous conditions (100% of Maximum Continuous Rating (MCR))

Line 3 This represents the maximum acceptable speed under continuous operation (105% of the given speed for that engine)

Line 8. This represents an overload condition of the engine. The engine is designed to be able to operate for 1 hour in 12 between the lines 4 and 8, but in moderately heavy weather engine overload would easily occur when operating close to line 4 due the varying load imposed on the engine.

Within this normal operating range, the lines of 1, 2 and 6 represent the relationship of  $P \propto N^3$ , thus reflect the expected operation of the engine for various conditions.

Line 1 represents the expected operation of the engine with the shaft alternator operating. This line passes through the optimisation point of the propeller / engine set-up, where the maximum fuel efficiency of the engine will occur.

Line 2 represents the operation of the engine when the shaft alternator is not operating. This will reduce the power output of the engine, whilst it still delivers the expected speed.

Line 6 represents the light running operations of the engine. It is at this condition that the engine / propeller would be expected to operate at sea trials. However, once delivered the expected fouling of the hull, propeller and engine, combined with realistic weather and wind condition will dictate that for a given speed output a higher power output is required. By illustrating the original clean set-up of the engine, then the engineer can quickly see how much deterioration has occurred, and hence decide when cleaning of the hull, propeller and engine is required. Note that operation with



increasing hull fouling will cause the engine to operate in an overload condition, i.e. to the left of line 8.

The other points to note on this diagram are:

Point A – this represents the intersection between the expected operation line 6 and the maximum power line 7.

Point M – this represents the maximum continuous rating (MCR) of the engine as specified by the engine manufacturer, thus for this engine this will be 16MW at 74 rev/min.

The load diagram can be used to determine:

- When the engine is overloaded due to environmental conditions. Note this does not need to occur when the engine is developing excess power, as most damage occurs when operating to the left of line 8.

- The effectiveness of the load limiters. They should prevent operation to the left of line 4. If the engine was initially loaded on line 2 then when the engine is loaded up, the speed~power relationship will leave this line and move closer to line 4, especially if the shaft alternator is operating. The load limiter parameters must be adjusted if the engine load diagram indicates operation to the left of line 4 during load-up conditions. This will extend the time taken for the engine and vessel to speed up, but should prevent premature damage to the cylinder combustion components.

<This page is intentionally left blank>

00:08:07 Running	Picture MD 53	<b>Propeller Servo Oil System</b>	Alarms		
			Silence		

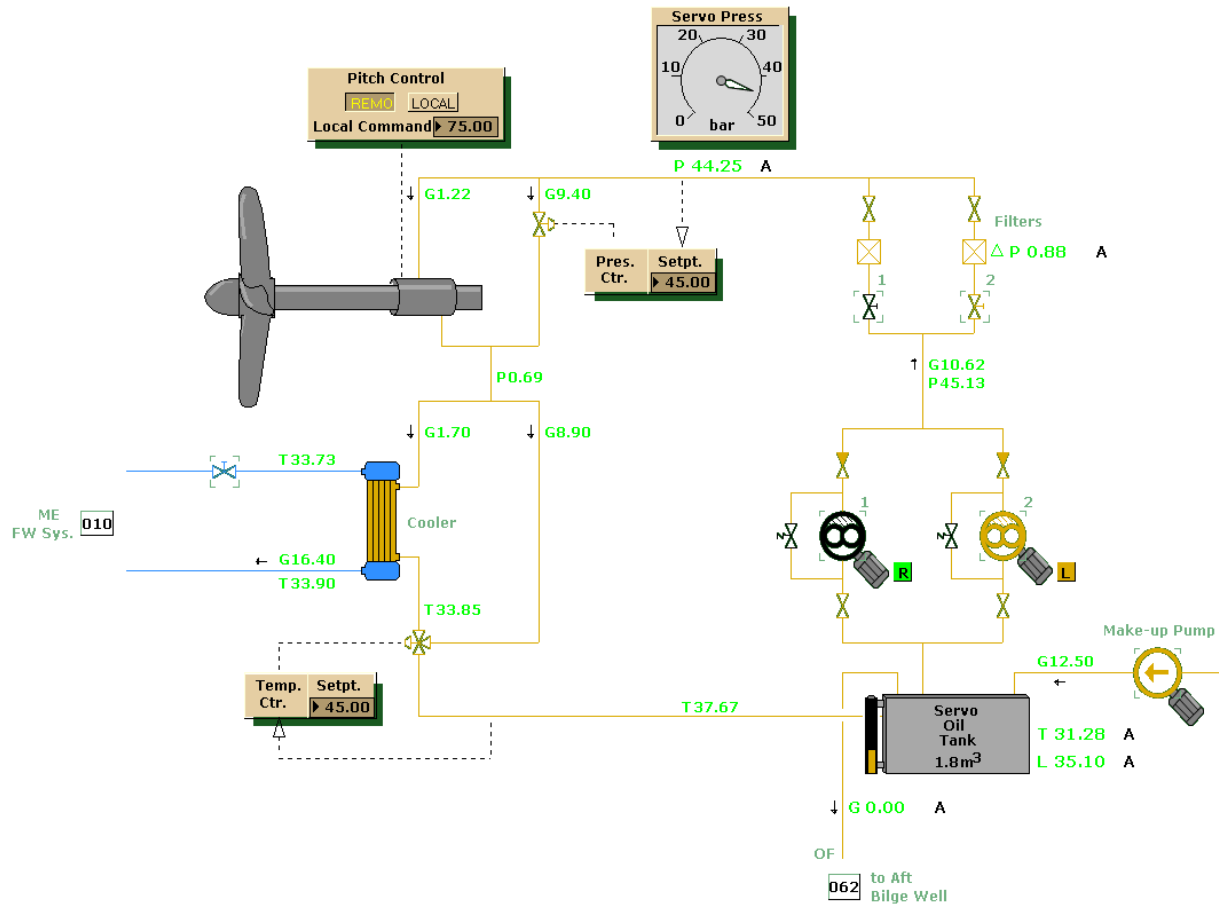

M

V

ERS - MC90-V 2.2.9999.0353 (00)

Unit Conversion	Message Log		Process Directory	Panel Directory	Process Overview	Back	Forward
-----------------	-------------	--	-------------------	-----------------	------------------	------	---------

## 4 PROPELLER AND STEERING GEAR SYSTEMS MD53

### 4.1 Propeller Servo Oil System MD53

#### General

The propeller pitch servo is operated by high-pressure hydraulic oil supplied by two electrically driven pumps. Usually only one pump is used with the other in stand-by mode.

The pitch control is dependent on hydraulic pressure. At low oil pressure, the maximum rate of pitch change is reduced correspondingly. If the oil is cold, the pitch servo acts more slowly.

#### Description

High pressure oil is delivered to the pitch servo. The pressure is controlled by bypassing oil through the pressure control valve, using a P-controller. Default pressure is 45 bar.

The return oil is cooled by LT fresh water and is controlled to be 45°C, again using a P-controller. The oil drains to the servo oil tank.

When pitch control is set to Local control, the pitch command is set in the numeric window in % of pitch range.

#### Operation procedure

##### 1. Starting procedure:

- 1.1 Main engine sea water system and LT fresh water system must be in service
- 1.2 Open fresh water inlet valve to servo lubricating oil cooler.
- 1.3 Open selected filter inlet valve.
- 1.4 Check level in Servo oil tank.
- 1.5 Select Local or Remote pitch control
- 1.6 Start the lubricating oil pump locally or from the PowerChief Pump Control panel
- 1.7 Put the lubricating oil pumps into AUTO mode from the Pump and Compressor Panel.

#### Model particulars

No comments.

00:01:51 Running	Picture MD 54	<b>Stern Tube System</b>	Alarms	
			Silence	

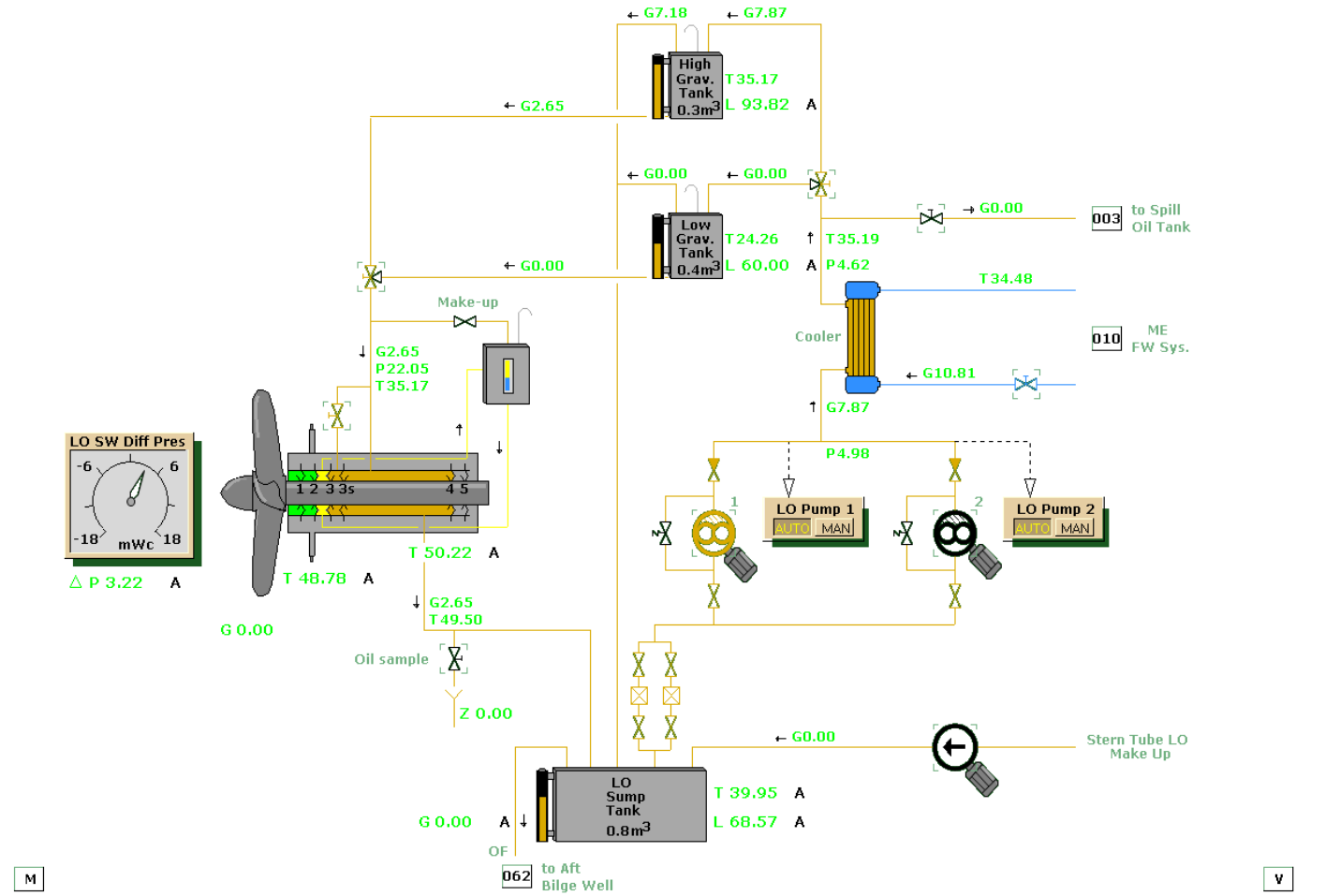

Unit Conversion	Message Log		Process Directory	Panel Directory	Process Overview	Back	Forward
-----------------	-------------	--	-------------------	-----------------	------------------	------	---------



## 4.2 Stern Tube System MD54

### General

The stern tube bearings are lubricated by two separate gravity LO tanks, one high and one low. These are selectable and should be chosen according to vessel draft.

### Description

The oil is pumped from the stern tube sump tank to the selected gravity tank, from where it flows to the stern tube bearings and also to the stern seal.

The gravity tank is automatically filled by one of the lubricating oil pumps and surplus oil is continuously drained to the sump tank through an overflow pipe.

The oil is cooled as it is pumped to the gravity tank. The heat exchanger is LT fresh water cooled.

If the running pump fails to maintain the level in the gravity tank the stand by pump will start at low level in the gravity tank provided that the pump is in Auto mode. The low-level limit can be adjusted from the variable page.

Stopping of pumps has to be carried out manually.

Refilling of the lubricating oil sump tank is carried out by starting the make-up pump.

The oil can be transferred to the spill oil tank in case of contamination. Water contamination can be drained through the sample cock.

The stern tube has a fwd seal oil system that can be topped up from the gravity feed line.

### Operation procedure

- 1.1 Ensure cooling water to Stern Tube cooler.
- 1.2 Refill lubricating oil sump tank if necessary.
- 1.3 Select required gravity tank using 3-way valve in filling line.
- 1.4 Select correct gravity feed to stern tube.
- 1.5 Ensure stern seal isolating valve is open.
- 1.6 Start the lubricating oil pump in manual.
- 1.7 When one pump is started, set the other pump in Auto.
- 1.8 If the running pump is unable to maintain the level in the gravity tank, the stand-by pump starts automatically.
- 1.9 Check level of oil in sealing tank, fill from make-up valve.  
Drain water if required.
- 1.10 Stop of pumps to be carried out manually

### Model particulars

No comment.

00:02:02 Running	Picture MD 58	<b>Steering Gear System</b>	Alarms	
			Silence	

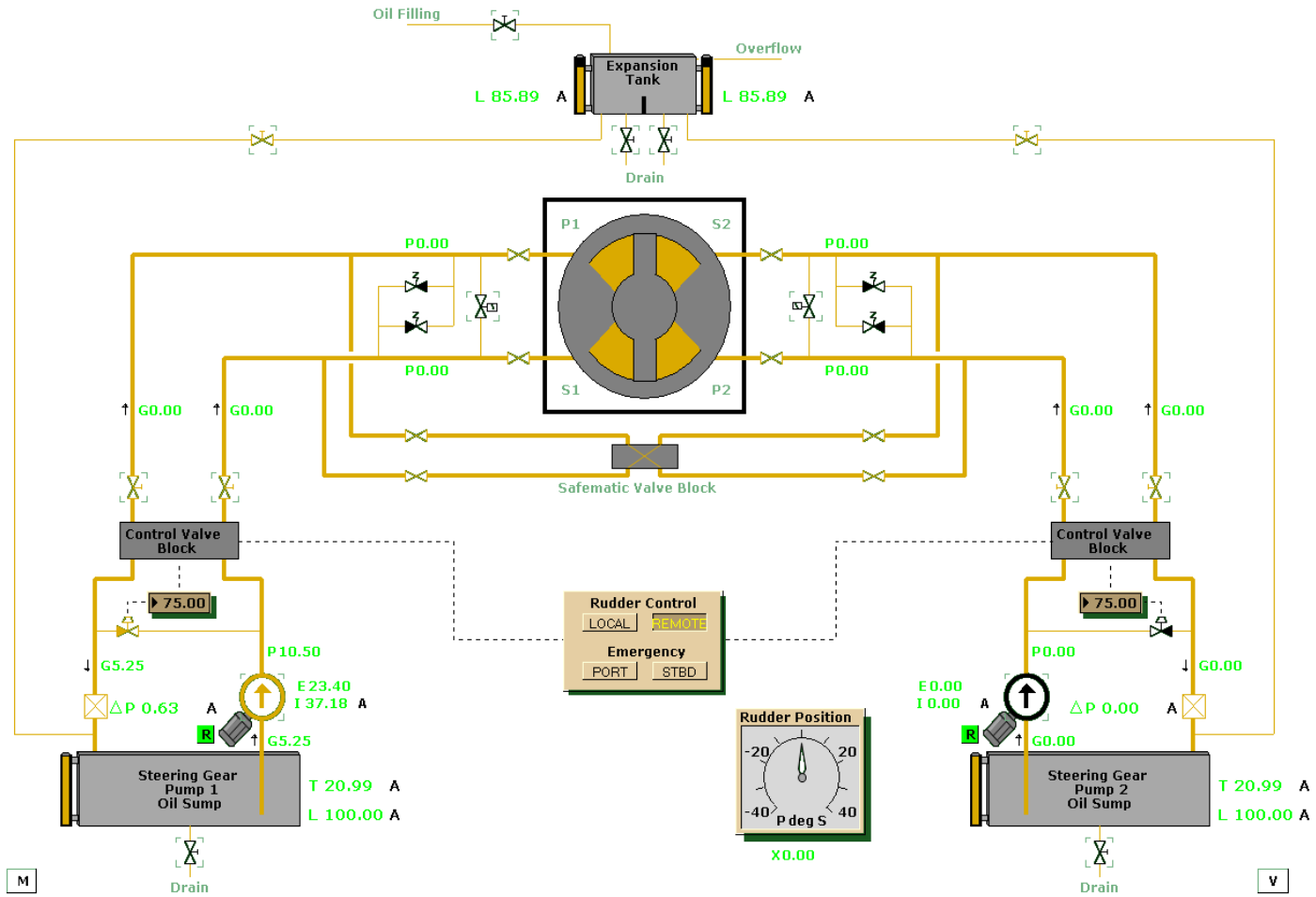

ERS - MC90-V 2.2.9999.0353 (00)

Unit Conversion	Message Log		Process Directory	Panel Directory	Process Overview	Back	Forward
-----------------	-------------	--	-------------------	-----------------	------------------	------	---------



### 4.3 Steering Gear System MD58

#### General

##### The steering gear system comprises:

- one hydraulic steering gear of the rotary vane type,
- two identical hydraulic systems. Each system includes:
  - one steering gear pump Unit
  - one control valve block assembly
  - necessary measuring, indication and alarm facilities for pressure, temperature, level and flow
  - necessary control and safety equipment
- one expansion tank common to both hydraulic systems
- emergency steering control equipment
- rudder angle indication

The steering gear is able to change the rudder position from 35 deg. to –30 within 48 sec. with one pump and 24 sec. with two pumps, independent of ship speed. The increased demand of thrust on the rudder at higher ship speed is taken care of by increased pump pressure.

The steering gear system is of the “IMO model” with the functionality required according to Classification Societies for gas carriers and oil tankers above 100000 tons.

#### Hydraulic system description

The steering gear itself is operated by two open type, low pressure hydraulic systems.

Each hydraulic system is supplied from a steering gear pump Unit (Power Pack) comprising:

- oil tank with a bottom drain valve
- steering gear pump of the fixed displacement type
- return line oil filter
- level indication
- equipment for monitoring of temperature, pressure and level

Additionally each system is equipped with:

- One adjustable system pressure-relief control valve controlling the maximum discharge pressure from the steering gear pump. Default setting is 75 bar. Above this pressure, the hydraulic oil will be by-passed back to the oil suction tank.
- one shock-relief control valve block with two adjustable relief control valves protecting the steering gear and the hydraulic system against pressure shocks when braking the rudder movement
- stop valves for manual isolating of the system
- one manual operated stop valve for by-pass of the pressure-relief shock valves

The oil tank is connected to the bottom of the expansion tank, common to both hydraulic systems and normally the oil tank is full (100% level).



Each system is provided with the following alarms and safety functions:

- **LOW LEVEL - STEERING GEAR UNIT TANK**
- **LOW LEVEL STOP - STEERING GEAR PUMP**
- **OIL FILTER HIGH DIFFERENTIAL PRESSURE**
- **HIGH OIL TEMPERATURE**

Steering gear pump no 1 and the belonging controls are supplied from bus bar 1.

Steering gear pump no 2 and the belonging controls are supplied from Emergency bus bar.

Emergency steering may be carried out, in case of system communication failure with the bridge.

### **Control system description**

The steering gear control system is of the on-off type (3-point control). The electrical controlled directional-control valve integrated in each of the control valve blocks controls the rudder angle. The control valve block also includes over centre and flow control valves, necessary for mechanical and hydraulic safety and control.

#### **Normal control** (Follow up control)

The directional-control valve receives its control signals from the automatic rudder control system, having its set point either from the auto pilot or from the manual rudder control located both locally and at the bridge steering console

At deviations between the actual rudder position and the desired rudder position, a port or starboard signal is given to the electrical directional-control valve. The control valve changes its position and hydraulic oil is led in or out of the respective chambers at the steering gear, shifting the rudder angle towards the desired position as long as the deviation exists.

#### **Emergency control** (Non follow up control)

The directional-control valve can be manually controlled by means of the emergency control buttons fitted both at the bridge steering console and locally at the control valve.

#### **Automatic separation control system (Safematic system)**

According to international regulations, the steering gear system of larger ships must be provided with automatic separation of the two hydraulic systems, in case of a large oil leakage at one of the systems.

Both steering gear systems are connected to the common expansion tank.

A major oil leak at one of the systems will lead to a decrease of the oil level in the expansion tank and a “LOW LEVEL ALARM - EXPANSION TANK” is activated.

If the oil level continues to decrease both steering gear pumps receive a START command resulting in a start of the stand by steering gear pump and shifts the safematic control valve block into a position where the two systems are separated from each other



If the expansion tank oil level is still decreasing it will reach the level where the expansion tank is split up into two chambers by an internal partition plate. Each steering gear system is now supplied from its own expansion tank chamber and the decrease in oil level will only take place in the chamber connected to the defective system. A low level switch in the chamber in question stops the respective steering gear pump and opens the by-pass valve to prevent hydraulic lock - the steering gear chambers connected to the defective system are by-passed (short-circuited)

**NOTE**

In this condition, the steering gear torque is reduced and the ship's speed must immediately be reduced to 7 knot and the rudder angle must not exceed 15°.

The separation system can be tested by draining the expansion tank.

The systems can also be separated manually by means of the safematic valve block and the by-pass valves.



## Operation procedure

### 1. Preparation

- 1.1 Check content in hydraulic oil tanks, refill if necessary.
- 1.2 Check that steering gear and expansion tank shut off valves are open.
- 1.3 Check that Safematic valve block valve is open.
- 1.4 Start steering gear pump(s) locally or remotely from control room or bridge.

Testing of steering gear should be carried out before leaving port. This is normally carried out from the bridge.

### 2. Pumps

- 2.1 During normal operation at sea only one pump is in operation
- 2.2 During manoeuvre and in congested waters two pumps must be in operation.
- 2.3 Starting and stopping of the pumps can be carried out locally or remote via the Power Chief - Pump Control system or from the bridge steering consoles.

### 3. Drain and oil filling

- 3.1 Oil and water drainage from the steering gear systems can take place from:
  - The bottom of each chamber in the common expansion tank
  - The bottom of each steering gear pump unit tank
- 3.2 Oil filling is done via the filling valve fitted at the expansion tank.

### 4. Rudder commands

- 4.1 Rudder command can be set manually on the autopilot.
- 4.2 To set specific rudder commands, select MAN and enter numeric values in %.
- 4.3 Autopilot can be set to specified course commands at bridge steering console.
- 4.4 Select ON and enter course.
- 4.5 Servo speed is dependent on servo oil pressure.
- 4.6 In bad weather, two pumps can be run to obtain quicker servo response to auto pilot.
- 4.7 To use the emergency steering select OFF on the autopilot.
- 4.8 Emergency control can be operated locally or from the bridge console. Note that the emergency control is non-follow up and the steering gear will turn as long as the button is depressed.

Note that if a failure of automatic control of by-pass and safematic valves should occur, these valves have to be operated locally.



### Model particulars

For studies of mutual influence between the steering gear and autopilot the autopilot is made available in the mimic diagram 58.

When the leakage fault is identified and “repaired”, the valves have to be manually put back to normal position.

Rudder command can be set manually on AUTO PILOT to study effects of sudden large variations on rudder.

Servo speed is dependent on servo oil pressure.

As long as the directional-control valve is activated the discharge pressure is a function of the pressure drop in the control valves and system piping and at the rudder torque and the maximum pressure

is limited by the set point of the pressure-relief control valve. When the directional-control valve is **not** activated, the system pressure-relief control valve is relieved and the pump pressure decreases to a very low value (5-10 bar - caused by the very short piping around the pump unit and the return line filter).

If the rudder command causes the rudder angle to shift to one of the extreme positions, the steering gear vane is limited by the steering gear body at 35° and the pressure will increase to set point of system pressure-relief control valve (normally 75 bar).

If this condition remains for a prolonged period, the oil temperature will rise. At temperature level above approx. 65°C decomposing of the oil and pump wear will increase exponentially and end with a break down of the pump.

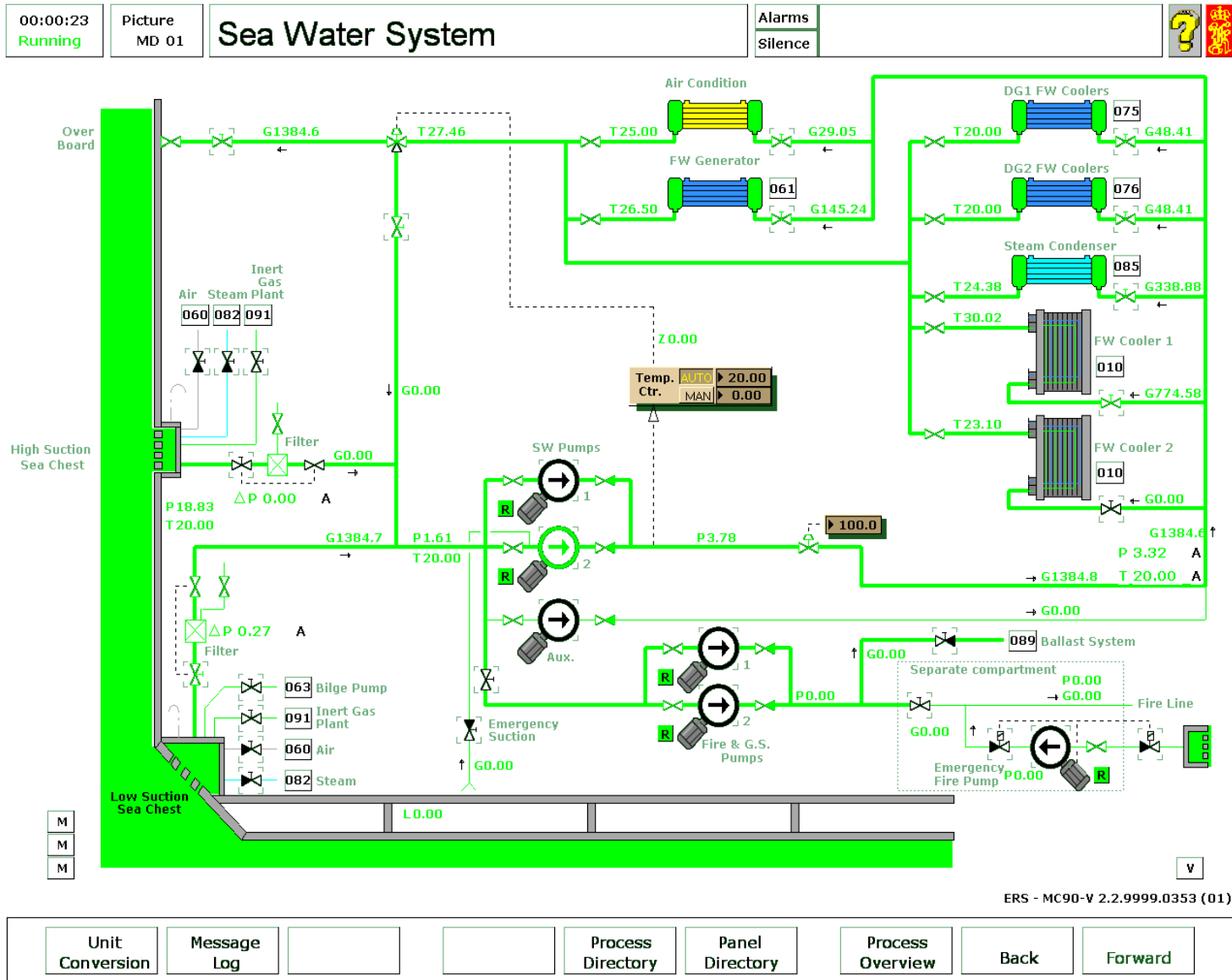

## 5 SERVICE SYSTEMS

### 5.1 Main Sea Water System MD01

#### General

Sea water is pumped by two electrically driven SW pumps from sea chests through the sea water filter. The flow from the pumps goes to seven coolers, which are connected in parallel:

- Fresh Water Cooler 1
- Fresh Water Cooler 2
- Steam Condenser
- DG1 Fresh water cooler
- DG2 Fresh water cooler
- Fresh Water Generator
- Air Conditioning

In port when the cooling requirement is low, an auxiliary pump is fitted. During cargo operations a main pump may be required.

#### Description

Sea water is taken from either a high suction sea chest via a strainer when the vessel is loaded or a low suction sea chest when the vessel is in ballast.

In order to avoid too low sea water temperatures at the cooler inlets a controllable recirculation valve is used to circulate water from the overboard line back to the common sea water suction line.

The recirculation valve is controlled by a standard PID controller. The recirculation line is smaller and has higher flow resistance than

the overboard line. The total sea water flow will therefore be reduced in the recirculation line.

The control valve has a pneumatic actuator.

The standard valve actuator can be changed with a motor driven actuator. The motor control interface is modelled as follows:

- 100 % controller signal gives full opening speed
- 50 % controller signal gives zero speed
- 0 % controller signal gives full closing speed

Studies comparing the dynamic behaviour of the standard actuator system with the motor actuator system are recommended.

A model variable page, MVP7030, is for testing of frequency control of pumps. The main SW, HTFW and LTFW pumps are connected to a frequency converter, if activated. The frequency can be adjusted from 40 to 60 Hz. The total electric power from converter to pumps is displayed for convenient economy studies at reduced ME load etc.

Two fire and general service pumps are provided which can service the fire main or the ballast system. They take suction from the main sea water service pump suction line

No 2 main SW pump can be used in the event of serious flooding. A separate pipe to the tank top is provided for this operation. Flooding indication and level are given.



The emergency fire pump has a separate suction from its own sea chest.

**1. Operation Procedure**

- 1.1. Open relevant sea suction valves
- 1.2. Open pump outlet and inlet valves
- 1.3. Open valves to relevant coolers. Under normal circumstances only one fresh water cooler need be in use
- 1.4. Set controller for recirculation valve to auto and 20<sup>0</sup>C
- 1.5. Start one sea water pump locally
- 1.6. Put one pump in auto mode from pump/compressor control panel (MD102). Normally one pump running one in standby.

**2. ER Flooding**

- 2.1. Ensure No2 pump is running
- 2.2. Open Emergency suction valve
- 2.3. Close Both sea chests valves
- 2.4. Ensure that temperature control valve is in full overboard position



<This page is intentionally left blank>

00:01:40 Running	Picture MD 40	<b>Air Ventilation System</b>	Alarms	 
			Silence	

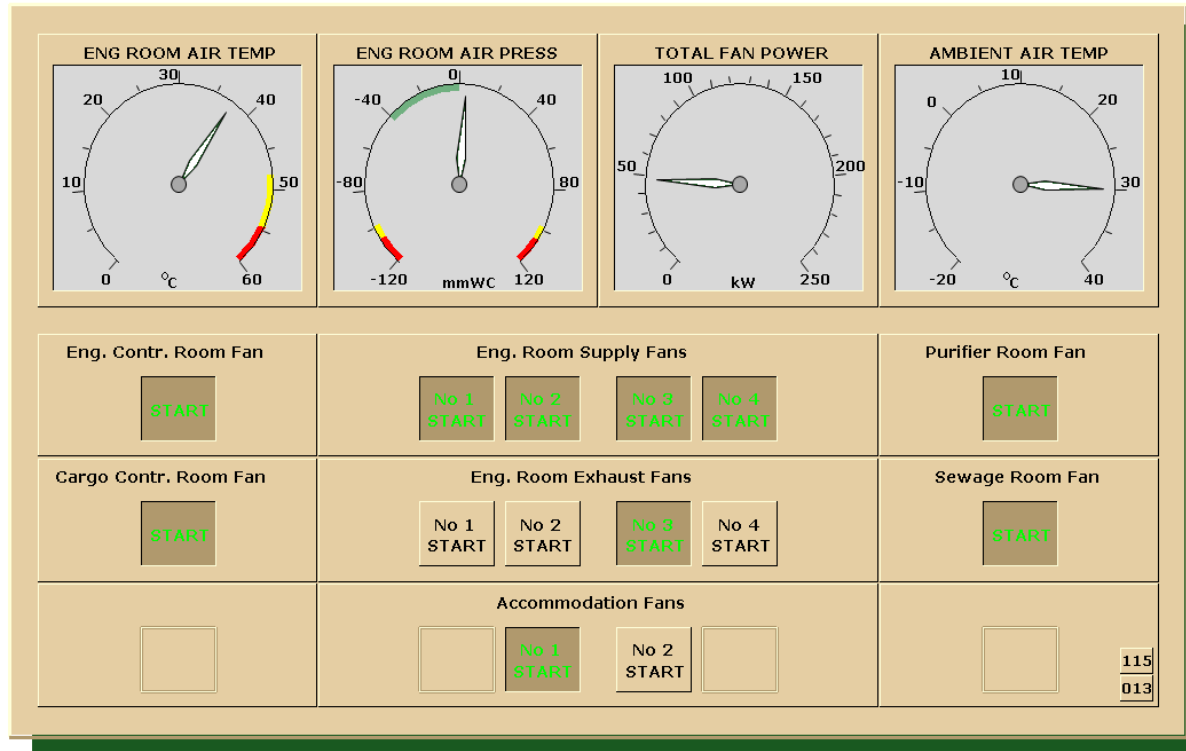

ER Press P3.75 A  
 ER Temp T37.62 A  
 ECR Temp T24.15 A

114 Fire Extinguish  
 115 Z A  
 001 Z A

M

V 104

ERS - MC90-V 2.2.9999.0353 (01)

Unit Conversion	Message Log			Process Directory	Panel Directory	Process Overview	Back	Forward
-----------------	-------------	--	--	-------------------	-----------------	------------------	------	---------



## 5.2 Air Ventilation System MD40

### General

The ventilation system consists of four supply fans and four extractor fans for the main engine room. Control room and Cargo Control room all have supply fans. The Purifier room and Sewage room have exhaust fans. Accommodation fans are also started from this panel.

The panel gives indication of Engine Room and ambient temperature as well as air pressure within the Engine room.

The air pressure in the engine room space will vary depending on which fans are running and also on whether the main engine and generators are running.

Insufficient air supply will lead to the engine room temperature rising.

Indication is also given of fire detection in the Engine room and Deck areas.

Should the Emergency Shut Off be operated or the CO<sub>2</sub> cabinet door be opened then the Engine room supply and exhaust fans will be stopped.

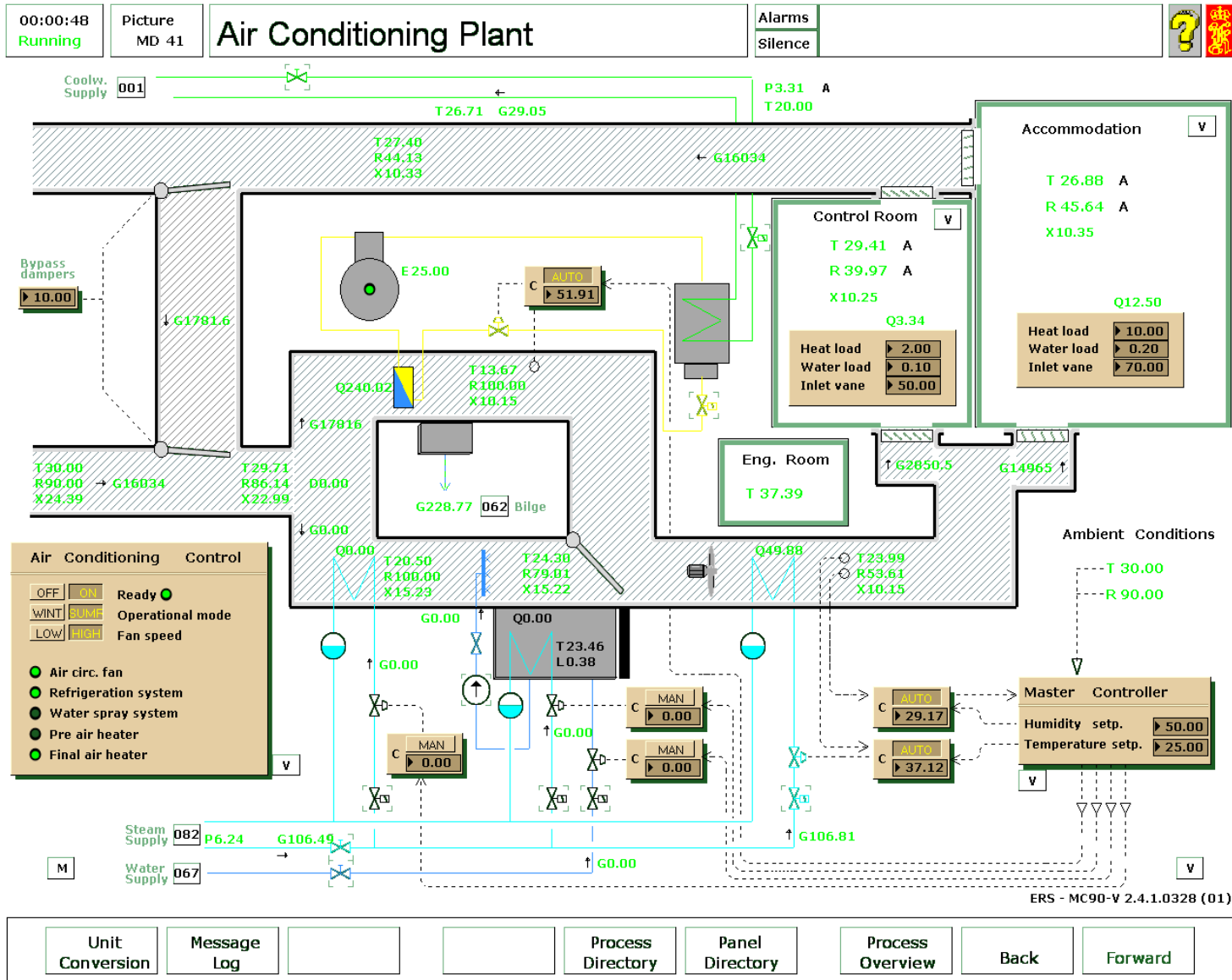

## 5.3 Air Conditioning Plant MD41

### Introduction

The air is supplied to the accommodation and the engine control room by an air handling unit (AHU) located in the air conditioning unit room situated in the accommodation block on the starboard side of the upper deck (accessed from the engine room).

The AHU consists of an electrically driven fan drawing air through the following sections from inlet to outlet:

- One air filter
- One steam preheating unit
- A humidifier section
- One steam final heat section
- One air cooler evaporator coil
- A water eliminator section
- A fan section
- A discharge section

Humidification of the air is arranged with automatic control and this is fitted at the outlet part of the AHU.

The air is forced into the distribution ducting, which supplies the accommodation and the engine control room.

The system is designed for fresh air with heat recovery by means of two bypass dampers using a part of the heat in the outgoing stale air.

Cooling is provided by a direct expansion R134a system. The plant is automatic and consists of one compressor/condenser units supplying the evaporators contained in the accommodation air handling unit. The expansion valve for the coil is fed with liquid refrigerant from the air conditioning compressor, the refrigerant having been compressed in the compressor then cooled in the

condenser where it is condensed to a liquid. The liquid R134a is then fed, via dryer units, to the evaporator coils where it expands under the control of the expansion valves, before being returned to the compressor as a gas. In the evaporator coil, it extracts heat from the air passing over the coils.

Air is circulated through ducting to outlets in the cabins and public rooms.

The plant is controlled by a master controller where it is possible to set the set point for humidity and temperature before the inlet to the accommodation and ECR.

Summer or winter operation may be selected on the air conditioning panel in the engine room.

The bypass dampers allow recirculation of the air if the ship is in poor ambient conditions i.e. in harbour with a sandstorm.

Normally the bypass dampers must only be opened 30% to reduce the recirculation of bad air spreading such things as colds etc. through the vessels personnel.

### 1 Winter operating procedure:

- 1.1 Prepare and start the steam supply for the pre- and final heating section in AUTO mode.
- 1.2 Prepare and start the water supply for the humidifier section in AUTO mode.
- 1.3 Set the bypass damper at 10%.
- 1.4 Start the plant in winter mode with low fan speed.
- 1.5 Set the master controllers set points at the wanted values.
- 1.6 Control the plant with appropriate intervals and adjust the plant if necessary.



**2. Summer operating procedure:**

- 2.1 Prepare and start the steam supply for the final heating section in AUTO mode.
- 2.2 Prepare and start the water supply for the condenser.
- 2.3 Set the bypass damper at 10%.
- 2.4 Start the plant in summer mode with low fan speed.
- 2.5 Set the master controllers set points at the wanted values.
- 2.6 Control the plant with appropriate intervals and adjust the plant if necessary.

**Note:**

It is possible to adjust the capacity of the plant by opening/closing the bypass damper and/or low/high speed of the fan.

**Note:**

Steam valve V15605 and water valve V15606 must be open for starting the plant.

**Note:**

Pressing the MAN buttons on the controllers, they will change to AUTO mode and visa versa.

The compressor starts when pressing the ON button on the control panel.

- ).

<This page is intentionally left blank>

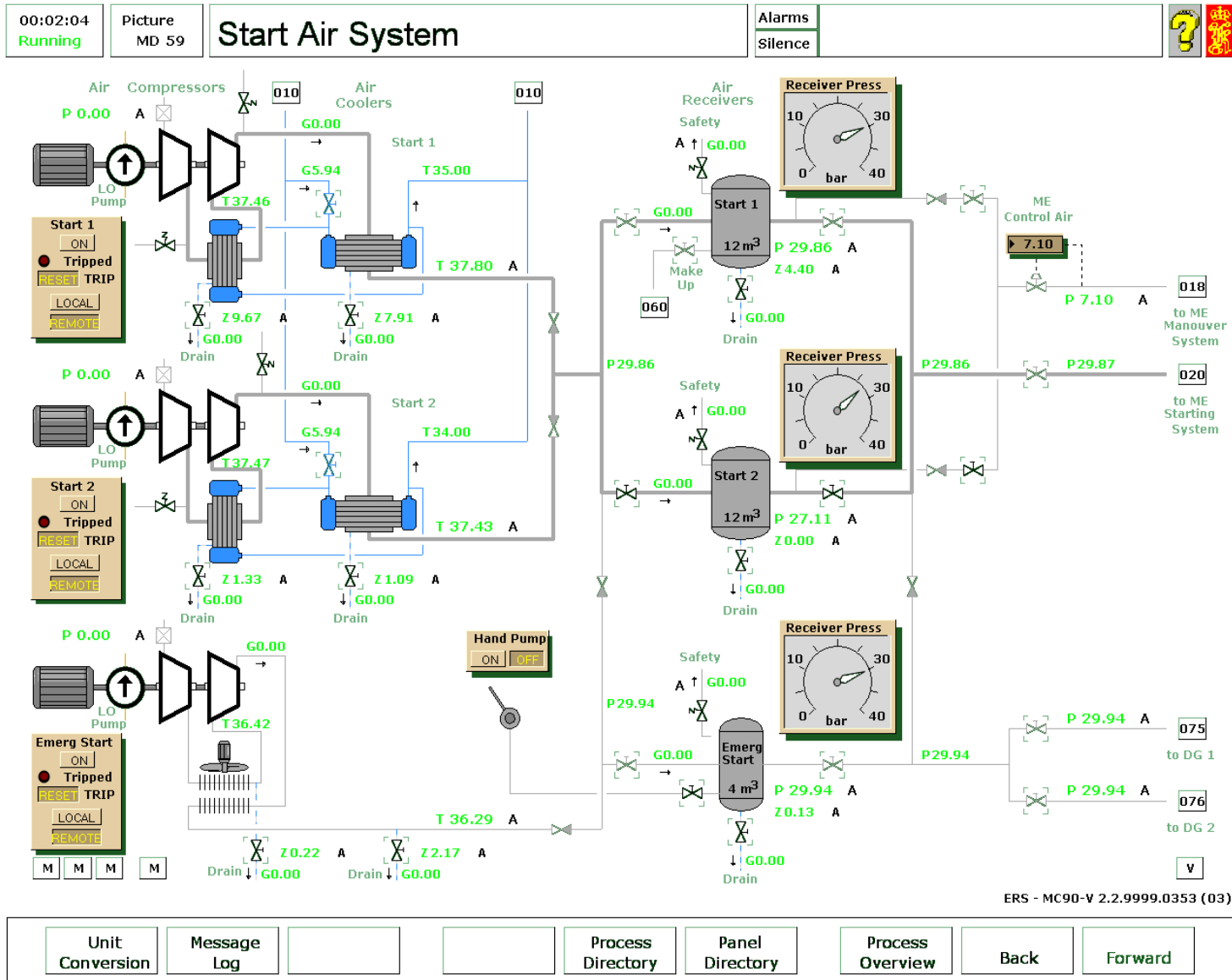



## 5.4 Starting Air Compressors MD59

### General

The purpose of the start air is to provide starting air to the diesel engines and ensure that first start is available should all power to the vessel be lost.

The compressed air system consists of two start air compressors, one emergency air compressor and one hand pump, two start air receivers and one emergency start air receiver.

All compressors start and stop automatically according to need by the compressor control system included in the PowerChief system if the compressor is in AUTO position. The emergency compressor is supplied from the emergency switchboard

### Description

Each air compressor is monitored by an independent, local safety system.

The air compressors will trip at:

	Start air comp.	Emergency air comp.
Disch. air temp.	> 110°C	> 110°C
Lub oil press.	< 0.75 bar	< 0.75 bar

The Start air compressors are cooled by LTFW, the Emergency compressor is air cooled. Trip condition is indicated by a red alarm light on the compressor panel.

The starting air compressors are normally operated with one compressor selected as Master. This is achieved at the Power Chief panel. Master cut in and cut out setting can be set on variable page 7020.

The start air receivers can be operated in parallel, or one of the receivers can be pressurised and shut off to be kept as a standby receiver. The main and the auxiliary diesel engines are supplied by separate air lines and stop valves from one or both of the air receivers. There is a non return valve in the connection from the main start air to the auxiliary start air to ensure that the emergency start air receiver only supplies the auxiliary engines. The main air receivers supply control air for the main engine via a reducing valve.

The safety valves for the start air receivers open at approximately 32 bar. The settings of the safety valves can be changed from the variable page.

The air receivers and the air coolers will gradually fill with water, depending on compressed air production and air humidity. The receivers and coolers must be manually drained regularly. Much water in the start air receivers will reduce starting capacity.

If the service air compressor fails, make-up air can be taken from the #1 start air receiver.

## Operation procedure

### 1. First Start

- 1.1.If no electrical power is available, open discharge valve of hand pump and fill emergency receiver using the hand pump.
- 1.2.If the emergency generator is available the emergency compressor can be used
- 1.3.Open Emergency Air receiver inlet valve, start the Emergency compressor

### 2. Preparations before starting start air compressors after a longer period out of operation.

- 2.1.Check that main sea water system and LT fresh water system are operation and that the valve to air compressor coolers is open.
- 2.2.Open fresh water inlet valve(s) to start air cooler(s).
- 2.3.Open drain valve(s) from start air cooler(s).
- 2.4.Open air inlet valve(s) to start air receiver(s).
- 2.5.Open air outlet valve(s) from start air receiver(s).
- 2.6.Operate drain valve(s) from start air receiver(s) to ensure no water is present.

### 3. Starting procedure

- 3.1.If the selected compressor is tripped (TRIPPED lamp lit), press RESET button on the compressor panel. Start the compressor by pressing button ON.
- 3.2.Close drain valves.
- 3.3.Select AUTO mode on the PowerChief panel. Select the desired Master compressor. The compressors will then start and

stop according to the limits given. These limits are adjustable from the variable page 7020.

**Note:** When a compressor is started manually it is not stopped automatically by a pressure control.

- 3.4.When pressure in air vessel increases open air supply valve(s) to selected consumer(s).

### 4. Normal operation

- 4.1.Normally all start air vessels are pressurised and in operation.
- 4.2.Both of the start air compressors are in AUTO mode with one selected as Master.
- 4.3.Emergency start air compressor in manual mode with emergency air receiver supplied from main compressors.
- 4.4.Air receivers and air coolers must be drained regularly.

### Model particulars

- The basic start air leakage is set to give 2-3 compressor starts per hour. The air flow delivered from the start air or emergency air compressor is dependent on the discharge (receiver) pressure.
- The start air consumed during a main engine start depends on start duration and engine speed. The diesel generators draw an equal amount of air for each start.
- All main control valves included in the ship machinery are assumed to be air operated. As the control air pressure is reduced, these devices will be slower and the effective actuator time constants are increased. Various control loop problems may develop at low control pressure. Some of the loops will be slow and stable, others conditionally unstable (unstable in an intermediate range).

<This page is intentionally left blank>

00:02:17 Running	Picture MD 60	<b>Service Air System</b>	Alarms	
			Silence	

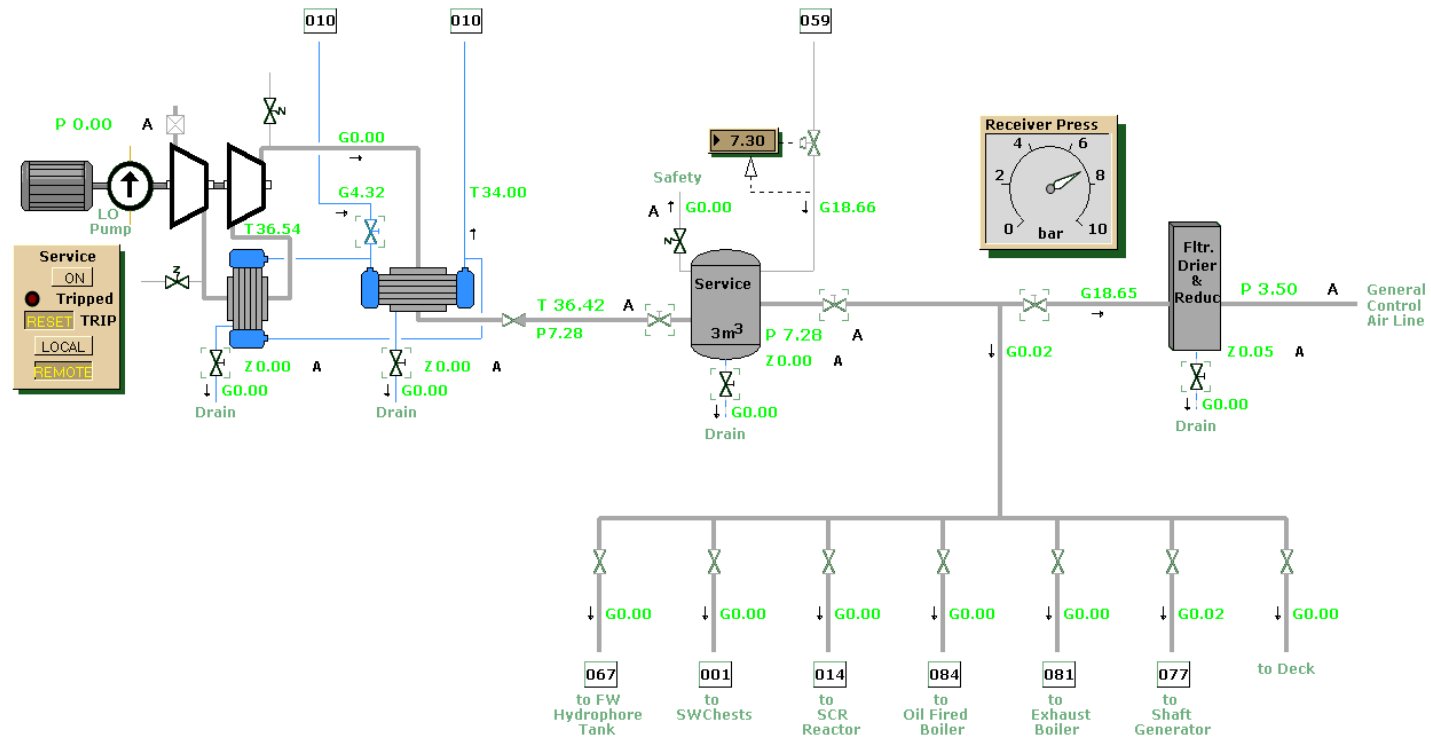

M

v

ERS - MC90-V 2.2.9999.0353 (03)

Unit Conversion	Message Log			Process Directory	Panel Directory	Process Overview	Back	Forward
-----------------	-------------	--	--	-------------------	-----------------	------------------	------	---------

## 5.5 Service Air Compressors MD60

### General

The purpose of the service air compressor system is to provide air to the control equipment and control valves in the engine room, and for general consumption purposes in engine room and at deck.

The compressed air system consists of one service air compressor, one service air receiver and a filter drier / reducer assembly for control air.

The compressor starts and stops automatically according to need by the compressor control system included in the PowerChief system if the compressor is in AUTO position.

### Description

The service air compressor is monitored by an independent, local safety system.

The air compressors will trip at:

	Service air comp.
Disch. air temp.	> 100°C
Lub oil press.	< 0.75 bar

The compressor is cooled by LT fresh water. High air outlet temperature is indicated by a red alarm light on the compressor panel.

The safety valve for the service air receiver opens at approximately 8.5 bar. The settings of the safety valve can be changed from the variable page.

The air receivers and the air coolers will gradually fill with water, depending on compressed air production and air humidity. The receivers and coolers must be manually drained regularly. Much water in the service air receiver will reduce the operating capacity.

The air to the control equipment is filtered and dried and pressure reduced by a pressure reduction valve (part of the filter/drier assembly).

If the service air compressor fails, make-up air can be taken from the #1 start air receiver. An air reduction control valve closes the make-up gradually at increasing service air pressure. The valve is pressure controlled, with an opening set point set slightly lower than the auto start set point of the service air compressor.

The air make-up valve is usually left open for safety reasons. If the service air compressor trips, service, and control air pressure is not lost, but supplied through the starting air receivers. This may prevent a serious situation like a shut down of the main engine in narrow waters.

Under certain conditions, starting air compressors "produce" a considerable amount of water. The starting air may also contain a small amount of oil. This will gradually reduce the efficiency of the



air dryer/cooler and is therefore not desirable. By keeping the service air compressor in service, carry over of dirty air from the starting air compressors to the control air system is prevented.

Carefully consider if or when to close the service air make-up valve.

### Operation procedure

#### 1. Preparations before starting start air compressors after a longer period out of operation.

- 1.1 Check that main sea water and LT fresh water systems are in operation and the valve to air compressor coolers is open.
- 1.2 Open fresh water inlet valve to service air cooler.
- 1.3 Open drain valve from service air cooler.
- 1.4 Open air inlet valve to service air receiver.
- 1.5 Operate drain valve from service air receiver to remove any water present.
- 1.6 Open air outlet valve from service air receiver.
- 1.7 Open air inlet valve to service air filter and dryer.
- 1.8 Operate drain valve from service air dryer to remove any water.

#### 2. Starting procedure

- 2.1 If the compressor is tripped (TRIPPED lamp lit), press RESET button on the compressor panel. Start the compressor by pressing button ON.
- 2.2 Close service air make-up valve from start air receiver no. 1 (see note).
- 2.3 Close drain valves.

- 2.4 Select AUTO mode on the PowerChief panel. The compressor will then start and stop according to the limits given. These limits are adjustable from the variable page 7020.  
**Note:** When a compressor is started manually, it is not stopped automatically by a pressure control.

### 3. Normal operation

- 3.1 The service air compressor is normally operated in AUTO mode
- 3.2 The stop valve for the make-up line is normally open.
- 3.3 Check that the set point of the make-up valve is slightly below the set point of the service air compressor.
- 3.4 Drain air receiver, air cooler, and filter drier regularly.

### Model particulars

The air flow delivered from the service air compressor is dependent on the discharge (receiver) pressure.

All main control valves included in the ship machinery are assumed to be air operated. As the control air pressure is reduced, these devices will be slower and the effective actuator time constants are increased. Various control loop problems may develop at low control pressure.

Some of the loops will be slow and stable, others conditionally unstable (unstable in an intermediate range).

The service air compressor in this system is often called an "instrument air compressor" and is usually of the "oil free" type. In



addition there is often a "working air compressor" supplying consumers not including delicate instrument systems.

Much water in the service air receiver will lead to problems with the oil viscosity controller. If the intermediate air cooler is not drained regularly, it will gradually fill with water and overheat.

00:00:26 Running	Picture MD 03	<b>Fuel Oil Transfer System</b>	Alarms	 
			Silence	

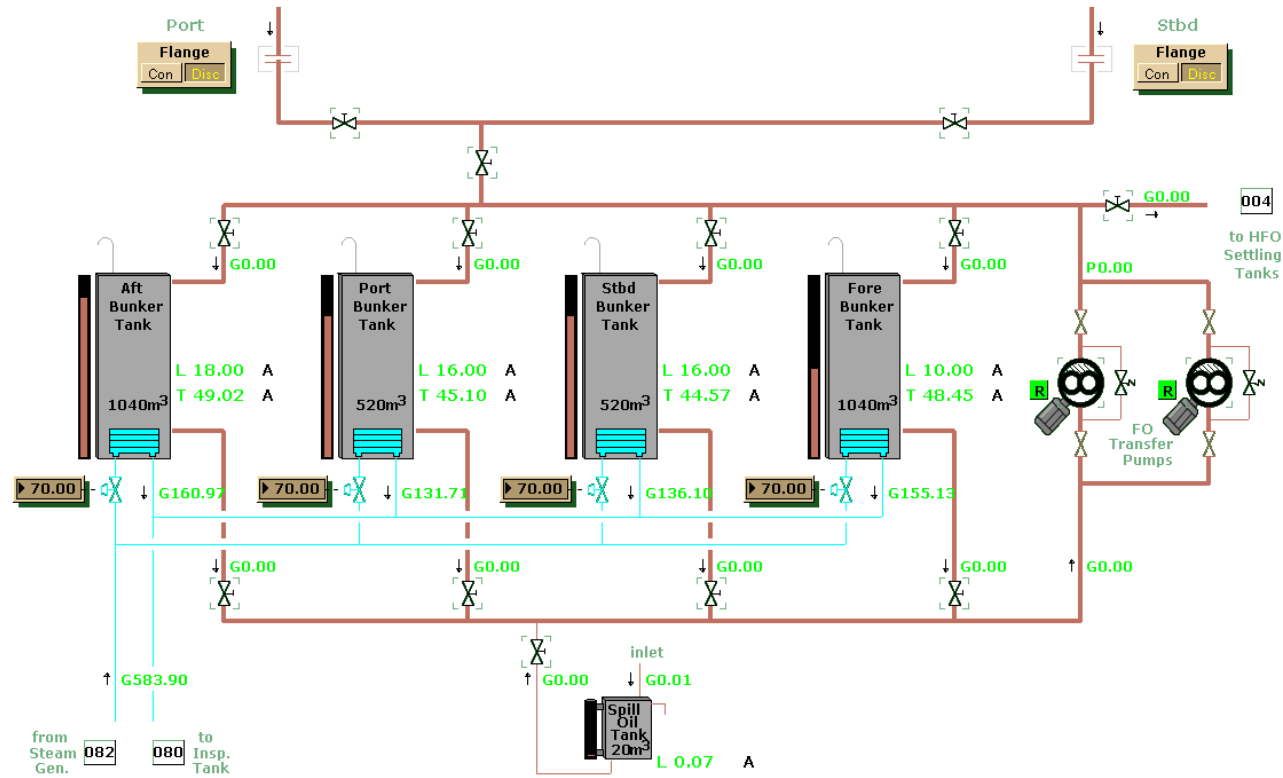

M

V

ERS - MC90-V 2.2.9999.0353 (02)

Unit Conversion	Message Log		Process Directory	Panel Directory	Process Overview	Back	Forward
-----------------	-------------	--	-------------------	-----------------	------------------	------	---------



## 5.6 Fuel Oil Transfer System MD03

### General

The heavy fuel oil transfer system includes four bunker tanks, one spill oil tank, a transfer pump and necessary piping. The transfer pump can take oil from any of the bunker tanks or the spill oil tank and discharge it to the settling tanks or back to the bunker tanks.

The bunker tanks are heated by steam. The heat transfer is proportional to the steam pressure which is set by manually controlled throttle valves. If the heating is turned off, the bunker tank temperature will slowly cool down towards ambient (SW) temperature.

The flow resistance in the heavy fuel oil lines is dependent on temperature. The resistance increases at temperatures below 60°C (140°F); below 20°C (68°F) no flow is possible.

The spill oil tank input comes from the following tanks:

#### *-over flow:*

- HFO settling tank 1
- HFO settling tank 2
- DO service tank

#### *-drain flow:*

- Venting Box

### Engine room fire

If high alarm in the spill oil tank is disregarded and the tank starts to overflow, engine room fire is likely to (will) develop. The fire can be extinguished after the following actions have been taken:

- The fuel oil tank quick closing valves shut
- The fuel oil pumps stopped
- The engine room ventilation fans stopped.
- The main engine stopped.
- The sea water fire line made operational.

### Operation procedure

- 1.1 Open inlet to selected tank from HFO transfer pump.
- 1.2 Open outlet from selected bunker tank.
- 1.3 Observe that transfer of oil between bunker tanks is possible.
- 1.4 Start transfer pump after opening of outlet valve. Normally one pump is sufficient.
- 1.5 Ensure that valves to bunker tanks are closed when transferring to settling tanks.

Fuel oil in the bunker tanks is to be heated and kept at a temperature corresponding to the temperature at delivery.

**Note:** If large amount of heavy fuel is transferred to the settling tank, it may cause a considerable temperature drop in the settling tank, which again may cause separator disturbance.

**Note:** Transfer of diesel oil is done with diesel oil purifier on separate instruction.



## 5.7 Fuel Oil Service Tanks MD05

### General

Fuel oil service tanks comprise the fuel oil service tank, the diesel oil storage tank, the diesel oil service tank and the separator systems for fuel oil and for diesel oil.

The fuel oil service tanks store and preheat the cleaned fuel oil.

The HFO service tank supplies fuel oil to:

- Fuel oil system.
- Boiler burner system.

The diesel oil service tank supplies diesel oil to:

- Fuel oil system.
- Generator engines
- Boiler burner system (when operated on diesel oil).

### Description

#### HFO service tank and HFO separator system

HFO separator 1 and 2 fill the HFO service tank.

Both HFO separators can take suction from:

- HFO Settling tanks.
- HFO service tank.

Both HFO separators discharge to:

- HFO service tank.
- HFO settling tanks

The fuel oil service tanks store and preheat the cleaned fuel oil.

Only one HFO separator would normally be in use

### Steam heating

The service tanks are equipped with steam heaters.

The temperature is controlled by simple P-controllers, positioning the steam control valves according to tank temperature and temperature set point.

The temperature in the service tanks will normally be maintained at a temperature corresponding to the normal discharge temperature from the separator.

All HFO supply and return lines are steam traced supplied from the steam reduction valve - refer to the FO service system.

### Miscellaneous

The HFO service tank has return pipes from venting tank, fuel oil system, and boiler burner system.

The diesel oil service tank has return pipe from the generator engines.

The HFO Service tank overflows to the HFO Settling tanks.

The DO Service tank overflows to the spill oil tank.

The service tanks are provided with drain valves and the drain are led to the Spill Oil tank.



The service tanks and the diesel oil storage tank are provided with shut off valves (quick-release, remote controlled shut-off valves) at the tank outlet.

### **Operation procedure**

- 1.1 Open the heating supply valve to the heating coils and set the desired temperature from the controller.
- 1.2 HFO service tank temperature controller to be set at 65°C
- 1.3 DO service tank to be set at 35°C
- 1.4 Settling tank temperature to be set 5-10°C below.
- 1.5 HFO requires temperatures above 20°C to be pumped.
- 1.6 Drain water from tanks periodically.

### **Model Particulars**

The heat effect is proportional to the steam flow, which depends on the control valve position and the steam pressure. The temperature of the service tanks depends on steam heating, loss to surroundings and temperature of inlet flow from purifier and return flows. The fuel oil viscosity in the service tanks is computed.

<This page is intentionally left blank>

00:00:29 Running	Picture MD 04	<b>Fuel Oil Settling Tanks</b>	Alarms		
			Silence		

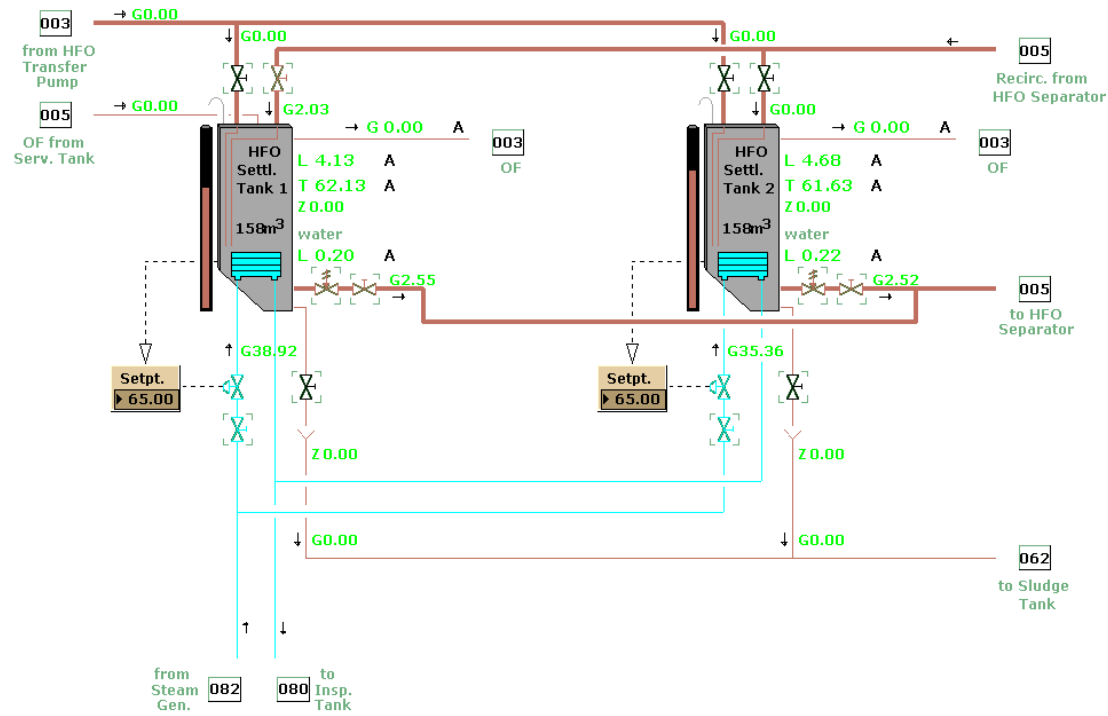

v

ERS - MC90-V 2.2.9999.0353 (01)

Unit Conversion	Message Log			Process Directory	Panel Directory	Process Overview	Back	Forward
-----------------	-------------	--	--	-------------------	-----------------	------------------	------	---------

## 5.8 Fuel Oil Settling Tanks MD04

### General

Fuel oil settling tanks comprises HFO Settling tank no. 1 and no. 2.

The purpose of the HFO settling tanks is to:

- Settle bulk water and sludges
- Act as buffer tank for the HFO separator system
- Supply the HFO separators with fuel oil of an almost constant temperature

### Description

There are two identical HFO settling tanks. Both tanks are filled from the oil transfer system by the HFO transfer pumps taking suction from either the bunker tanks or the fuel oil spill tank. The filling line at each settling tank is provided with a shut-off valve.

By means of shut-of valves (quick-release, remote controlled shut-off valves) at the outlet from each HFO Settling tank and associated piping system, provision is made to have the HFO separators to take suction from one or both settling tanks.

Bulk water settled in the settling tanks can be drained from the bottom of the tank to the sludge tank via a drain valve.

### Steam heating

The temperature is controlled by simple thermostatic P-controllers, positioning the steam control valves according to tank temperature and temperature set.

### Miscellaneous

Overflow from the settling tanks is led to the Spill Oil tank. Each HFO settling tank has a return line with shut-of valve for excess oil from the HFO separator feed pumps.

### Operation procedure

- 1.1 Open the heating supply valve to the heating coils and set the desired temperature from the controller.
- 1.2 Settling tank temperature to be set 5-10°C below flash point.
- 1.3 HFO requires temperatures above 40°C to be pumped.
- 1.4 Drain water from tanks periodically.
- 1.5 Water content can be read in %.

### Model particular

- If the temperature of the oil in the settling tank cools below a certain limit (40°C), it will be difficult for the purifier feed pump to transport the oil.
- The process of water precipitation in the settling tanks is properly modelled so that the water in the oil from the bunker tank will gradually fall towards the tank bottom by force of gravity. The water content in the oil from the bunker tank can be adjusted.
- If the collected water is not discharged regularly, HFO purifier problems will finally be experienced (such as excess water to sludge tank).
- In order to simulate visual inspection of the water/oil mixture, oil/water interface level is presented on screen at each tank.



---

*If local engine room panels are used in the simulator configuration:*

*The drain valves can be opened at the local panel. In order to simulate visual inspection of the water/oil mixture, use is made of the panel light of the valve. A steady light indicates that the valve is open and water is flowing. A flashing light indicates that the valve is open and mostly oil is flowing. Note that the flashing light function is available only when Local Panel is used for operating the fuel oil settling tanks, in the engine room.*



<This page is intentionally left blank>

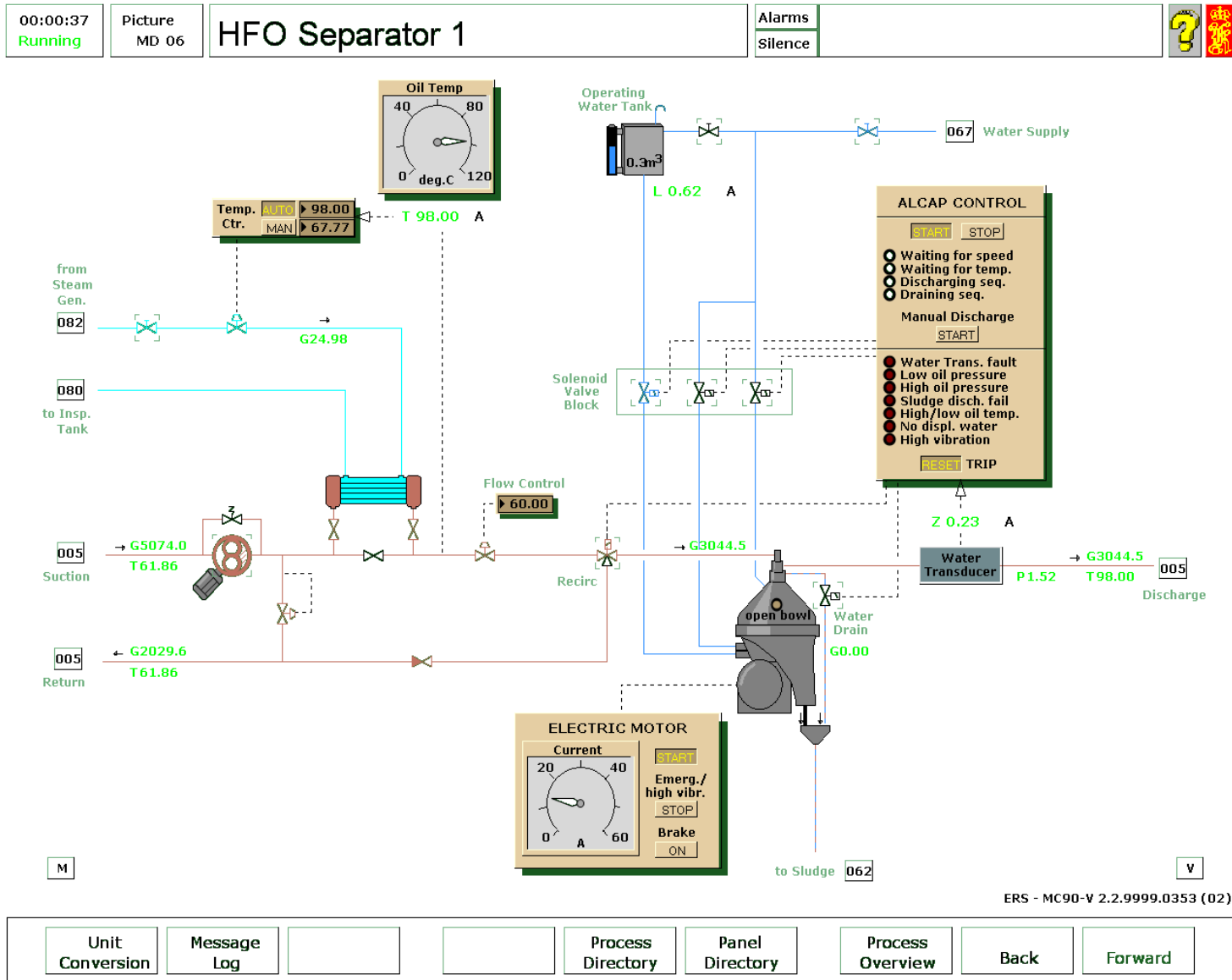

## 5.9 HFO Separator System MD06

### General

The purpose of the HFO separator system is to supply the main engine and the diesel generators with fuel oil, free from impurities and water to the highest degree.

### Description

There are two HFO separators of the "ALCAP" type. The two HFO separators take suction from the settling tanks and the service tank and discharge to the HFO service tank.

### Operation Mode

#### Pumping up service tank:

One separator takes suction from the selected HFO settling tank and discharge to the HFO service tank.

#### Re-circulating service tank:

One separator takes suction from the HFO service tank and discharge to the HFO service tank.

Each separator is provided with a separate electrical driven feed pump with constant displacement. The flow to the separator is controlled by means of an adjustable flow control valve. The excess flow from the feed pump is returned to the HFO settling tank or to the HFO service tank.

Each feed pump/separator has a capacity, which is 10% above maximum total HFO consumption

Each separator is provided with an operation water gravity tank. During operation, there is a constant consumption of operating water and the operating water gravity tank must be manually refilled on low alarm.

The oily water sludge and the drain from the shooting are collected in the sludge tank.

A steam heated pre-heater heats the heavy fuel oil before it is led to the separator bowl. A PID controller controlling a control valve at the pre-heater steam inlet controls the temperature.

### ALCAP Operating Principle

The oil to be cleaned is continuously fed to the separator. Separated sludge and water accumulate at the periphery of the bowl.

Normally a sludge discharge takes place at specific time intervals, but if the water contamination is high, an earlier discharge may be initiated.

When separated water reaches the disk stack, some water escapes with the cleaned oil. The increase in water content is sensed by a water transducer installed in the clean oil outlet.

When the water content in the cleaned oil reaches a specific "trigger level", the control program will initiate an automatic discharge of the water in the bowl. The water is discharged with the sludge through the sludge ports at the periphery of the bowl.

If the water contamination is so high that the "trigger" level is reached within 15 minutes (adjustable) after the last sludge discharge, the water drain opens. The valves remain open for a



specific time after the water content has passed the “trigger” level on its way down.

If the water content in the cleaned oil does not decrease below the “trigger” level within 2 minutes after a sludge discharge or a water discharge through the water drain valve, there will be an alarm and the inlet oil valve will close.

On the ALCAP control panel there are indications of the following alarms:

- Water Transducer Failure
- Sludge Discharge Failure
- High Oil Pressure
- Low Oil Pressure
- High/Low Oil Temperature
- No Displ. Water
- High Vibration

Water transducer failure alarm is activated if the transducer is measuring less than 0.05% water content in the outlet oil. Since it is not possible to measure a water content below this value in this separator system, this limit is used to indicate a fault condition of the transducer.

After repair of transducer, the ALCAP must be reset before it is possible to start the separator.

High oil outlet pressure alarm is indicated when oil pressure out is more than 1.9 bar.

Low oil outlet pressure alarm is indicated when oil pressure out is less than 1.45 bar.

High/Low oil temperature alarm is activated if the oil temperature differs more than 5% from setpoint. This malfunction can be triggered from the malfunction page M0604 (Heater failure) or by changing setpoints directly on the heater controller when the controller is set to manual operation.

When the oil temp is within 5% from setpoint reset the ALCAP before start.

No displ. water alarm is activated when the ALCAP control system tries to fill water but there is no water supply caused of a shut water supply valve.

When the water supply is reinstated reset the ALCAP before start.

High vibration alarm is activated when we have high vibration in the separator bowl. When this alarm is activated, the separator will be emptied, the ALCAP control system will be shut down, the oil will be recirculated (three way valve will close against separator) and the electrical motor will stop. This malfunction is set from the malfunction page M0602.

After repair reset the ALCAP before start.

Sludge discharge failure alarm is activated if the separator is not able to empty the separator for water and sludge. The ALCAP control system will directly try a new sludge/discharge sequence. If the water transducer still measures too high water content in the oil,



the separator will be emptied, the ALCAP control system shut down and the oil will be recirculated.

After repair reset the ALCAP before start.

### Operation procedure

- Normally only one HFO purifier is in service. The HFO purifier in service takes suction from one of the settling tanks and discharge to the service tank.
- The flow through the HFO purifier in service should always be adjusted according to the current HFO consumption in order to optimise the purification at all times.

#### 1. Preparation

- 1.1 Open outlet valve from selected HFO settling tank.
- 1.2 Open HFO SEP oil inlet valve to separator.
- 1.3 Open HFO SEP oil outlet valve to HFO service tank.
- 1.4 Open HFO SEP HEATER STEAM shut off valve.
- 1.5 Open valve for displacement water.
- 1.6 Drain settling tank.

#### 2. Starting procedure:

- 2.1 Start HFO SEP feed pump. Adjust desired flow to approx 50.
- 2.2 Set temperature controller to AUTO and adjust set point to 98°C.
- 2.3 Check that the purifier brake is not engaged.
- 2.4 Start electric motor of the purifier.
- 2.5 Wait for purifier speed to stabilise. Observe the ammeter and “waiting for speed” indication on ALCAP control panel.
- 2.6 Put the ALCAP control into operation by pressing the start button on the control panel.

When correct oil temperature (observe indication on the ALCAP control panel), the three way valve will open for delivery to the separator.

- 2.7 Observe and adjust flow rate to be slightly greater than nconsumption.

#### 3. Stopping procedure

- 3.1 Perform a manual discharge
- 3.2 When discharge sequence has finished, push the stop button on the ALCAP control panel.
- 3.3 Stop the purifier
- 3.4 Stop the feed pump
- 3.5 If high vibration occurs stop the purifier and engage the brake immediately.

#### Model particulars

- The purifier is modelled with an automatic dirt build up within the bowl. After each shooting sequence, the bowl is cleaned. If the dirt cumulative exceeds an upper limit, the cleaning efficiency will be reduced. The purifier therefore must be shot regularly.

The amount of water separated is dependent of the water content in the settling tank

00:00:44 Running	Picture MD 08	<b>DO Purifier System</b>	Alarms	
			Silence	

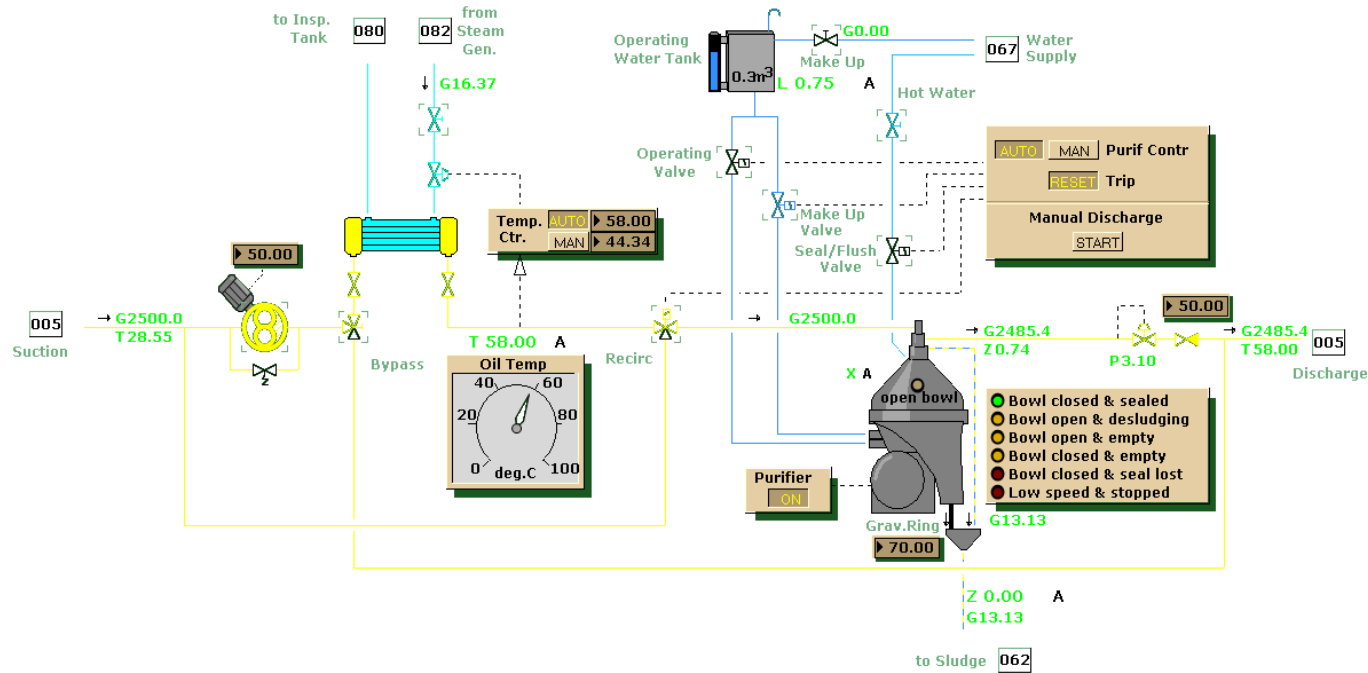

M

V

ERS - MC90-V 2.2.9999.0353 (03)

Unit Conversion	Message Log			Process Directory	Panel Directory	Process Overview	Back	Forward
-----------------	-------------	--	--	-------------------	-----------------	------------------	------	---------

## 5.10 Diesel Oil Separator System MD08

### General

The purpose of the diesel oil separator system is to supply the main engine and the generator engines with diesel oil, free from impurities and water.

### Description

There is one diesel oil separator. The diesel oil separator takes suction from the diesel oil storage tank and discharge to the diesel oil service tank.

The separator is provided with a separate electrical driven displacement feed pump with adjustable speed.

By means of a 3-way changeover valve located before the pre-heater, the feed pump may discharge directly to the service tank, bypassing the separator.

The separator is provided with an operation water gravity tank. During operation, there is a constant consumption of operating water and the operating water gravity tank must be manually refilled on low alarm.

The sealing water is supplied from the hot water system

The oily water sludge and the drain from the shooting are collected in the sludge tank.

A steam-heated pre-heater may heat the diesel oil before it is led to the separator bowl. The temperature is controlled by a PID controller controlling a control valve at the pre-heater steam inlet.

### Operation procedure

#### Normal operation:

- a) The separator feed pump takes suction from the diesel oil storage tank and discharge to the diesel oil service tank via the diesel oil separator.
- b) The separator feed pump takes suction from the diesel oil service tank and discharge to the diesel oil service tank via the diesel oil separator.

#### Emergency operation:

The separator feed pump takes suction from the diesel oil storage tank and discharge directly to the diesel oil service tank.

#### 1. Preparation

- 1.1 Open outlet valve from diesel oil storage tank. Open inlet valve to diesel oil service tanks.
- 1.2 Start purifiers feed pump. Adjust desired flow by using the variable delivery supply pump (when starting less than 20%).
- 1.3 Set temperature controller in auto and adjust set point to 60°C. Start purifier by pushing the ON button.
- 1.4 Fill operating water tank if necessary.
- 1.5 Open make up water valve (Hot water for bowl content displacement).



## **Starting procedure**

### **2. MANUAL mode:**

After purifier has reached full speed, and purifier controller is in manual, open make-up valve and wait until mimic reads BOWL CLOSED AND EMPTY

- 2.1 Open seal/flush valve for 15 seconds to ensure proper water seal in bowl.
- 2.2 When mimic reads BOWL CLOSED AND SEALED, open oil flow to purifier by clicking open on three way re-circulation valve towards purifier. The supplied oil must have sufficient temperature.
- 2.3 Start purifying process with gravity ring less than 50% of full scale.
- 2.4 Adjust gravity ring to maximum value without losing water seal and adjust oil flow gradually to 100 %.

### **3. Ejection cycle:**

- 3.1 Change over re-circulation valve.
- 3.2 Open seal/flush valve for 5 seconds to empty bowl.
- 3.3 Close make-up valve.
- 3.4 Open operating valve for 5 seconds, mimic reads BOWL OPEN DESLUDGING
- 3.5 Open operating valve for 5 seconds, mimic reads BOWL OPEN, EMPTY.
- 3.6 Open operating valve for 5 seconds, mimic reads BOWL CLOSED & EMPTY .
- 3.7 Open make-up valve,
- 3.8 Open Seal/Flush valve.until mimic reads BOWL CLOSED AND SEALED

- 3.9 When operating valves, indicating lamps must be observed to prevent rushing the procedure of starting cycle/ejection cycle.
- 3.10 Adjust the back pressure valve to maintain about 3 barg.

### **4. AUTO mode**

- 1.1 Press purifier on button
- 1.2 When purifier is up to speed, press start and switch to auto.
- 1.3 Adjust back pressure valve to maintain about 3 barg.

### **5. Re-purification of diesel oil service tank:**

- 5.1 Open fuel oil purifier suction valve from diesel oil service tank.
- 5.2 Close fuel oil purifier suction valve from diesel oil settling tanks.
- 5.3 Open fuel oil discharge valve from purifier to diesel oil service tank.
- 5.4 Close fuel oil discharge valve to diesel oil storage tank.
- 5.5 Always open valves on diesel oil service tank before closing valve on diesel oil storage tank.

### **6. Adjusting gravity ring:**

- 6.1 The efficiency of the purifier is dependent on the gravity ring setting and the feed flow. Low feed flow and large gravity ring result in better purification while small gravity ring increases the maximum flow admitted before broken water seal is likely to occur.
- 6.2 The cleaning must always be optimised according to the required flow through purifier.
- 6.3 The gravity ring is slowly maximised until oil is observed in the sludge flow.





6.4 When oil is observed the sludge flow, decrease the gravity diameter a few percent until there is no oil in the sludge flow.

**Model particulars**

The oil discharge pressure will build up to normal value when the separation process starts functioning properly.

The oily water sludge and the drain from the shooting is collected in a sludge tank common for all purifiers. At loss of water seal, the oil/water will drain through sludge line to sludge tank. The oil discharge pressure will be low and the central alarm system will be activated.

The purifier is modulated with an automatic dirt build up within the bowl. After each ejection cycle, the bowl is cleaned. If the dirt accumulated exceeds an upper limit, lost water seal will occur. The purifier therefore must be cleaned regularly.

If the oil inlet temperature drops under a given limit or increases above a given limit, the normal separation process is disturbed, resulting in lost water seal. If the flow resistance of the discharge line is too high, the water seal will break.

If the oil temperature reaches a critical low limit, the purifier will stop due to motor overload.

There is a constant consumption of operating water and the operating water tank must be manually refilled on low alarm or before.

The efficiency of the purifier is dependent on the gravity ring setting and the feed flow. Low feed flow and large gravity ring result in better purification while small gravity ring increases the maximum flow admitted before broken water seal is likely to occur.

The cleaning procedure described will be done automatically at regular intervals by the PowerChief central monitoring system if the selector switch on the local purifier panel is in AUTO position

00:00:47 Running	Picture MD 09	<b>LO Purifier System</b>	Alarms	
			Silence	

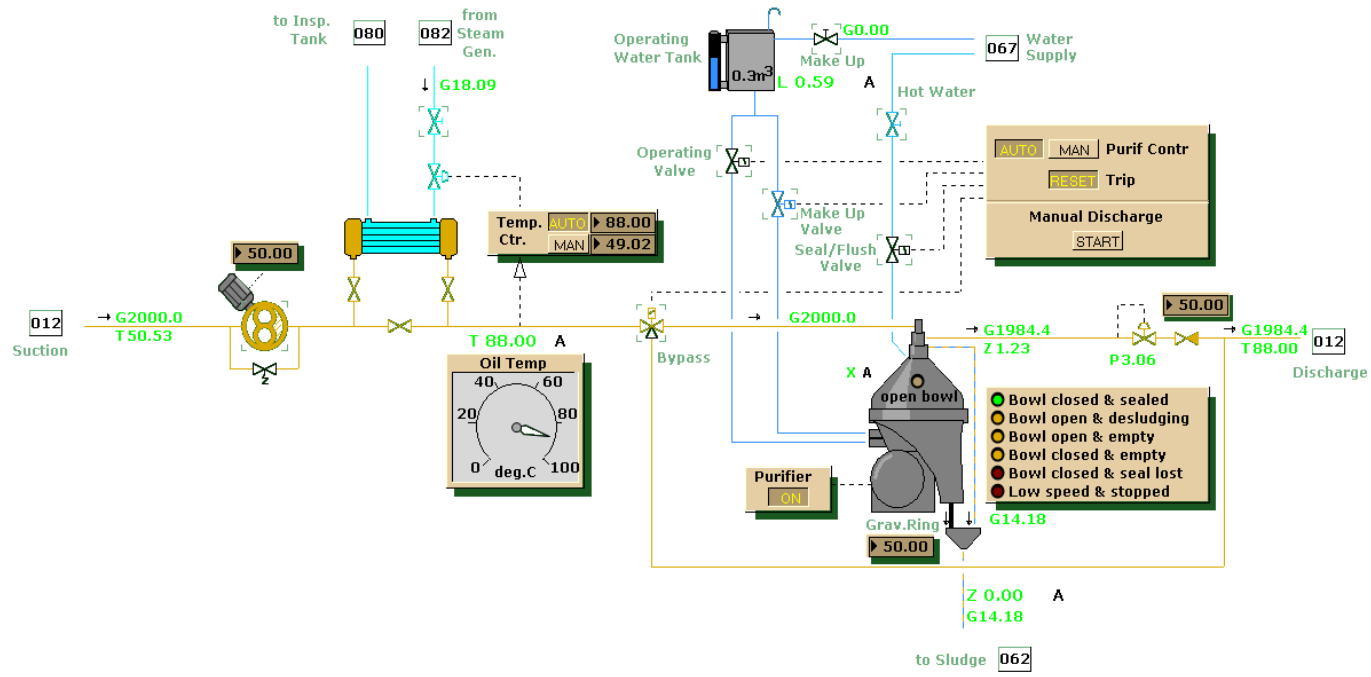

M v

ERS - MC90-V 2.2.9999.0353 (02)

Unit Conversion	Message Log			Process Directory	Panel Directory	Process Overview	Back	Forward
-----------------	-------------	--	--	-------------------	-----------------	------------------	------	---------

## 5.11 Lubrication Oil Purifier System MD09

### General

#### Description

There is one lubricating oil separator. The lubricating oil separator takes suction from one end of the main engine drain tank and discharges back to the other end of the drain tank.

The separator is provided with a separate electrical driven displacement feed pump with adjustable speed.

The separator is provided with an operation water gravity tank. During operation there is a constant consumption of operating water and the operating water gravity tank must be manually refilled on low alarm.

Sealing water is taken from the hot water system.

The oily water sludge and the drain from the shooting are collected in the sludge tank.

A steam-heated pre-heater may heat the oil before it is led to the separator bowl. The temperature is controlled by a PID controller controlling a control valve at the pre-heater steam inlet.

#### Operation procedure

##### 1. Preparation

- 1.1 Open outlet valve from lubrication oil sump tank.
- 1.2 Open inlet valve to lubrication oil sump tank
- 1.3 Start feed pump. Adjust desired flow (when starting less than 20%).
- 1.4 Set temperature controller in auto and adjust set point to 88°C.

- 1.5 Start purifier by pushing the ON button.
- 1.6 Fill operating water tank if necessary.
- 1.7 Open make up water valve (Hot water for bowl content displacement)

#### Starting procedure

##### 2. MANUAL mode:

After purifier has reached full speed, and purifier controller is in manual, open make-up valve and wait until mimic reads BOWL CLOSED AND EMPTY

- 2.1 Open seal/flush valve for 15 seconds to ensure proper water seal in bowl.
- 2.2 When mimic reads BOWL CLOSED AND SEALED, open oil flow to purifier on three way inlet valve. The supplied oil must have sufficient temperature.
- 2.3 Start purifying process with gravity ring less than 50 % of full scale.
- 2.4 Maintain the back pressure at 3 barg.
- 2.5 Adjust gravity ring to maximum value without losing water seal and adjust oil flow gradually to 100 %.

##### 3. Ejection cycle:

- 3.1 By-pass the purifier with the inlet valve
- 3.2 Close make-up valve.
- 3.3 Open Seal/Flush valve for 5 seconds
- 3.4 Open operating valve for 5 seconds, mimic reads BOWL OPEN DESLUDGING



- 3.5 When mimic reads BOWL OPEN & EMPTY, open operating valve,
- 3.6 When mimic reads BOWL CLOSED & EMPTY open make up valve.
- 3.7 Open seal/flush valve until mimic reads BOWL CLOSED AND SEALED
- 3.8 When BOWL CLOSED AND SEALED appears, open inlet valve towards purifier.
- 3.9 When operating valves, indicating lamps must be observed to prevent rushing the procedure of starting cycle/ejection cycle.
- 3.10 Adjust back pressure valve to maintain about 3 barg.

#### 4. AUTO mode

- 4.1 Press purifier on button wait for purifier to run up to speed.
- 4.2 Press start and switch to auto.
- 4.3 Adjust backpressure valve to maintain about 3 barg.

#### 5. Adjusting gravity ring

- 5.1 The efficiency of the purifier is dependent on the gravity ring setting and the feed flow. Low feed flow and large gravity ring result in better purification while small gravity ring increases the maximum flow admitted before broken water seal is likely to occur.
- 5.2 The cleaning must always be optimised according to the current flow through purifier.

**The gravity ring is slowly maximised until oil is observed in the sludge flow.**

- 5.3 When oil is observed the sludge flow, decrease the gravity diameter a few percent until there is no oil in the sludge flow.

#### Model particulars

The oil discharge pressure will build up to normal value when the separation process starts functioning properly.

The oily water sludge and the drain from the shooting is collected in a sludge tank common for all purifiers. At loss of water seal, the oil/water will drain through sludge line to sludge tank. The oil discharge pressure will be low and the central alarm system will be activated.

The purifier is modulated with an automatic dirt build up within the bowl. After each ejection cycle, the bowl is cleaned. If the dirt accumulated exceeds an upper limit, lost water seal will occur. The purifier therefore must be cleaned regularly.

If the oil inlet temperature drops under a given limit or increases above a given limit, the normal separation process is disturbed, resulting in lost water seal. If the flow resistance of the discharge line is too high, the water seal will break.

If the oil temperature reaches a critical low limit, the purifier will stop due to motor overload.

There is a constant consumption of operating water and the operating water tank must be manually refilled on low alarm or before.

The efficiency of the purifier is dependent on the gravity ring setting and the feed flow. Low feed flow and large gravity ring result in better purification while small gravity ring increases the



maximum flow admitted before broken water seal is likely to occur.

The cleaning procedure described will be done automatically at regular intervals by the PowerChief central monitoring system if the selector switch on the local purifier panel is in AUTO position

00:02:13 Running	Picture MD 61	<b>Fresh Water Generator</b>	Alarms	 
			Silence	

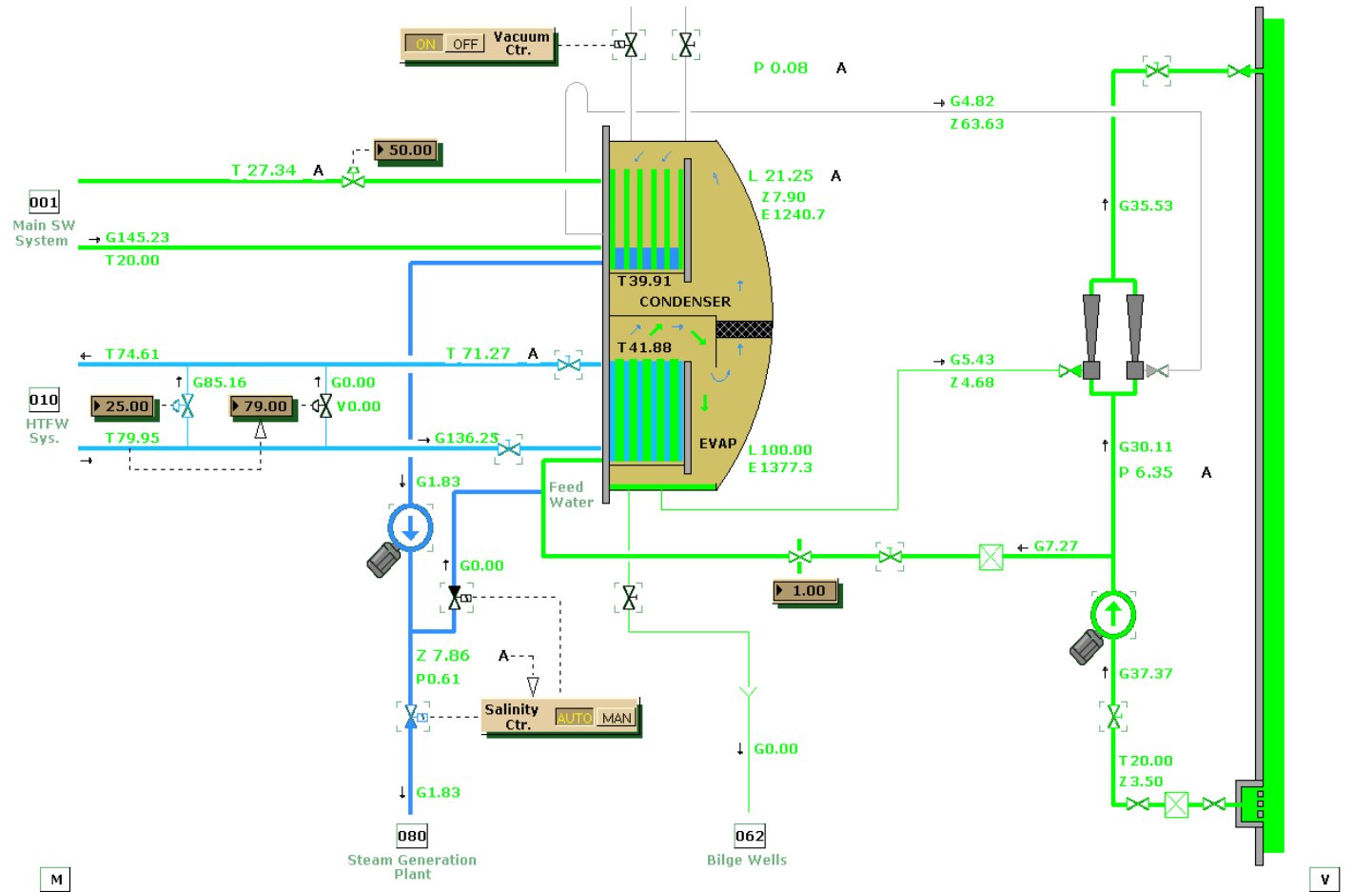

ERS - MC90-V 2.2.9999.0353 (01)

Unit Conversion	Message Log		Process Directory	Panel Directory	Process Overview	Back	Forward
-----------------	-------------	--	-------------------	-----------------	------------------	------	---------

## 5.12 Fresh Water Generator MD61

### General

Very huge waste heat sources may be utilised when connecting a fresh water generator to the main engine jacket cooling water system. Normally this temperature is 75-80°C.

There are two HTFW bypass valves. The manually operated valve diverts the HTFW through the evaporator to evaporate the sea water feed.

An automatic bypass valve is also mounted in the HTFW supply line to the evaporator. It is normally closed, but at engine outlet temperatures lower than normal, it opens. This function prevents the evaporator from over-cooling the engine at low engine power, when the heat generation in the engine is insufficient for full evaporator production.

A controlled amount of sea water is fed into the evaporator where it is heated by the HTFW. The fresh water generator operates under vacuum conditions in order to reduce the evaporation temperature. The vacuum, and thus the evaporation temperature, must be controlled to reduce the scale formation in the sea water side of the evaporator.

The vacuum allows the utilisation of low temperature heating sources. The vapours generated pass through a fine mesh, to prevent salt water carryover, to the condenser.

The condenser is cooled by sea water so the vapour condenses into fresh water. The fresh water falls by gravity to the bottom of the condenser and is led to the suction of the fresh water pump.

The condition of the fresh water is monitored by a salinometer and if the salinity is high the condensate is recirculated to the evaporator.

### Description

The evaporator is made up by heat exchangers of the plate type.

The evaporator heating is supplied from the main engine HTFW circuit by controlling a bypass valve.

The maximum evaporator capacity is 30 ton/24 hours at sea water temperature 32°C.

The distillate water is led to the distilled fresh water tank

### Operation procedure

#### 1. Preparation

- 1.1 Set salinity controller to MAN.
- 1.2 Close evaporator drain valve.
- 1.3 Close vacuum breaker valve.
- 1.4 Check that fresh water by-pass valve is fully open.
- 1.5 Check that fresh water inlet and outlet valves from main engine system to generator are closed.
- 1.6 Close sea water feed valve from ejector pump
- 1.7 Open valve for sea water supply to ejector pump



- 1.8 Open sea water valve for condenser (V00674, MD01)
- 1.9 Open sea water overboard valve from ejectors.

**2. Starting procedure:**

- 2.1 Start ejector pump and check pressure and flow.
- 2.2 Open sea water flow to condenser, adjusting valve, gradually to 100 %.
- 2.3 Open sea water feed valve to evaporator.
- 2.4 Wait for the total pressure in the generator to drop to approximately 0.10 bara.
- 2.5 Open evaporator heating outlet shut off valve (to HTFW system).
- 2.6 Open evaporator heating inlet shut off valve (from HTFW system).
- 2.7 Close evaporator heating by-pass valve gradually while checking that the generator pressure does not exceed 0.1 bara.
- 2.8 Activate the automatic vacuum control valve by pressing ON at Vacuum Ctr. panel.
- 2.9 When distilled fresh water is visible in sight glass, open distillate re-circulation valve and start the distillate pump.
- 2.10 When salinity control is below alarm limit, activate salinity control by pressing AUTO at Salinity Ctr. panel

**Model particulars**

No comments.



<This page is intentionally left blank>

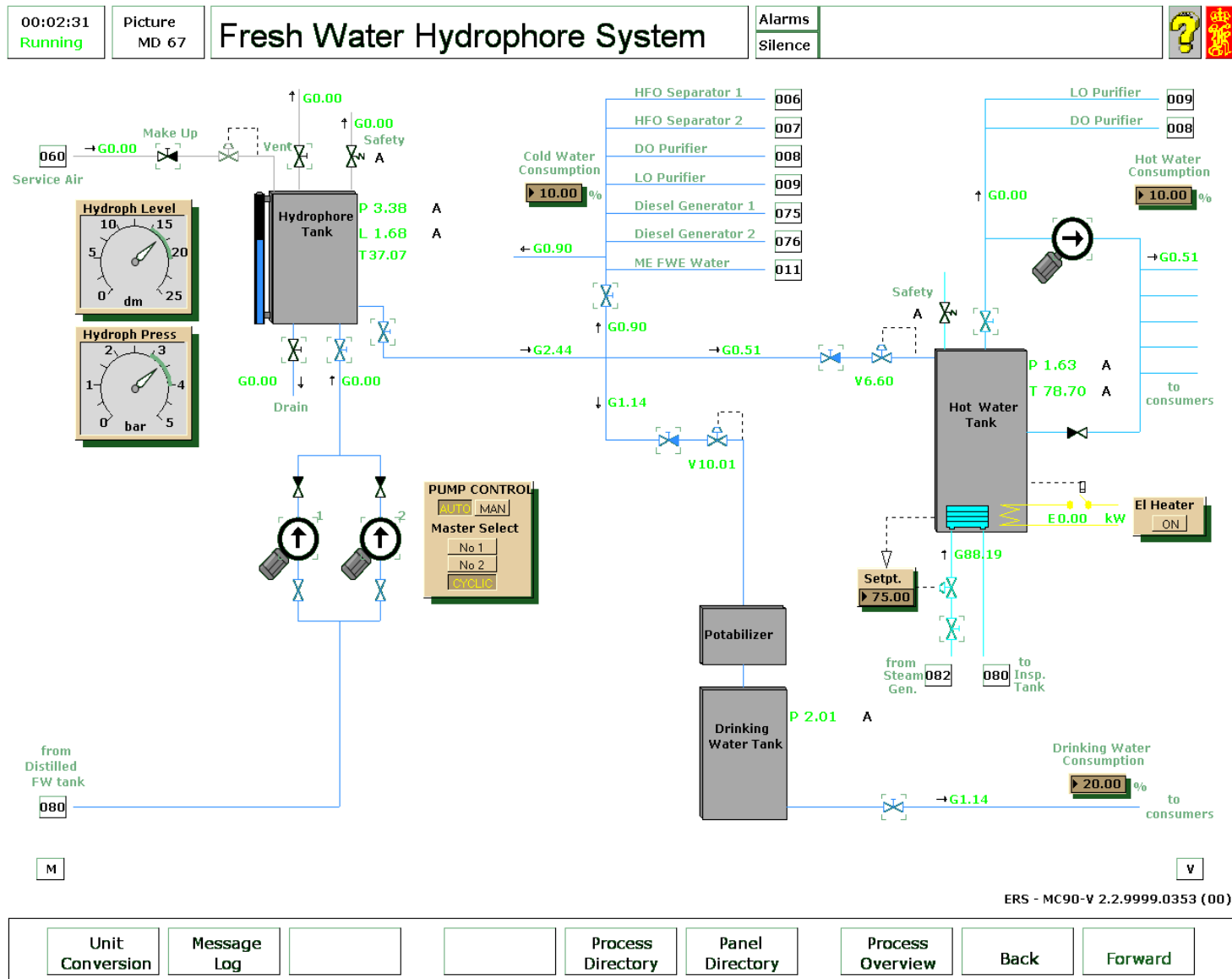

## 5.13 Fresh Water Hydrophore System MD67

### General

Fresh Water Hydrophore System, MD67, consists of a pressurised hydrophore tank with necessary pumps and valves, a drinking water tank and a hot water tank.

The hot water is heated by electric immersion heater or steam.

The drinking water is supplied via a potabiliser to sterilise before use.

The capacity of the system is approx. 10 t/h of cold water, hot water and drinking water, supplied to different users.

The hydrophore tank volume is 3.0 m<sup>3</sup>, pressure is kept between 3 and 4 bar.

The system interfaces to the following subsystems:

- Cold Water
  - Purifiers
  - Generator FW make up
  - ME FW make up
  - Other consumers – consumption adjustable
- Hot water
  - LO and DO purifiers sealing water
  - Other consumers – consumption variable
- Drinking water
  - Other consumers – consumption variable.

### Operation procedure

#### 1. Preparation

- 1.1 Main busbar to be active.

### Starting procedure

#### 2. MANUAL mode:

- 2.1 Open valve from distilled FW tank .
- 2.2 Set pump control to MAN.
- 2.3 Start pump.
- 2.4 Open for service air if necessary.
- 2.5 Set temperature controller (steam or electric) to suitable value.
- 2.6 Start hot water circulation pump.
- 2.7 Open valves to consumers.

#### 5. AUTO mode

- 5.1 Open valves and set temp.controllers as in manual.
- 5.2 Set pump control to AUTO.
- 5.3 Select which pump to be the master pump.

#### 6. Cyclic

- 6.1 Set pump control to AUTO.
- 6.2 Press the button CYCLIC.

## 5.14 Bilge System and Bilge Separator MD62 & MD63

### Pollution prevention

To reduce pollution of the world's coasts and waters by the shipping industry, a great number of laws, regulations and penalties have been established and are being enforced. These include regulations set forth by the International Convention for the Prevention of Pollution from Ships, 1973, as modified by the Protocol of 1978 (MARPOL 73/78 Annex I), the Federal Water Pollution Control Act of 1970 (FWPCA), and the Oil Pollution Act of 1990 (OPA 90).

Of greatest interest aboard the training ship are the regulations concerning the pumping of machinery space bilge. The law, as established by MARPOL 73/78 ANNEX I, for ships of four hundred gross tons and above, defines permissible discharge of oil or oily waste from machinery space bilge as follows:

1. **All vessels outside special areas, machinery space discharge allowed when:**
  - 1.1. the ship is en-route
  - 1.2. the oil content, without dilution, does not exceed 15 PPM
  - 1.3. the oily mixture passes through approved oil filtering equipment
  - 1.4. In vessels over 10,000 grt the discharge is automatically stopped when the oil content exceeds 15ppm.
  - 1.5. the bilge water does not originate from cargo pump room bilges
  - 1.6. the bilge water is not mixed with oil cargo residues
2. **When the vessel is anywhere within a "Special Area"** which includes the entire Mediterranean Sea, Black Sea, Baltic Sea,

Red Sea, Gulf Areas, North West European waters and Antarctic; *No Discharge* is permitted, except when:

- 2.1. The vessel is underway, and
- 2.2. the ship is en-route
- 2.3. the oil content, without dilution, does not exceed 15 PPM
- 2.4. the oily mixture passes through approved oil filtering equipment
- 2.5. In vessels over 400 grt the discharge is automatically stopped when the oil content exceeds 15ppm.
- 2.6. the bilge water does not originate from cargo pump room bilges
- 2.7. the bilge water is not mixed with oil cargo residues

The MARPOL regulations are more restrictive for oil tankers, and slightly more flexible for vessels of less than 400 gross tons. Before pumping bilge on your license, make sure you understand the law.

**It is no longer legal anywhere in the world to pump machinery space bilge directly overboard without going through some kind of oil content monitor that will automatically stop the discharge when the legal limits are exceeded!**

In addition, U.S. laws prohibit any discharge which forms a sheen, sludge, film, or emulsion in U.S. territorial seas. Such seas are defined by the navigable waters, including river systems and tributaries or into or upon waters of the contiguous zone. The Department of Justice may prosecute an unlawful discharge or act in Federal District Court. Penalties set down by OPA 90 and the



FWPCA are generally up to \$25,000 per day of violation or \$1,000 per barrel discharged. The master of the ship must immediately notify the nearest Coast Guard of an unlawful discharge and proceed in the clean up. Gross negligence or wilful misconduct could cause penalty costs to triple.

MARPOL regulations also require every vessel to maintain an *Oil Record Book*, where a permanent record of almost every handling of oil or oil waste is maintained. For non tank vessels, the following operations must be recorded in the oil record book:

- Collection and disposal of oil residues (sludge)
- Automatic and Non-automatic discharge overboard or disposal otherwise of bilge water which has accumulated in machinery spaces.
- Condition of oil discharge monitoring and control system (failures and repairs)
- Accidental or other exceptional discharge of oil
- Bunkering of fuel or bulk lubricating oil
- Additional operational procedures and general remarks

The FWPCA and OPA 90 established additional regulations regarding the transfer of oil to or from a vessel. They state that no person may perform oil transfer operations unless he holds a valid license authorising service on such vessels as a master, mate, or engineer, and has full knowledge of current oil transfer procedures that are maintained aboard that vessel.

During vessel-to-vessel transfers each tank vessel with a capacity of 250 or more barrels of cargo oil must have a means that enables continuous two way communication between the person in charge of the transfer of operations on both vessels.

There must be onboard an emergency means to enable a person in charge of an oil transfer operation to stop the flow of oil to a facility, another vessel or within the vessel. This may be by the means of the pump control, quick acting power actuated valve or an operating procedure. There must be adequate and protected lighting in areas of oil transfer operation.

It is your responsibility as a marine engineer to know, understand, and obey the law.

00:02:20 Running	Picture MD 62	<b>Bilge Wells/Sludge Tank</b>	Alarms	
			Silence	

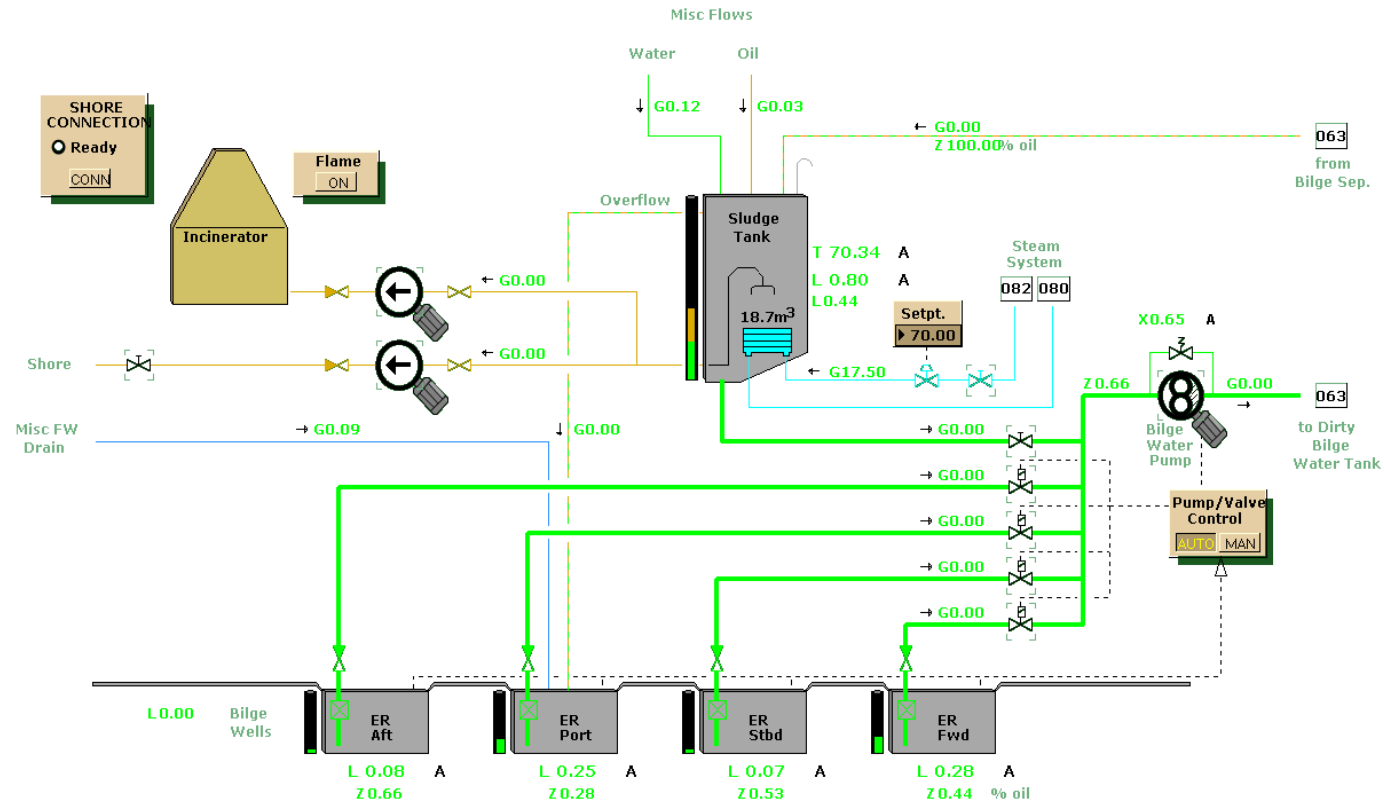

M

V

ERS - MC90-V 2.2.9999.0353 (01)

Unit Conversion	Message Log		Process Directory	Panel Directory	Process Overview	Back	Forward
-----------------	-------------	--	-------------------	-----------------	------------------	------	---------

### 5.14.1 Bilge Wells MD62

#### General

Bilge well description

The following Engine Room bilge wells are included:

- ER Aft
- ER Port
- ER Stbd
- ER Fwd

A sludge tank and an incinerator are also part of the bilge system.

The bilge pump can take suction from any of the four bilge wells, or from the sludge tank, and discharge it to the Dirty Bilge tank.

The ER Port engine room bilge well, in addition, receives possible overflow from the sludge tank and miscellaneous fresh water leakage/overflow from the engine room systems. The Aft bilge well receives overflow from the stern tube LO sump tank.

The bilge wells cascade into one another as the bilge fills and overflows. Should all bilge wells be full the level continues to rise on the tank-tops. Visual indication is given as well as the level on the tank-top.

When the Bilge Water pump is in automatic operation it works on any of the bilge wells. If the Bilge Water pump is on for an excessive time an alarm will sound to indicate that there is a serious leakage.

#### Sludge tank

The sludge tank receives drains from the following sources:

- HFO purifier sludge
- DO purifier sludge
- LO purifier sludge
- HFO settling tanks drains
- HFO service tank drain
- DO service tank drain

The total water and oil input flows are summed up and oil / water interface level is displayed as well as total level.

Oily return flow from the bilge water separator also enters the sludge tank.

Sludge can be discharged from the sludge tank to the incinerator or to a shore reception facility.

#### Incinerator

The incinerator takes suction from the oil (top) part of the sludge tank by means of a float device. To initiate incinerator operation, start the pump and ignite the burner. If the pump light begins to flash, this flashing indicates automatic stop of the pump. Auto stop can be caused by:

- No oil in the sludge tank
- Time out for burner ignition

Flashing burner light indicates that the burner is ready for ignition.



---

**Operation.**

**1. Incinerator operation**

- 1.1 Note amount of oil in sludge tank
- 1.2 Open valve from sludge tank to burner pump.
- 1.3 Open valve to incinerator.
- 1.4 Start incinerator by pushing flame ON.
- 1.5 Incinerator will automatically stop at low level in sludge tank.
- 1.6 Note and record amount of sludge incinerated.

**NOTE.** The incinerator should only be used during sea passage.

**2. Sludge to shore**

- 2.1 Check that shore connection has been established.
- 2.2 Note amount of sludge in tank.
- 2.3 Open valve for discharge sludge ashore.
- 2.4 Start shore pump
- 2.5 Close discharge valve before removing the shore connection.
- 2.6 Note and record amount of sludge discharged.

**NOTE:** Before discharge to shore remote stop of the shore pump from deck location must be tested.



<This page is intentionally left blank>

00:02:25 Running	Picture MD 63	<b>Bilge Water Separator</b>	Alarms	?
			Silence	

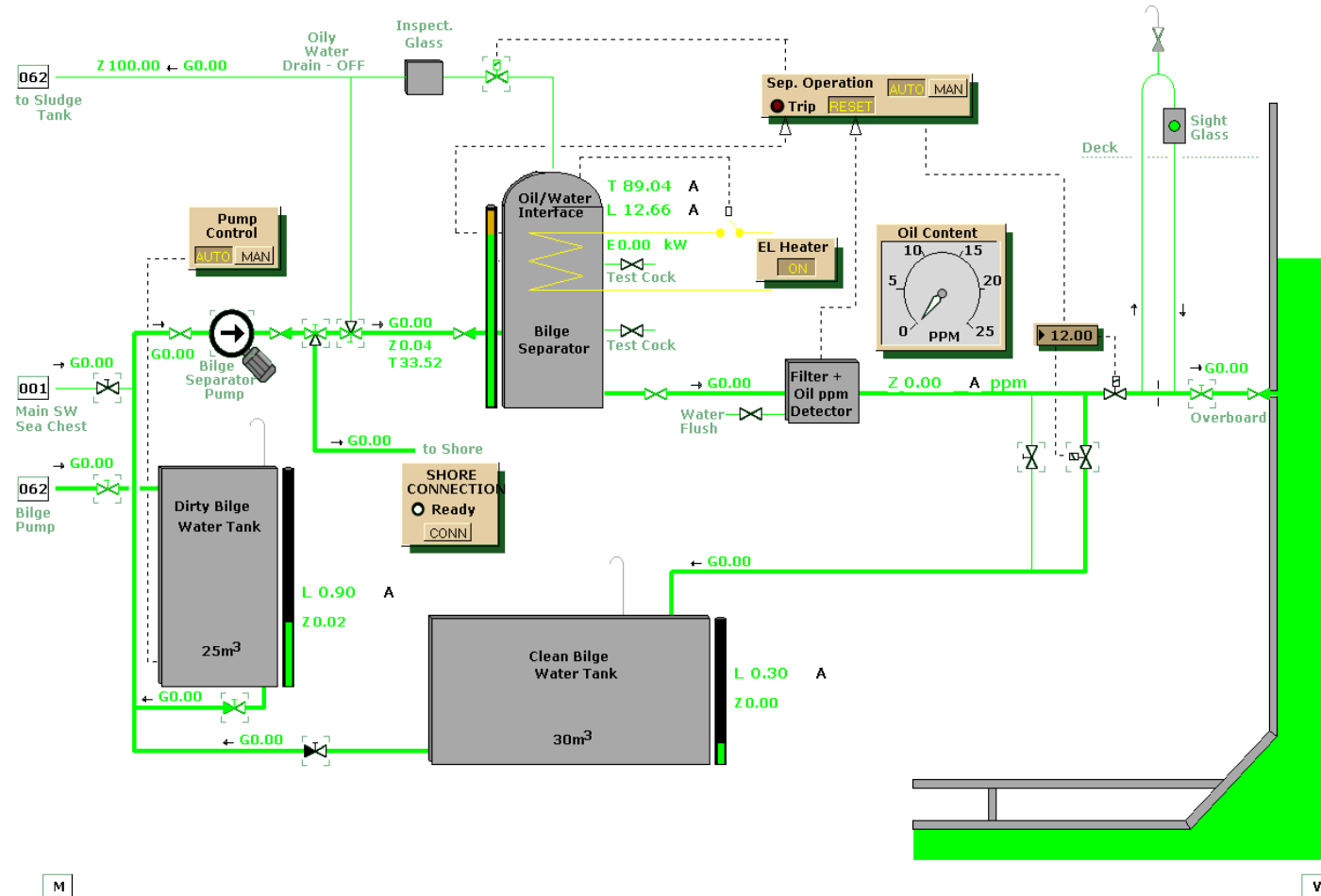

ERS - MC90-V 2.2.9999.0353 (01)

Unit Conversion	Message Log		Process Directory	Panel Directory	Process Overview	Back	Forward
-----------------	-------------	--	-------------------	-----------------	------------------	------	---------



### 5.14.2 Bilge Separator MD63

#### General

The separator is provided to eliminate engine room bilge water in accordance with current pollution prevention regulations by discharging water containing no more than 15 ppm of oil overboard.

The bilge separator separates oily water taken from the Dirty Bilge Water tank. Clean water is pumped overboard or to the clean water bilge tank, while the oil is returned to the sludge tank.

The separator unit consists of a tank divided into several zones by internal baffles. A positive displacement bilge pump supplies unprocessed oil/water downstream into the separator and simultaneously discharge treated water out of the separator.

As the oil/water mixture flows through the separator, oil droplets are attracted to the coalescer beads while water is repelled under the influence of gravity and heat. Water passes around the beads but oil temporarily attaches to them. Oil droplets accumulate on the beads until they become large enough to break away and float to the top of the separator.

Meanwhile, the treated water is discharged from the bottom of the separator, through the oil content monitor and then either overboard or to the Clean Bilge Tank, depending on residual oil content. Effluent will only be discharged overboard when its oil content is less than 15 ppm.

Eventually the oil layer at the top of the separator increases sufficiently to trip a sensor which causes the separator drain solenoid to open. The accumulated oil is forced out through the oil discharge valve to the sludge tank.

If the separator is operated in “AUTO” mode, the following functions are automatic:

- The overboard valve is closed and the re-circulation valve opened if the ppm limit in the overboard water is above a pre-set limit.
- If the oil/water interface sensor detects low level (much oil), the sludge valve is opened.
- The bilge separator pump may be started/stopped automatically according to the Clean Bilge Water tank level.

A flashing AUTO light indicates functional failure. The cause can be high oil content (low-low oil/water interface level) or low separator temperature. The separator pump will then be stopped, the sludge valve opened and the overboard and re-circulation valves closed.

The heating power is turned on/off according to temperature, by a thermostatic switch as long as the main switch is on. This switch works independently of the AUTO mode.



## Operation procedure

### 1. Preparation of bilge separator

- 1.1 START electric heating of bilge separator and set separator operation in MANUAL
- 1.2 Set the separator into AUTO mode when sufficient temperature (50°C)
- 1.3 Check the setting of the ppm detector.

### 2. Automatic or manual operation of the separator

- 2.1 Normally the separator is operated in AUTO. In Auto the valves for bilge over board, bilge re-circulation to clean bilge tank and sludge drain from separator to sludge tank are automatic controlled.

### 3. Daily service bilge from engine rooms.

- 3.1 Check oil content in bilge well.
- 3.2 Open suction valve from bilge well.
- 3.3 Open valve to Dirty Bilge Water tank.
- 3.4 Start bilge pump in manual.  
Monitor Dirty Bilge Water tank to prevent overflow
- 3.5 Record bilge transfer in Oil Record Book.

### 4. Automatic bilge from engine room bilge well.

- 4.1 If AUTO bilge pump control is active, the bilge suction valve from the engine bilge and the bilge pump will be activated according to the level in the bilge.
- 4.2 The filling valve for the Dirty Bilge Water tank must be open
- 4.3 If the bilge pump is ON for more than 20% (adjustable) of the OFF time an alarm is activated. Immediate action must be taken.
- 4.4 If Bilge Separator pump is in AUTO the two three way valves on the discharge must be aligned to the separator. The Dirty Bilge Water tank suction valve must be open.
- 4.5 The Bilge Separator pump will start and stop depending on the level in the Dirty Bilge Water tank.

### 5. Emptying bilge tanks.

- 5.1 Check and note down time and ship's position.
- 5.2 Check that bilge separator is ready.
- 5.3 Open suction valve from dirty / clean bilge tank
- 5.4 Open discharge over board
- 5.5 Check that bilge separator is in Auto.
- 5.6 Start bilge pump
- 5.7 Observe PPM-meter to avoid pumping oil overboard
- 5.8 Check and note down time and ship's position when finished.
- 5.9 Complete Oil Record Book.



## 6 Stopping Bilge Separator

- 6.1 Ensure operation is in manual mode.
- 6.2 Close Bilge Separator pump tank suction valve and open sea suction to flush separator.
- 6.3 Manually open Sludge valve to remove recovered oil.
- 6.4 Stop pump and close sea suction and overboard valves.

## 7 Bilge to shore

- 7.1 Check that shore connection has been established.
- 7.2 Note amount of bilge water in tank.
- 7.3 Open valves for bilge tank and discharge bilge ashore.
- 7.4 Start bilge pump
- 7.5 Close all valves before removing the shore connection.
- 7.6 Note and record amount of bilge discharged in Oil Record Book.

**NOTE:** Before discharge to shore remote stop of the bilge pump from deck location must be tested.

## Model particulars

- A small amount of oil and water is constantly leaking into the bilge wells (from unspecified sources).
- The content of the sludge tank is assumed to separate immediately into oil and water.
- The settling process in the separator vessel is modelled to be dependent on settling time, inlet flow oil content, temperature and position of oil/water interface level.
- Shore connection can only be activated if ship is in “mooring condition” (VP 9200, X07005=1)

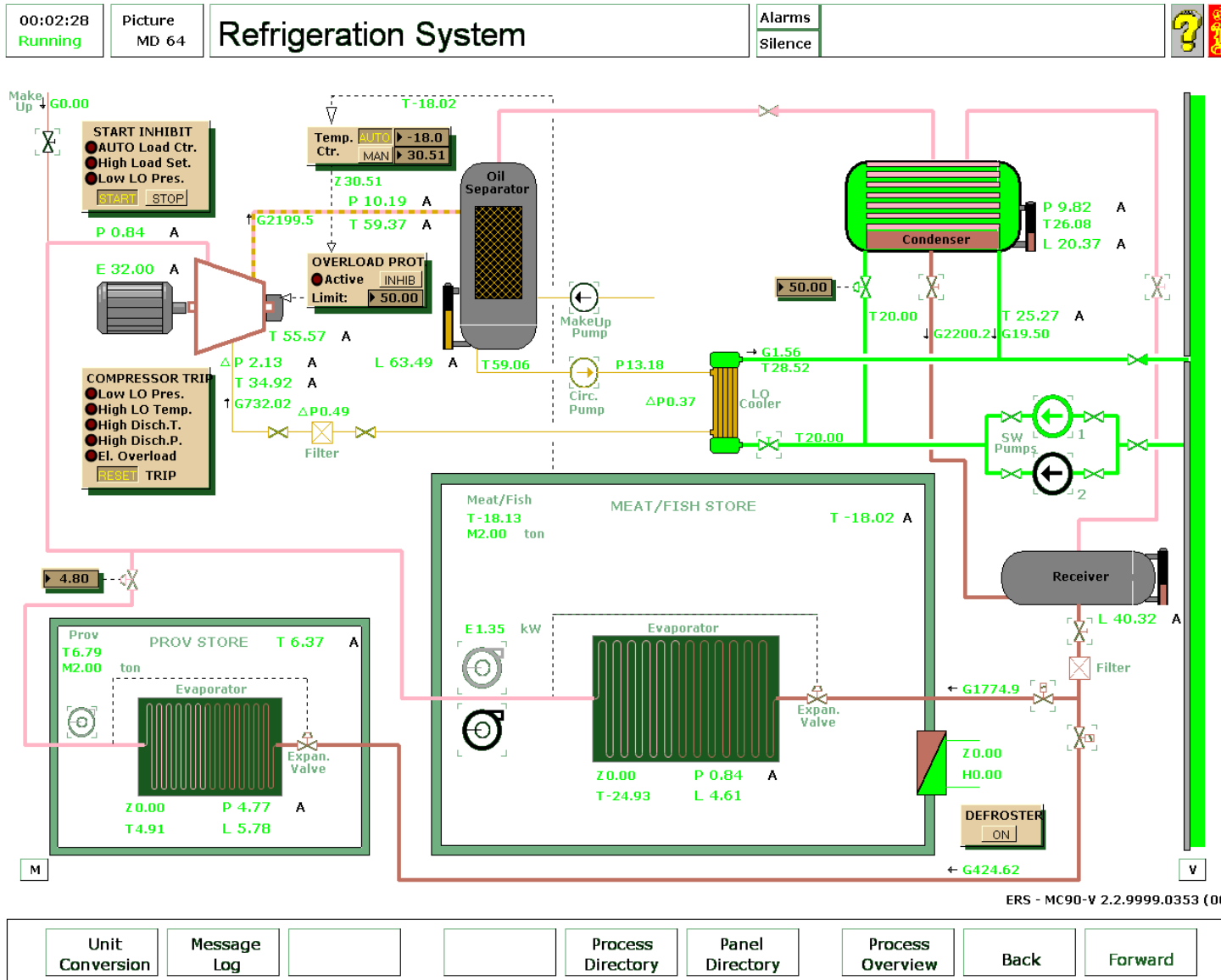

## 5.15 Refrigeration System MD64

### General

The refrigeration plant is based on R22 and consists of the following main components:

- Electrically driven screw compressor
- Compressor lubrication oil recovery system
- Sea water cooled condenser
- Refrigerant liquid receiver

Nominal capacities are as follows:

Cooling capacity:	110 kW at - 18°C/30°C
Screw compressor motor:	50kW (67hp)
Refrigerant flow:	0.6 kg/sec
Sea water cooling flow:	20 t/h

The plant comprises following compartments:

One Meat/Fish compartment (-18 °C) including:

- One 4 kW air fan for cooling down
- One 1.5 kW air fan for normal operation
- One evaporator with dry expansion
- Evaporator electrical defrost device

One provision store compartment for perishable goods (+5°C) including:

- One air fan
- One evaporator with dry expansion
- One evaporator pressure controller

### Description

The compressor is lubricated and cooled by oil and refrigerant gases. The lubrication oil is separated from the compressed refrigerant gas in the oil separator. The bottom part of the separator serves as an oil reservoir. If the oil level is less than 20% of full, new oil must be added.

A substantial part of the compressor heat is transferred to the cooling oil in the compressor screw, and the oil must be cooled. This is done by sea water in the lubricating oil cooler.

The electric compressor motor load varies according to compressor condition, suction pressure, discharge pressure and gas flow. Electric overload will occur if the load is higher than a pre-set adjustable limit.

The effective (internal) compression ratio and thus the compressor capacity of the screw compressor is adjusted by means of a suction slide valve. It is positioned by a PID controller, controlled by the Meat/Fish store temperature.

The sea water flow to the condenser is supplied by two sea water pumps. Normally just one is in operation, while the other is stand-by. The sea water flow can be adjusted by a throttle valve at the condenser inlet. Normally 50% valve setting is used, giving a flow of approx. 20 ton/h.



The condensed refrigerant flows by gravity to the liquid receiver. The valve called "vapour valve" is for pressure equalising between condenser and the liquid receiver vessel. If it is closed, the draining of the condenser will be obstructed.

The temperature of the Meat/Fish store is regulated by the compressor load while the Provision store temperature is set by the position of the evaporator pressure regulator valve.

### Operation procedure

#### 1. Preparation

- 1.1 Line up valves in the lubrication oil system and start the pump. Check and if necessary, refill the lubrication oil by means of the make-up pump.
- 1.2 Open vapour and liquid valves between condenser and receiver.
- 1.3 Open sea water cooling valves to lubrication oil cooler and condenser and start sea water pump.
- 1.4 Condenser cooling water control valve must be set to a suitable level to maintain appropriate condensation pressure.

#### 2. Starting

- 2.1 Open the liquid valves from receiver to evaporators.
- 2.2 Start forced draft fans in compartments.
- 2.3 Reset the trip functions if any present and start the compressor.
- 2.4 Set temperature control into MAN and adjust capacity control slide valve to 10%, (otherwise compressor will trip on overload).

- 2.5 Gradually increase compressor capacity manually checking the compressor electric power consumption during cooling down.
- 2.6 Set temperature controller into AUTO when temperature in Meat/Fish store is below  $-10^{\circ}\text{C}$
- 2.7 Normal temperature in Meat/Fish store is  $-18^{\circ}\text{C}$ .
- 2.8 When Meat/Fish store temperature approaches  $-18^{\circ}\text{C}$  change to 1.5 kW fan.
- 2.9 Adjust Provision store evap. capacity regulator to maintain Provision store temperature at  $5^{\circ}\text{C}$ .

#### NOTE:

Start Inhibit functions:

- AUTO selected : X06615 = 1
- High controller setting : Z06616 > 26%
- Low lubricating oil Pressure: P06571 < 0.75 bar

#### Model particulars

Heat loss to surroundings is dependent on ambient temperature. At steady state condition this is the only heat load modelled, in addition to the air circulation power dissipation.

To enable more versatile steady state operations, an extra heat load can be activated. This "extra load" can be interpreted as a secondary brine system cooled by the circulating air. The load setting represents the rate of flow circulation on the brine side. The additional heat flow is computed as being proportional to load setting and to the difference between the brine temperature ( $= 0^{\circ}\text{C}$ ) and refrigerated air temperature.



<This page is intentionally left blank>



## 5.16 Sewage Treatment MD 45

### Sewage Treatment Plant

Type: Biological oxidation and discharge

Capacity: 38 persons

One aeration compressor

One sludge pump

One effluent pump (discharge overboard)

One tablet chlorination dispenser

Sewage from the accommodation spaces flows through pipes, under the effect of a vacuum collection system, to the sewage treatment plant located in the machinery space.

The sewage treatment plant is a biological unit which works on the aerobic activated sludge principle. The plant will treat black and grey water and is fully automatic in operation.

This sewage treatment plant consists of a tank with three main compartments:

- Aeration compartment
- Settling tank (clarification) compartment
- Chlorination and discharge compartment

### Aeration tank

The sewage in this compartment is from the lavatory pans, urinals and hospital in the accommodation spaces. The incoming effluent material mixes with the activated sludge already present in this compartment. Air is supplied by means air pipes and distributed through the tank by aerators. The gas produced during the bacterial action which takes place is vented to atmosphere. Oxygen is

essential for the aerobic activity. The organisms require oxygen for digesting the raw sewage and it also assists in mixing the incoming sewage with the water, sewage sludge and bacteria already present in the compartment.

A screen at the outlet from the aeration compartment prevents the passage of inorganic solids to this compartment.

### Settling tank

The mixed fluid passes into this compartment and settles out into sludge and liquid. The water passes into the treatment and discharge compartment, whilst the remaining sludge, which contains the active bacteria, returns to the aeration compartment by means of an air lift tube for further processing. The surface is skimmed of detritus which is returned it to the aeration compartment.

### Chlorination and Discharge tank

Water from the clarification section is mixed with disinfectants (sodium hypochlorite) and is sterilised. The compartment has float operated switches which activate the effluent pump (discharge) when the high level is reached and stop the pump when the compartment is nearly empty. Chemical dosing is by means of tablets added to the basket in the chamber and these dissolve slowly when in contact with the water in the chamber as the water level rises.



## CAUTION

**Discharge overboard of untreated sewage should not take place within 12 nautical miles of the coast and local restriction concerning treated sewage discharge must be strictly observed.**

The sewage treatment plant works automatically once it is set but periodic attention is required and the unit must be monitored for correct operation.

(**Note:** Rules governing the discharge of raw sewage must be complied with at all times and the discharge of raw sewage overboard must only be contemplated should the sewage plant be out of service. The bacterial action requires a regular supply of raw sewage and the discharge of raw sewage overboard can impair effective bacterial action.)

### Operating the Sewage Treatment Plant

There is a black water supply from the vacuum collection system and a grey waterline supply from the galley and laundry system. In both supply lines there is a control valve.

The effluent pump has a direct connection to the overboard discharge line.

Set the system valves as in the following table:

- Open overboard valves in the discharge line from the effluent pump
- Open suction valve from chlorination tank
- Close suction valve from settling tank
- Close suction valve from aeration tank
- The sewage treatment unit should be initially filled with water

- Activated sludge shall be added if it has been emptied for any reason or when commissioning the plant for the first time. This will not be required when the unit has been operating previously but the description is included for completeness.
- Check that effluent pump is selected for operation.
- Check that dosing chemical tablets have been added to the basket in the discharge chamber.
- The sludge and the effluent pumps are set in “auto” mode.
- Open diffuser and air lift valves
- Start the aeration compressor.
- Set the UV radiation unit on.
- Start to supply the unit with black/grey water.
- Operate the unit to maintain output levels within Marpol IV requirements.

At high level in the chlorination tank, the bypass valve will open across the UV radiation unit.

### 1 Operation in local restriction areas

- 1.1 Open the valve to the sewage sludge tank
- 1.2 Close the valve before the UV unit.

<This page is intentionally left blank>

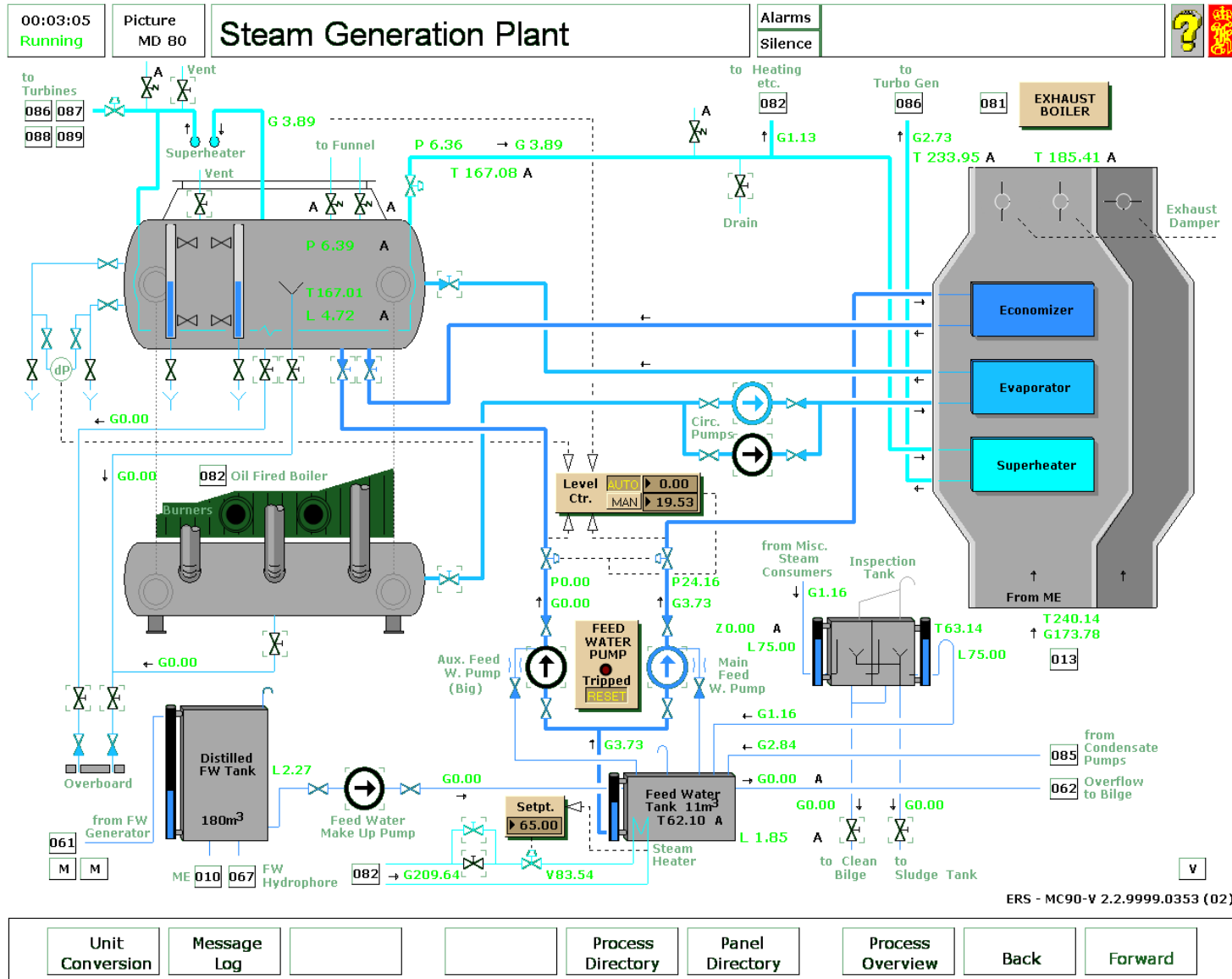

## 5.17 Steam Generation Plant MD80

### General

There is an oil fired (OF) water-tube boiler for port and cargo pumping duties, and an exhaust gas boiler (EGB) for steam supply at sea. Feedwater for the OF boiler is supplied via the economiser section of the EGB at all times.

Water from the OF Boiler water drum is circulated through the EGB Evaporator section before being returned to the OF boiler steam drum. Saturated steam is passed through the superheater section of the EGB to supply the Turbo-alternator at sea.

There are two feed pumps (Main and Auxiliary) drawing from the feed tank which can be topped up by the Make-up feed pump from the Distilled Water tank. The auxiliary Feedwater pump is used only for high steam production (cargo pumping), as it has a capacity of 500% of the main feed water pump. Condensate returns directly to the Feed tank but other returns are via an Observation tank to prevent oil contamination. The screen will display the oil content within the inspection tank to indicate oil contamination of the condensate returns.

The water level in the steam drum is controlled by a PID level controller, driving the two feed water control valves in parallel from a common I/P converter.

Both feed water pumps trip at high-high steam drum water level to protect steam consumers from “water strike” caused by water in the outlet steam.

The heat transfer in the exhaust boiler is controlled by exhaust dampers which by-pass some of the exhaust from the main engine. The exhaust damper position is automatically set by a PID controller thus controlling the steam pressure.

The condensate from heating and miscellaneous service application returns to a condensate filter/inspection tank and then flows back to the feed water tank. The condensate from the condenser is pumped directly to the feed water tank.

The feed water tank and the filter/inspection tank are modelled with heat loss to the surroundings. They will therefore gradually cool down if the inlet flows are stopped.

The temperature of the condensate entering the inspection tank is assumed to have a constant value (80°C).

The system is designed to operate in two distinctive modes:

- a) Cargo pumping (in port use)  
The oil fired boiler operates at a steam pressure of 16 or 7 bar (high or low setting). Steam is supplied to the four cargo pump turbines, and ballast pump turbine, with a total output capacity of 40 tonne/hour.
- b) Turbo generator operation (at sea use)  
When the ME is running, the waste heat in the exhaust gas is used to generate steam, between 7 and 9 bar. The minimum pressure of 7 bar can be maintained by automatic



operation of the oil fired boiler if required, whilst the exhaust damper control will limit the maximum pressure to 12 bar.

If the oil-fired boiler or exhaust boilers are dirty they must be cleaned (“sootblowing”). Saturated steam is used to sootblow the oil-fired boiler and service air sootblows the exhaust boiler.

The exhaust boiler sootblowing equipment represents a very heavy load on the service air system when in operation.



<This page is intentionally left blank>

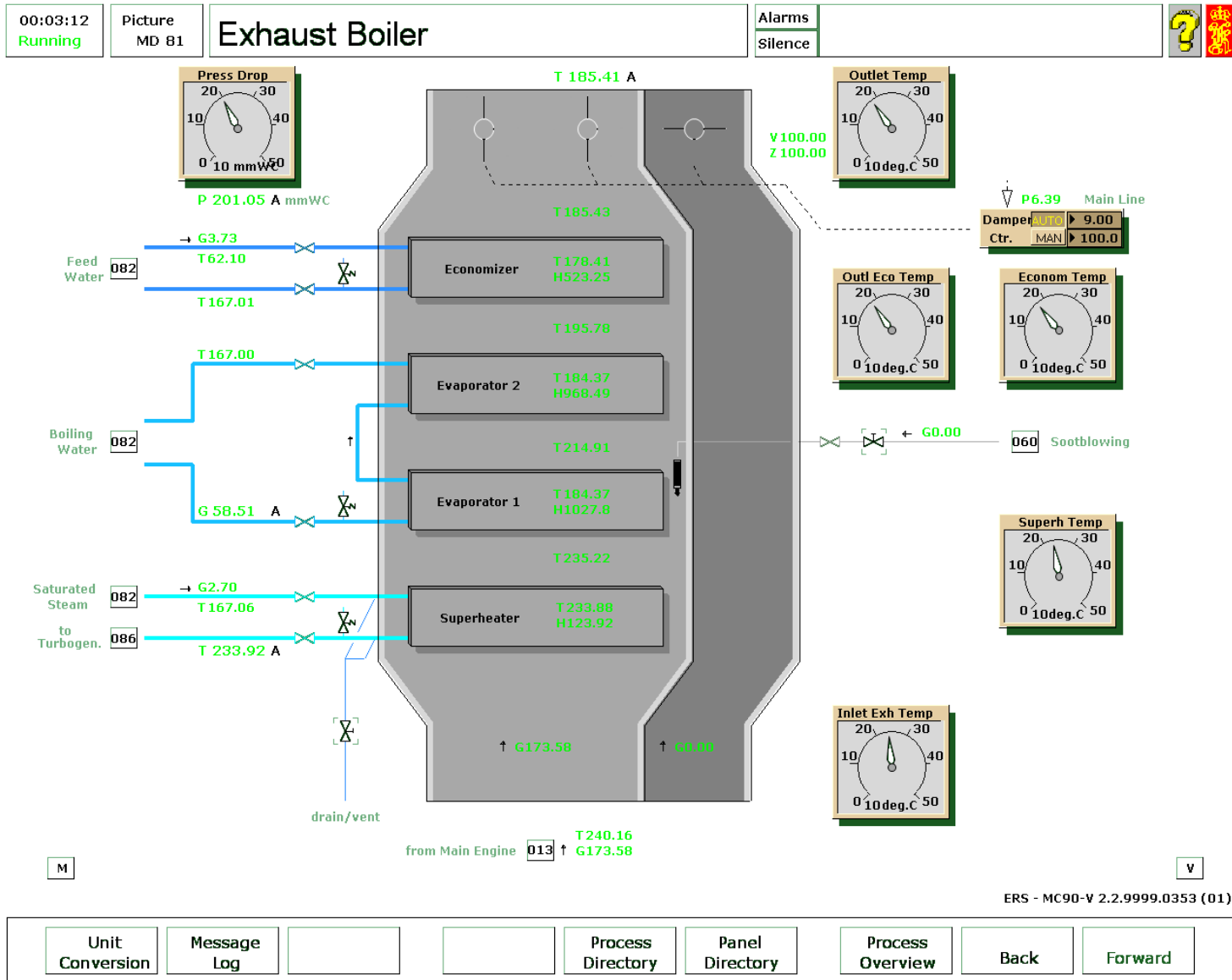

## 5.18 Exhaust Boiler MD81

### General

The Exhaust Gas Boiler consists of two ducts through which the exhaust gases from the main engine passes. One duct contains four banks of heat exchanger tubes, the other is plain to bypass the heat exchangers. Dampers control of the exhaust gas flow path, and the damper position is regulating by the PID controller from a steam pressure input

The top bank of tubes is the economiser section where the feedwater passes through the tubes counter to the gas flow.

The next two banks are the evaporation section and the water from the oil fired boiler water drum enters the lower header of the lower bank and passes parallel to the gas flow collecting heat. The steam/water emulsion leaves via the upper header of the upper bank and returns to the steam drum of the oil fired boiler.

The lower bank of tubes is the superheater section where the saturated steam from the oil fired boiler passes in via the upper header of the bank and counter to the gas flow to out of the lower header to the turbo-alternator, cargo pumps and ballast pump. The superheater is fitted with a combined vent and drain valve.

There is a Sootblower fitted for cleaning purposes which uses air as the operating medium from the service air system.

### Operation

The Economiser section will be put into operation once the OF Boiler main feed system is in use.

The Evaporator section is started up once the OF Boiler Feed system is in use by:

1. Opening Boiler Circ pump outlet valve and Boiler circ pump inlet valve on the boiler water and steam drums
2. Starting one of the two circulating pumps
3. Place the circulating pumps on auto to provide standby operation.

### Sootblowing

1. Observe differential pressure across EGB
2. Inform bridge of sootblowing operations – bridge should ensure that deposits do not land on the vessel
3. Ensure that service air is supplied from main air receivers
4. Open sootblowing valve.
5. After sootblowing observe differential pressure to gauge effectiveness.

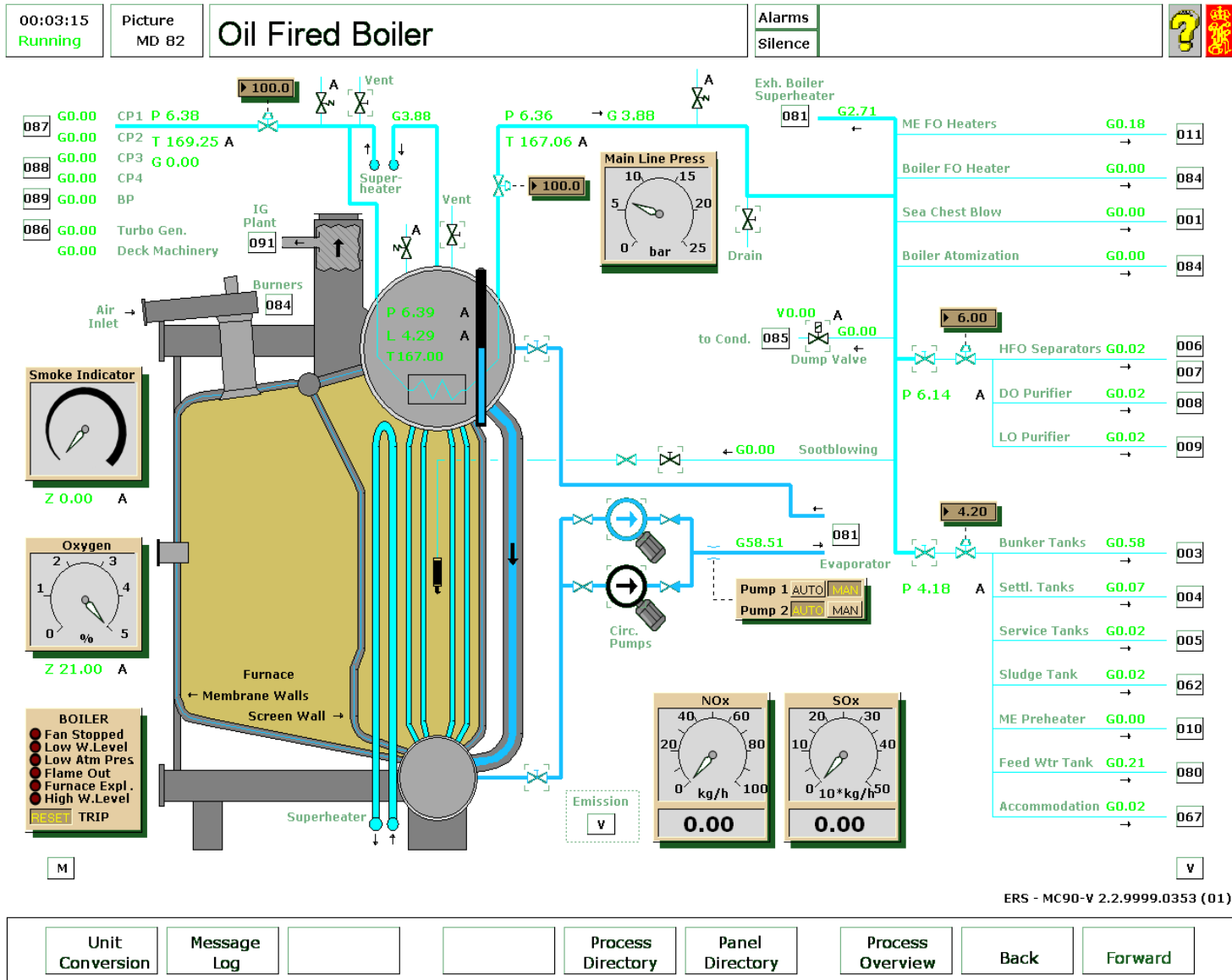

## 5.19 Oil Fired Boiler MD82

### General

This has two oil fired burners fitted in the roof of the boiler. The furnace is of membrane wall construction except where the single bank of inverted U-tubes forming the superheater. The superheater is protected from the main flames by a screen row of tubes from the water drum to a header leading to the steam drum. After the superheater is a bank of generating tubes running between the two drums.

Connecting the steam and water drums are unheated downcomers to promote circulation.

A de-superheater is fitted within the steam drum to provide saturated steam flow for the heating loads shown on this screen. This will ensure that there is a positive flow of steam through the superheater at all times, and should prevent excessive superheater metal temperatures that could lead to superheater failure.

A steam driven sootblower unit is fitted within the generating tube bank to ensure that the heating surfaces are kept clean.

Saturated steam from the drum supplies heating services in port and heating services and EGB superheater at sea. Superheated steam supplies the Cargo/Ballast pumps, Turbo alternator, and Deck machinery.

A vent is provided on the steam drum to vent air from the boiler during start-up, and to ensure that the steam drum does not allow a vacuum to form during shut-down periods.

To provide a lower heat source to the separators and purifiers, a pressure reducing valve is fitted. This valve should ensure that the steam temperature within these supplies is moderate, and below 160°C.

Fuel tanks, ME pre-heating, feed tank and accommodation are also supplied with reduced steam with temperature below 140°C.

A steam dumping facility is provided. When it is activated, the steam is dumped directly to the condenser, thus avoiding loss of feed water that would occur should the boiler safety valves lift. A flashing light and alarm indicates that dumping is activated. Steam dumping starts at approximately 17 bar.

### 5.19.1 Boiler Emission

A full survey of the simulated flue gas composition is displayed on model variable page MVP8206.

PM, particulate matter in flue gas, or “smoke” is indicated on a relative scale ranging from 0-100 %.

All other components are presented as mass flows, kg/h, or as specific mass ratios, g/kg fuel.



NO<sub>x</sub> represents the sum of nitrogen dioxide (NO<sub>2</sub>) and nitrogen monoxide (NO).

SO<sub>x</sub> represents all sulphur component, mainly sulphur dioxide (SO<sub>2</sub>) and some sulphur trioxide (SO<sub>3</sub>).

HC and CO, hydrocarbons and carbon monoxide, represent all residual unburned fuel components in the flue gas.

The computation of the flue gas composition is based on empirical constants and functions. The results must be regarded as indicative only.

#### Comments on flue gas emission

NO<sub>x</sub> generation increases with temperature and excess oxygen in furnace. Unevenly distributed air/fuel creates high local temperatures in the combustion zone and gives higher overall NO<sub>x</sub> values.

In the simulator the NO<sub>x</sub> can be seen to increase with boiler load (furnace temperature) and oxygen surplus in furnace (oxygen controller setting).

Atomizing steam to the burner cools the flame and reduces the NO<sub>x</sub> formation somewhat.

NO<sub>x</sub> reduction can generally be accomplished by:

- operating as close to stoichiometric combustion condition as possible.
- operating with homogenous, well-mixed fuel/air mixtures throughout the combustion zone
- operating through a two-stage combustion process to reduce peak flame temperatures:

stage one: a fuel rich zone with lack of air, stage two: a lean burning zone with some extra air added to complete combustion. This staged combustion reduces average flame temperatures and NO<sub>x</sub> generation.

The simulator offers three methods for demonstrating reduced NO<sub>x</sub> emissions:

#### Flue gas recirculation – FGR

In a given marine boiler with limited space available, the easiest way of reducing NO<sub>x</sub> is probably through flue gas recirculation. A flue gas duct from the stack to the air combustion air fan inlet is needed, some times separate flue gas recirculation fans are required.

In the FGR example recirculation rate of 15 % is assumed, giving a NO<sub>x</sub> reduction of approximately 30 %.

#### Tangentially fired boiler - TFB

Such boilers require much space and this pose a challenge to marine applications.

The boiler design offers good air/fuel mixing by cyclone action. Its well-mixed, homogenous combustion zone enables furnace operation at very low excess air values (down to 0.5 %).

The TFB example is assuming an “over-fire” air supply to obtain a two-stage combustion with fuel rich burning in stage 1 (in the lower boiler part) and air rich afterburning at reduced temperatures in stage 2 (upper boiler part).



Selective Catalytic Reduction – SCR

Effective NOx reductions can be achieved by a post treatment of the flue gas by adding ammonia (NH<sub>3</sub>) to the flue gas stream in a fixed bed catalyst vessel. The flue gas temperature level must be right, typically between 300 and 400 dgrC. The catalyst promotes a reaction between NOx and NH<sub>3</sub> to form nitrogen and water. NOx reductions as high as 90 % are achievable. Careful design of inlet mixing grid and control of the NH<sub>3</sub> dosage is necessary to keep ammonia emission (“NH<sub>3</sub>-slip”) to an acceptable level. The ammonia concentration in the flue gas should not be higher than a few ppm.

The ammonia requirement is in the order of 0.50 kg NH<sub>3</sub> per kg NOx reduced. Cleaning the flue gas of the simulator boiler would thus require an ammonia consumption of approximately 25 kg/h at high boiler load (fuel flow 3 ton/h).

Comment on CO/HC emission

The content of carbon monoxide (CO) and unburned hydrocarbons (HC) in the flue gas increase with decreasing excess air. When air-to-fuel ratios approach stoichiometric values both CO and HC emission increase dramatically. Tangentially fired boilers allow operation at a lower air-to-fuel ratio without excessive CO/HC/smoke, giving high boiler efficiency and reduced NOx values.

SOx generation

The SOx generation depends on the sulphur content in the fuel. In the simulator the sulphur content in the HFO and DO fuel can be

seen and changed on the fuel oil data page MVP1129. Default setting is 3.5 % sulphur in HFO and 0.5 sulphur in DO.

The slight increase in the SOx reading at high excess air settings is due to the fact that more SO<sub>3</sub> is formed at high oxygen concentrations.

The SOx is not affected by the NOx counteracting measures described earlier. The most efficient practical way of reducing sulphurous emission in maritime applications seems to be removing sulphur from the fuel oil in the refinery by chemical processing.

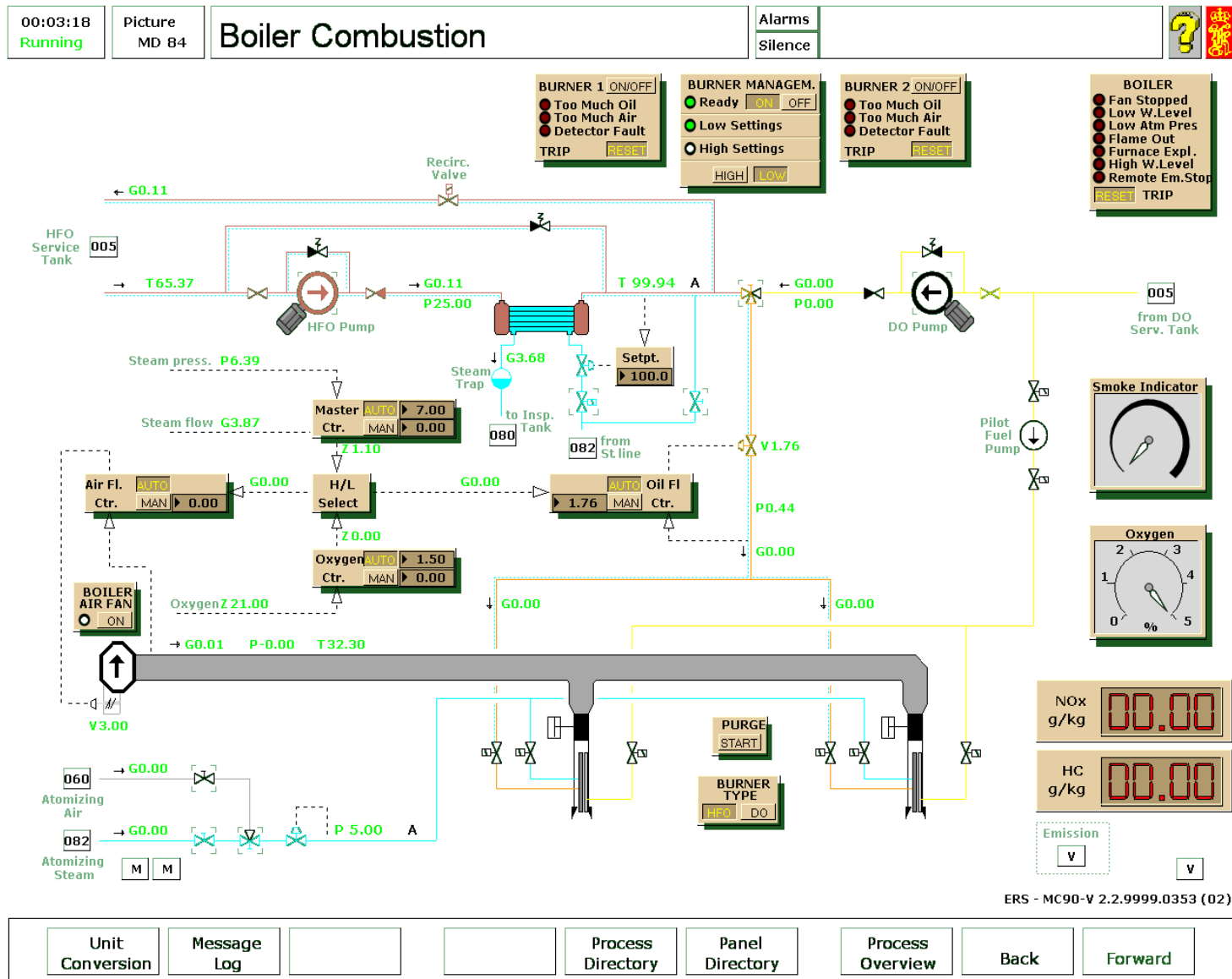



## 5.20 Boiler Combustion MD84

### General

The boiler has two registers fitted in the roof which can burn either diesel oil or heavy fuel oil, the burner being changed to suit.

Each fuel system has its own supply pump and the HFO system is fitted with a steam heater to condition the oil for combustion and a steam tracing system to assist in keeping the oil flowing. Atomising steam, or air, is provided to improve the combustion of the fuel. A diesel oil pilot burner is provided to ensure light-up of the main burner.

Air as well as steam for atomisation is provided, selection being made by change-over valve. Neither of which are allowed to operate when the DO burner is in use.

A burner management system is provided which operates the boiler at 8 bar on the low setting and 16 bar on the high setting.

A safety system cuts off the fuel oil supply to the boiler by closing the trip valve at the following conditions:

- stopped combustion air fan
- low steam drum water level
- low steam atomising pressure
- no flame indication, both burners
- no purge operation
- incorrect nozzle fitted
- high water level

The combustion control system consists of a master controller and two slave controllers, and also an oxygen controller. Its objectives are:

- to control the oil flow to the boiler to keep the steam pressure as close to the pressure set-point as possible.
- to supply correct amount of air relative to oil at any time to ensure efficient and safe combustion.
- to supply the correct amount of air to allow the inert gas system to operate at low oxygen levels

The master controller generates a signal to a “high/low” select logic box. This computes the set-points for the desired oil and air flow for the slave controllers. The master controller is a PID acting controller with feed forward from steam flow out of steam drum and feedback from the steam pressure.

The slave controllers are fully acting PID controllers. They must be set in manual mode during start-up.

The function of the “high/low” select logic is to ensure that air command increases before oil command at load increase and that oil command is reduced before air command at load reduction. This is a standard logic block found in most boiler control schemes, and will prevent excess smoke during load changes.



Before start-up of the boiler the furnace must be air purged. The purging period is set long enough to change the air volume in the furnace about 4 times in accordance with classification societies safety requirements.

The automatic lighting sequence is as follows:

- air register is opened to allow the boiler to be purged
- the pilot oil pump is started
- electric spark ignitor turned on
- the pilot oil valve is opened and the pilot flame should ignite (a small flame is displayed)
- main oil shut off valve opened
- atomising air/steam valve is opened (when in HFL operation)

If the flame detector does not see flame within approximately 6 seconds, the oil shut off valve and the air register are closed. The boiler will trip and will need to be manually reset.

When the burner is in operation the flame will be “blown out” if there is too much air compared to oil (alarm code will be too much air) and it will be difficult to ignite if there is too much oil compared to air (alarm code will be too much oil).

### **Burner Management**

The boiler system includes a simple but efficient burner control system. It starts and stops burner no 2 (slave burner) according to need. It is in function only if burner no 1 (base burner) is on.

The slave burner is started if the secondary steam pressure is under low limit and is stopped if the pressure is over high limit.

To avoid burner cycling (frequent start and stop of burners caused by the mutual influence between combustion control and burner management), there is a time delay between start and stop.

If a burner fault occurs, the burner is shut down and the “BURNER ON” light is flashing. The cause of a burner fault is found by inspecting the trip code:

- too much oil during ignition
- too much air during ignition
- unstable flame caused by lack of oil
- unstable flame caused by lack of air
- flame detector failure

The heavy fuel oil is taken from the common HFO service tank and heated in a fuel oil heater. Normal operating temperature is 90°C. If the heavy fuel oil gets colder than 80°C, the smoke content will increase because of poor oil atomisation. The burners will require more excess air for safe combustion.

Atomising steam is supplied from the steam system, and atomising air is supplied from the service air system. Both mediums pass through a pressure reduction valve. At atomising pressures lower than 3 bar the burners must be fired on diesel oil.

The diesel oil is taken from the common DO service tank and is pumped into the boiler’s fuel oil line by a separate DO pump.

Criteria to be fulfilled before Burner management is ready to be put in AUTO. These can be checked by clicking on the burner management icon.



- Boiler trip reset
- HFO selected (valve)
- Master controller auto
- Oil flow controller auto
- Air flow controller auto
- Atomising steam valve open
- HFO temp > 75°C
- Boiler pressure > 4 barg

Note that the boiler fan and HFO pump are automatically started at reduced ME power i.e. the exhaust boiler is not sufficient to maintain the steam pressure. When the exhaust boiler is maintaining the steam pressure at increased ME power (oil fired boiler is stopped), the fan and HFO pump must be stopped manually.

The feed forward signal to master controller:

Steam flow out (G05002\*C05510) and:

$$\text{(Steam flow out - feed water flow in) * constant =}$$
$$\text{(G05002-(G05011+G05012) * C05524}$$

All feed forward signals are individually adjustable. Can be switched off by setting the C-variable to zero (0).

**Error! Objects cannot be created from editing field codes.**

**Boiler operation**

Assuming that Electrical power is being supplied by one D/G and the Seawater/LTFW and Air Systems on line:

1. MD80; check the boiler water level is within normal working limits.
2. MD 82; open V05103 (boiler vent valve) and V05008 (super heater steam line vent valve).
3. MD 05; Open V00367 (DO to boiler), V00327 (HO to Boiler) and V00328 (HO Service Tank shutoff valve)
4. MD 84; Start the DO pump (R05634), change over V05654 (HFO/DO c/o Valve) to DO, select DO Burner (X05702)
5. MD84; Start the FD Fan (R05635).
6. MD84; Set the four controllers to manual, the master at 7, the fuel flow and oxygen controllers at 10.
7. MD84; The air flow should be set at 100 and the purge cycle initiated. When the purge cycle is complete (the purge indication releases) change the air flow controller value to 10.
8. MD84; Reset any boiler trip, and press burner 1 on/off button.
9. MD84; Pilot fuel pump should start and pilot flame appear at burner followed after a few seconds by the main flame.
10. MD84. Pressure should now be raised according to standard boiler practice according to the scenario conditions selected. The following sequence will bring the boiler on-line within one hour :-
11. MD84; Decrease the airflow controller to 1 and decrease the fuel controller value to 4. Allowing the burner to fire continuously, go to MD82.
12. MD 82; when steam drum temp > 105° C (drum pressure over = 0.23bar) shut Boiler Vent Valve (V05103) & Super heated steam line vent valve (V5008).
13. MD82; open V05378 (steam line drain).
14. MD82; Fully (100%) open main shut off Valve (V05108)
15. MD 84; Open V05653 (Boiler FO heater shut off valve) and V05668 (Boiler steam tracing valve),
16. MD84; Start the HFO Pump (R05633).
17. MD84; Open V05640 (Atomising steam valve ).
18. MD 80; When the main steam line pressure rises to 1.0, shut steam line drain (V05378).
19. MD80; When the level in the steam drum drops below -10, open Boiler Main feed valve (V04807), put Feed controller in MAN and start the Main feed pump (R05630). Adjust the MAN output to 10%.
20. MD80; Raise the water level to + 75 and stop the pump. Monitor the water level and repeat this operation as necessary when the level drops below – 75.
21. MD 84; When the boiler pressure reaches 8 bar the “low atomising steam pressure” and ‘HFO low temp’ alarms should reset. When alarms have reset, switch No 1 burner off at on/off button.
22. MD84; Change over HFO/DO c/o Valve (V0654) to HFO and the Burner type to HFO.
23. MD84; Put airflow, Fuel flow and oxygen controllers in AUTO and then finally put the Master controller in AUTO.
24. MD84; Reset the boiler Trip - Burner management “ready” light should illuminate, so now switch it on.
25. MD84; Stop D.O.pump, as the boiler is now operating in HFO mode.
26. MD 80; The Main feed pump (R05630) should now be started and left running.

27. The boiler will now operate in automatic mode at either the low setting (for 8 bar operation at sea), or the high setting (for 13 bar operation for cargo operations)

**Oil Fired Boiler Level Control**

The performance of the water control loop is largely dependent on whether the main or the auxiliary feed water pump/control valve is in operation, and on valve and pump characteristics.

When the water is supplied through the auxiliary line there will be no preheating of the water and a drop in steam pressure will occur if the cold feed water flow increases rapidly. A reduction in steam pressure tends to increase the feed water flow even more, due to the increased differential pressure across the feed valve.

There is therefore a mutual disturbing interaction between the combustion control and the water level control system. The water flow influences the steam pressure and the steam pressure the water flow.

The “three-point” level control includes the feed forward signal from the difference between steam flow (outlet steam drum) and feed water flow (total). This control reduces the sensitivity to the disturbance set up by varying steam pressure, and to conditions like mismatched control valve (flow characteristic/hysteresis) or oversized feed water pump.

It is of vital importance that the steam pressure is steady when the level controller is adjusted. It is therefore recommended that the master combustion controller is set to MANUAL during level

control trimming. This “breaks” the mutual interaction between pressure and level control.

Oil Fired Boiler Level Control

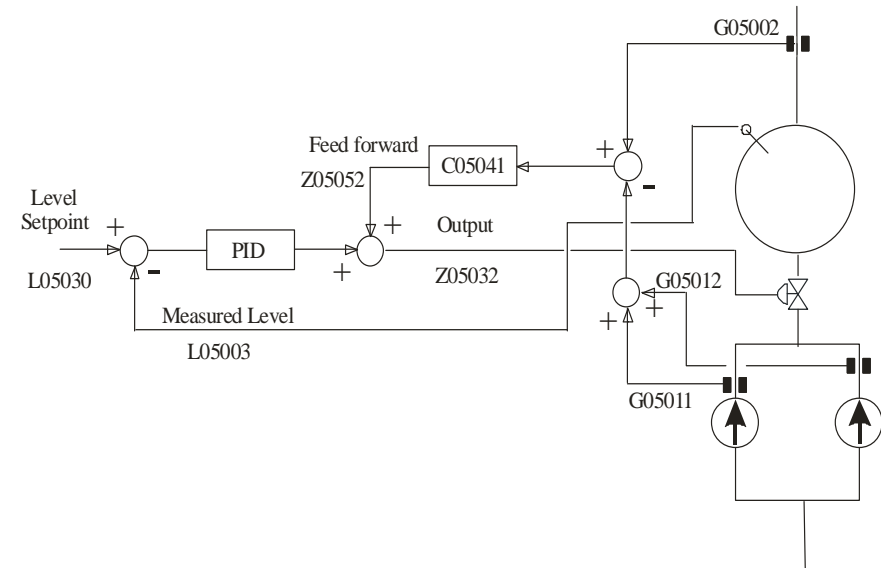

Feed forward:

$$Z05052 = (\text{steam flow out} - \text{feed water flow in}) * C05041$$

The feed forward signal is switched off when setting C05041 to zero (0).

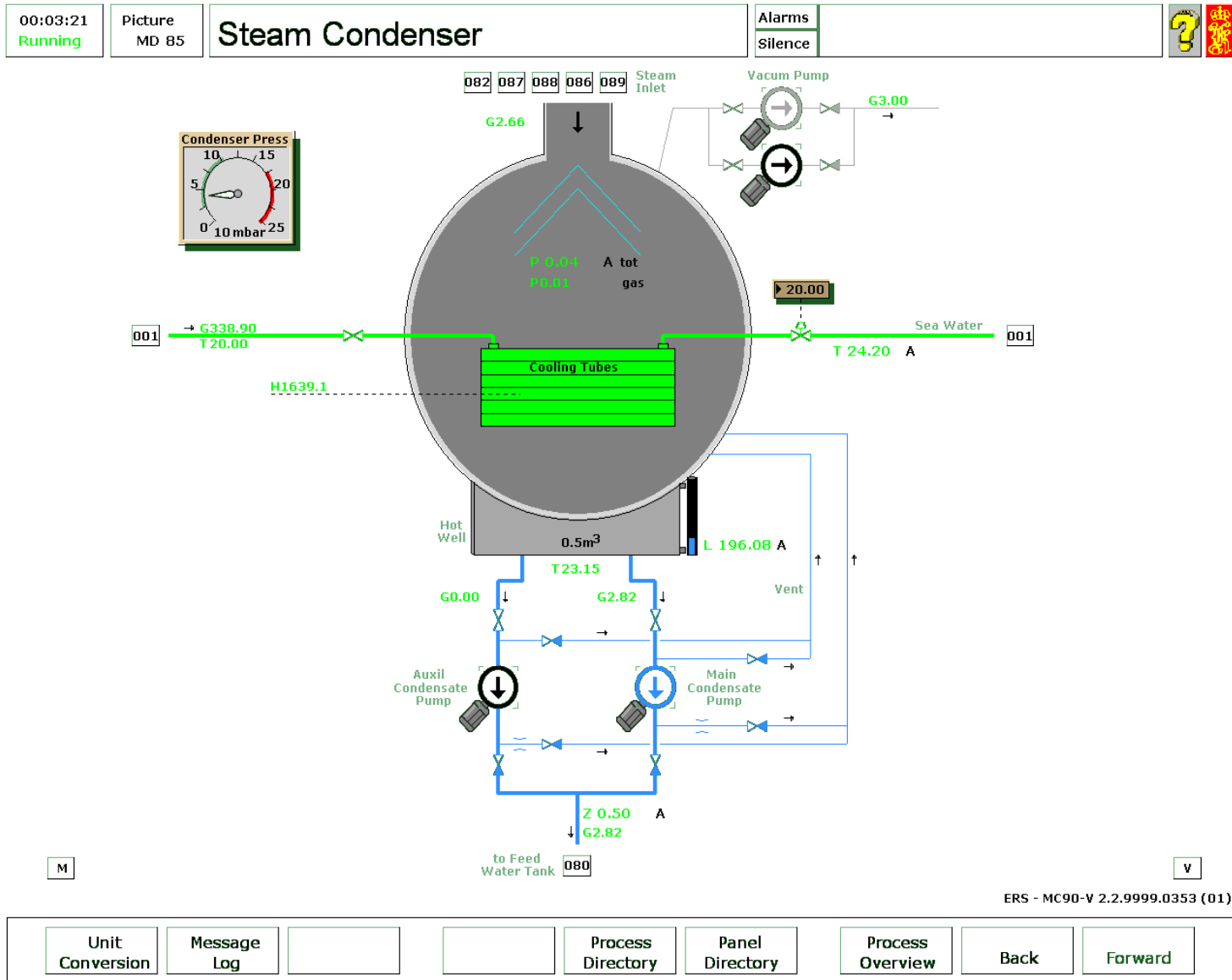

## 5.21 Steam Condenser MD85

### General

The steam condenser is used to cool the exhausting steam from the

- Dump valve
- Turbo generator
- Cargo pump turbines
- Ballast pump turbine

The Steam condenser is seawater cooled with a flow adjusting valve on the inlet. This can be utilised when optimising the operation of the plant.

To improve plant performance, the condenser is operated in vacuum conditions. The vacuum is created and maintained by the two vacuum pumps, of which only one of which required at one time. The pressure in the condenser shell can be regarded as composed by two components; vapour pressure and pressure from non condensable gases. The vapour pressure depends on the total steam flow to the condenser, the sea water flow and the sea water temperature. When the vacuum pump is stopped, the gas pressure will gradually increase and the total pressure slowly moves towards atmospheric pressure.

The air leakage increases strongly if the sealing steam on the turbo-alternator is not pressurised. The outlet valves of the cargo turbines should be closed when not in operation to stop air leakage from cargo turbine glands.

Condensate from the condenser is held in the hotwell, beneath the condenser tubes. Extraction from this hotwell is provided by the condensate pumps. A main condensate pump is provided for low duty and an auxiliary pump for high load duties although during periods of ultra high load both may be required to maintain the condensate level in the condenser. The pumps are modelled as “cavitation” pumps and the delivery increases strongly with hot well level. A separate level control system is therefore not required.

00:03:25 Running	Picture MD 86	<b>Turbo Generator</b>	Alarms	?
			Silence	

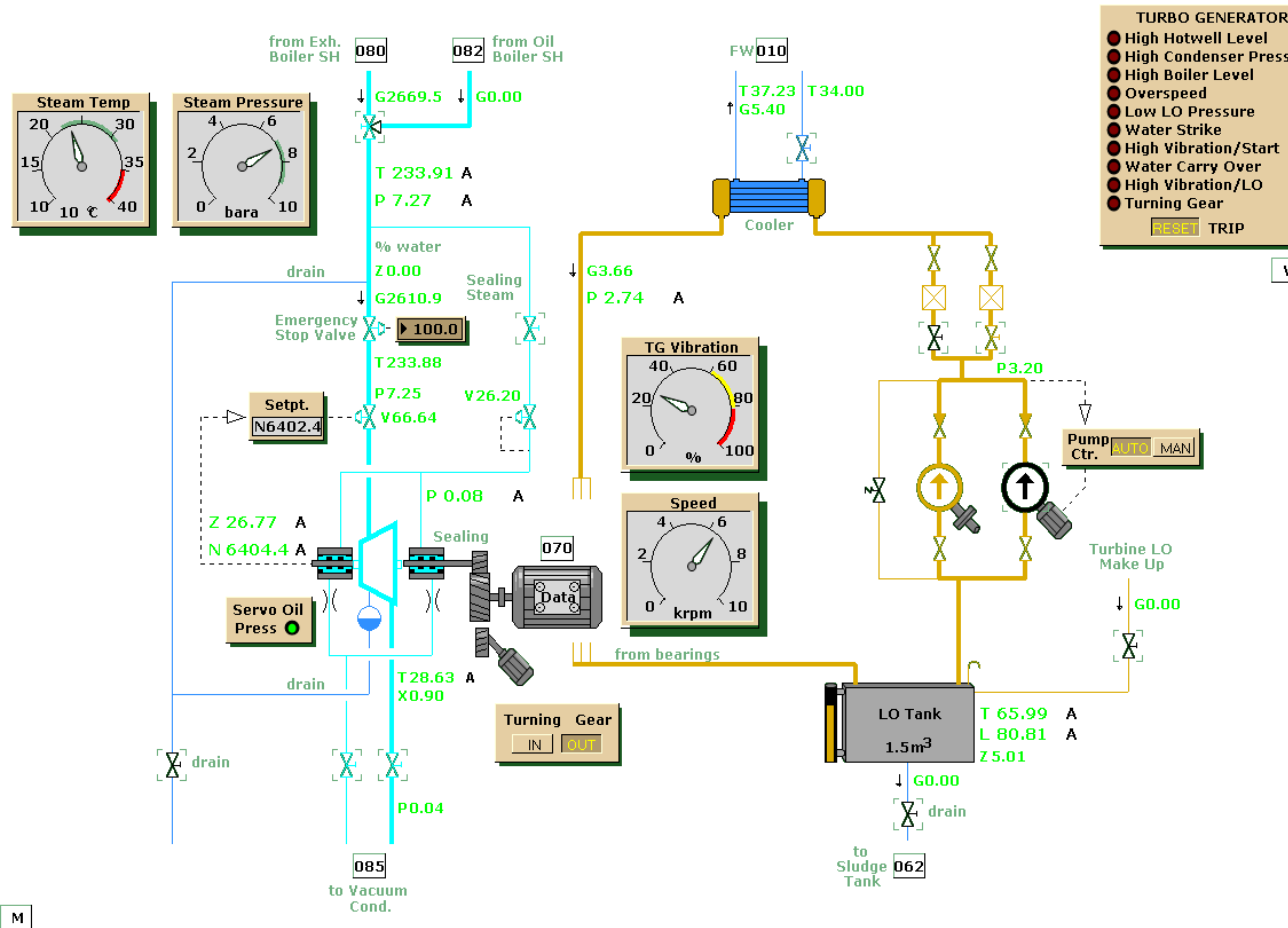

- TURBO GENERATOR**
- High Hotwell Level
  - High Condenser Press
  - High Boiler Level
  - Overspeed
  - Low LO Pressure
  - Water Strike
  - High Vibration/Start
  - Water Carry Over
  - High Vibration/LO
  - Turning Gear
- RESET TRIP

M V 144

ERS - MC90-V 2.2.9999.0353 (01)

Unit Conversion	Message Log		Process Directory	Panel Directory	Process Overview	Back	Forward
-----------------	-------------	--	-------------------	-----------------	------------------	------	---------



## 5.22 Turbo Generator MD86

### General

A 900kW turbo-generator is fitted for use at sea with steam supply from the exhaust gas boiler. In port it can also be supplied from the oil fired boiler on the low setting. There is a change-over valve fitted in the inlet line.

The turbo-generator is fed with superheated steam from the exhaust boiler. The exhaust fired boiler produces steam of 9 bar and superheated to approx. 240°C.

The turbine is modelled realistically with torque dependent on steam flow, inlet steam pressure/temperature and condenser vacuum. The throttle valve is controlled by a speed governor. The speed can be remotely adjusted by lower/raise signals from the electric switch board, or the manual set-point adjustment at the throttle valve.

When the turbo-generator is shut down, a gradual collection of water in the steam line/turbine casing is modelled. Before start of cold turbo-generator the main steam line and turbine casing must be drained for water.

If the turbo-generator is started with much water present in the steam line, “water strike” will occur. This can severely damage the turbine rotor, and is indicated by a turbine trip.

The Turbo generator is modelled with engine driven LO pump as well as an electric pump drawing from a LO tank and discharging to the Turbo alternator via a fresh water cooled cooler. Two filters

are provided, to allow one set to be used, and the other set on standby.

Water ingress into the lubricating oil sump is modelled. Hence the turbo-generator lube oil tank should be drained off regularly and new oil added. Very low/high lube. oil temperature or very high water content will reduce the lubrication ability of the oil and cause rotor instability and possible turbine trip (high vibration trip).

Sealing steam for the glands is provided from the main inlet line, via a pressure reducing valve. The sealing steam drains exhaust to the main condenser.

The turbo-generator is protected by a separate safety system, and trip signal is given on the following conditions:

- high condenser hotwell water level
- high condenser pressure (low vacuum)
- high boiler water level
- turbo-generator overspeed
- low lub.oil pressure
- rotor water strike
- high vibration (due to cold start)
- water carry over
- high rotor vibration (due to poor lubrication)
- turning gear engaged

All trips must be manually reset before the turbo-alternator can be started.

**Turbo generator operation**

To start the turbo alternator. When steam is available at 7bar either from the oil fired boiler or the exhaust gas boiler then :-

1. MD 01; open seawater to steam condenser (V00673)
2. MD 85; start Main Condensate pump R 04721 and No 1 vacuum pump R 04720
3. MD 86; Set V04608 (T/G select valve) to oil fuel boiler
4. MD86; Open the following valves
  - steam line drain (V04657),
  - Sealing steam outlet (V04655),
  - turbo generator outlet to main condenser (V04660),
  - LO Filter No 1 (V04668)
  - LO cooling water shutoff valve (V04661)
  - Sealing steam valve (V04656)
5. MD86; Check the level and water content of the turbo generator. Drain and refresh as required.
6. MD86; Place Lube oil pump in AUTO.
7. MD86; Engage the turning gear for about 1 minute. On disconnection reset the turbine trip.
8. MD86; Open the turbo generator emergency stop valve (V04652) to 15%.
9. MD86; The Turbo generator should start to roll slowly. Let the turbine rotate for 2 minutes at this speed.
10. MD86; Continue to open the valve very slowly, up to 40% over 15 minutes.
11. MD86; Once the machine is up to speed (6400 rev/min) the emergency stop valve should be opened to 100% and steam line drain (V04657) closed.

12. MD86; Monitor all temperatures and pressures to ensure no alarms are active. The turbo generator can now be put on electrical supply.

It is important that the turbine is started slowly. This is to reduce thermal tension during start up. If the turbine speed is taken up too fast, high vibration will occur and the turbine will trip.

To stop the turbo alternator

1. MD70; Ensure the turbo alternator is not supplying electrical load. If so open the circuit breaker using the procedure within the electrical section.
2. MD86; Slowly close the emergency stop valve (V04652) to 20% open over 3 minutes. This will remove instability within the steam supply system.
3. MD86; open the steam line drain (V04657)
4. MD86 After the turbo-alternator has cooled down (leave for 10 minutes), close the emergency stop valve (V04652).
5. MD86; After the turbo-alternator has stopped, stop the electrical driven lubricating pump.
6. MD86; Close the following valves:
  - steam line drain (V04657),
  - Sealing steam outlet (V04655),
  - turbo generator outlet to main condenser (V04660),
  - LO Filter No 1 (V04668).
  - LO cooling water shutoff valve (V04661).
  - Sealing steam valve (V04656).

<This page is intentionally left blank>

00:03:28 Running	Picture MD 87	<b>Cargo Pump Turbines no. 1 &amp; 2</b>	Alarms	
			Silence	

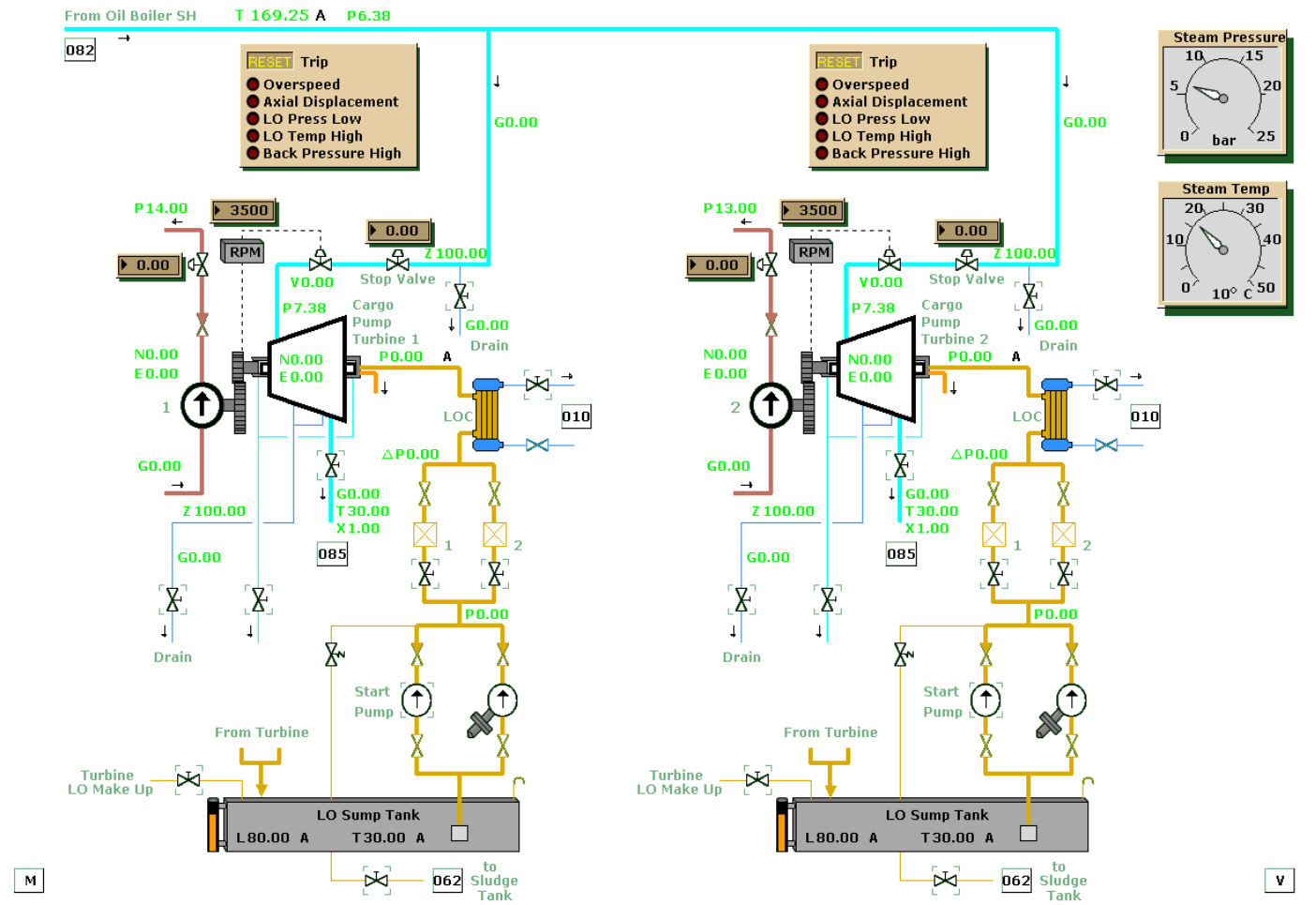

Unit Conversion	Message Log		Process Directory	Panel Directory	Process Overview	Back	Forward
-----------------	-------------	--	-------------------	-----------------	------------------	------	---------

## 5.23 Cargo Pump Turbines MD87

### General

Four Turbine driven Main Cargo Pumps are modelled. The cargo turbines should be run only when the oil-fired boiler is in operation. The steam will be superheated at 13 bar and approx. 410°C.

All turbines exhaust into the main condenser, held in vacuum conditions.

There is an electric driven LO start pump and engine driven LO pump fitted to each machine, each discharging to the turbine via fresh water cooled cooler. Two sets of filters are provided. One set will be operational, whilst the other used as standby.

The turbine speed is selectable and both the pump discharge pressure and the discharge Valve opening can be set according to load/rate of flow required.

There is modelled a simple safety system for the cargo turbines (common for all turbines), and cargo turbine trip is given on the following conditions:

- Overspeed
- rotor axial displacement (by water strike)
- LO pressure low
- LO temperature high
- high condenser pressure

Pressing the reset button resets the trip.

Note that the cargo pump turbines are less sensitive to low condenser vacuum than the turbo-generator. It is recommended not to operate the turbo alternator during cargo pumping operations.

### Cargo pump operation (procedure will use the start for No. 1 turbine)

1. MD87; Open the following valves
  - Line drain valve
  - Casing drain valve
  - Gland steam outlet valve
  - Exhaust shut off valve to condenser
  - Lube Oil Filter inlet Valve
  - LO Cooler freshwater Valve
2. MD87; The manual Lube Oil pump is now started.
3. MD87; The steam stop valve is now opened from 1 upwards slowly as the turbine begins to run up to speed. Increase to a value of 20 over 5 minutes.
4. MD87; When the rotor speed reaches 3500 rev/min, the steam stop valve can be opened fully and the two drain valves closed.
5. MD87; The speed value of the turbine can be increased as required up to 6000 rev/min (NB 6177 rpm equates to about 1500 rpm of pump speed.)
6. MD82; Monitor the boiler level and steam pressure during the load up of the cargo pump.



7. MD80; Change over feed pumps to operate the aux feed water pump
8. MD85; Change over the condensate pumps to operate the aux condensate pump
9. MD87. The pump discharge valve can be opened to load up the pump.
10. MD87; The pump back pressure can be adjusted on the 'Variable Page' to set the loading on the pump. This will modelled the static back pressure at the ship's manifold. A low back pressure can overload the turbine, whereas a high back pressure will prevent cargo pumping.

When one cargo turbine has been started, a small pause should be made before start of the next turbine to permit the boiler system to recover from the shock caused by the sudden steam load increase. With all turbines in operation, careful attention should be paid to the boiler system, which is now working at its ultimate capacity limits.

Cargo pump operation (procedure will stop No. 1 turbine)

1. MD87; Gradually close the cargo pump outlet valve to halt cargo pumping operations
2. MD87; Once cargo pumping has stopped, close the steam stop valve slowly to 0%
3. MD87; Start the manual lube oil pump
4. MD87; Open the following valves
  - Line drain valve
  - Casing drain valve
5. MD87; Close the following valves after 5 minutes
  - Line drain valve
  - Casing drain valve
  - Gland steam outlet valve
  - Exhaust shut off valve to condenser
  - Lube Oil Filter inlet Valve
  - LO Cooler freshwater Valve
6. MD87; Stop manual Lube Oil pump.
7. MD80/85; If all cargo operations are halted, change over to the main boiler feed pump on MD80, and the main condense pump on MD85.

<This page is intentionally left blank>

00:03:33 Running	Picture MD 89	<b>Ballast Water System</b>	Alarms	
			Silence	

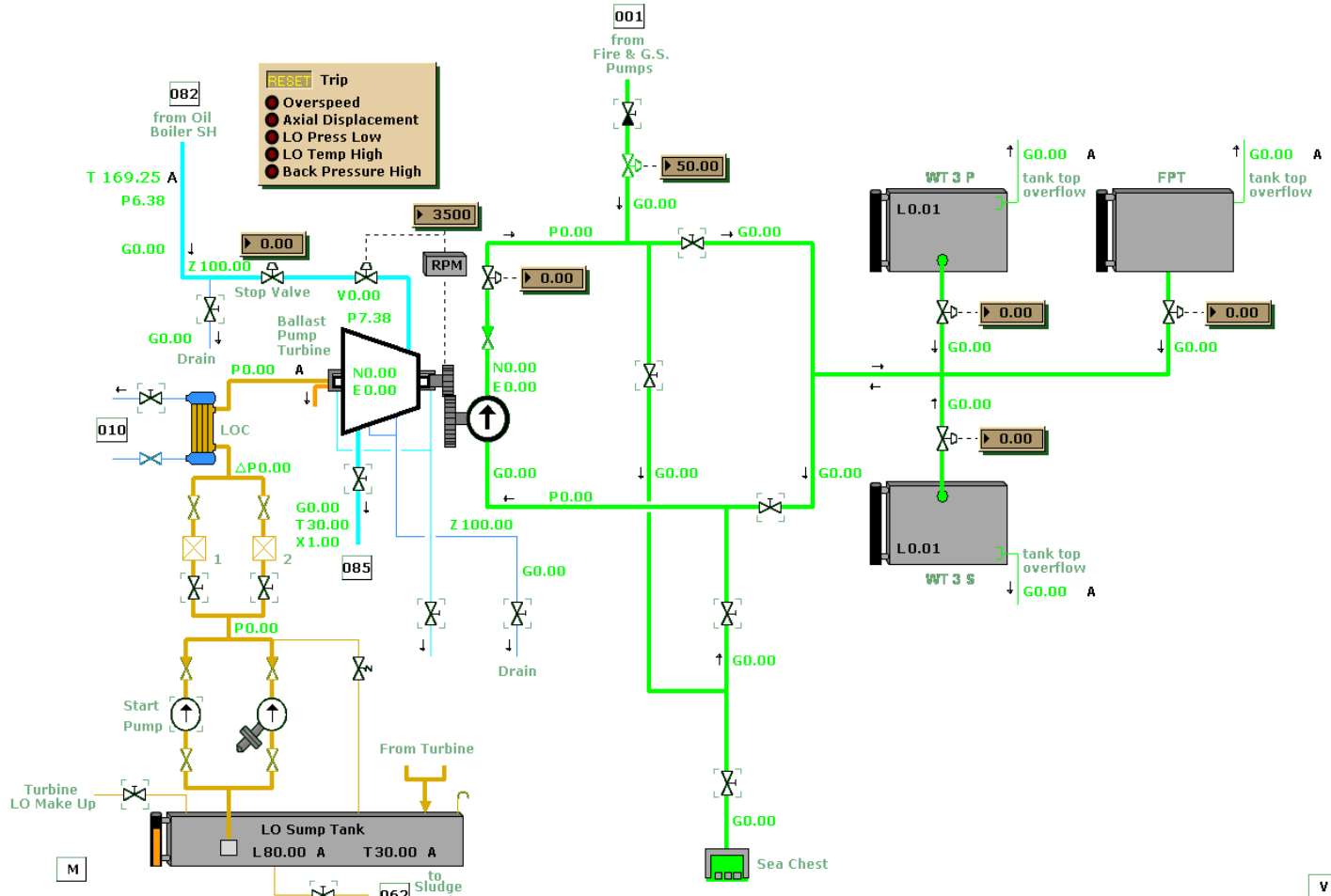

ERS - MC90-V 2.2.9999.0353 (01)

Unit Conversion	Message Log		Process Directory	Panel Directory	Process Overview	Back	Forward
-----------------	-------------	--	-------------------	-----------------	------------------	------	---------



## 5.24 Ballast Water System MD89

### General

The vessel can be ballsted from the general service pumps.

For ballast operations during cargo discharge the main ballast pump should be used.

One turbine driven ballast pump is modelled. The ballast turbine should be run only when the oil-fired boiler is in operation. The turbine exhaust into the main condenser, held at vacuum conditions.

There is an electric driven LO start pump and engine driven LO pump fitted, each discharging to the turbine via fresh water cooled cooler. Two sets of filters are provided. One set will be operational, whilst the other used as standby.

The turbine speed is selectable and the pump discharge pressure and the discharge Valve opening can be set according to load/rate of flow required.

There is modelled a simple safety system for the ballast turbine, and turbine trip is given on the following conditions:

- Overspeed
- rotor axial displacement (by water strike)
- LO pressure low
- LO temperature high
- high condenser pressure

Pressing the reset button resets the trip.

### Ballast pump operation (START)

1. MD89; Open the following valves
  - Line drain valve
  - Casing drain valve
  - Gland steam outlet valve
  - Exhaust shut off valve to condenser
  - Lube Oil Filter inlet Valve
  - LO Cooler freshwater Valve
2. MD89; The manual Lube Oil pump is now started.
3. MD89; The steam stop valve is now opened from 1 upwards slowly as the turbine begins to run up to speed. Increase to a value of 20 over 5 minutes.
4. MD89; When the rotor speed reaches 3500 rev/min, the steam stop valve can be opened fully and the two drain valves closed.
5. MD89; The speed value of the turbine can be increased as required up to 6000 rev/min (NB 6177 rpm equates to about 1500 rpm of pump speed.)
6. MD82; Monitor the boiler level and steam pressure during the load up of the ballast pump.
7. MD89; The pump is set to fill or discharge the ballast tanks are required. Note that the opening on the ballast tanks can be selected to ensure that the ballast tank is filled or emptied at the required rate. This will control the vessel's trim and list
8. MD89. The pump discharge valve can be opened to load up the pump.



---

**Ballast pump operation (STOP)**

1. MD89; Gradually close the ballast pump outlet valve.
2. MD89; Close all the ballast system valves
3. MD89; Once ballast pumping has stopped, close the steam stop valve slowly to 0%
4. MD89; Start the manual lube oil pump
5. MD89; Open the following valves
  - Line drain valve
  - Casing drain valve
6. MD89; Close the following valves after 5 minutes
  - Line drain valve
  - Casing drain valve
  - Gland steam outlet valve
  - Exhaust shut off valve to condenser
  - Lube Oil Filter inlet Valve
7. LO Cooler freshwater Valve
8. MD89; Stop manual Lube Oil pump.

<This page is intentionally left blank>

00:03:35 Running	Picture MD 91	<b>Inert Gas Plant</b>	Alarms	
			Silence	

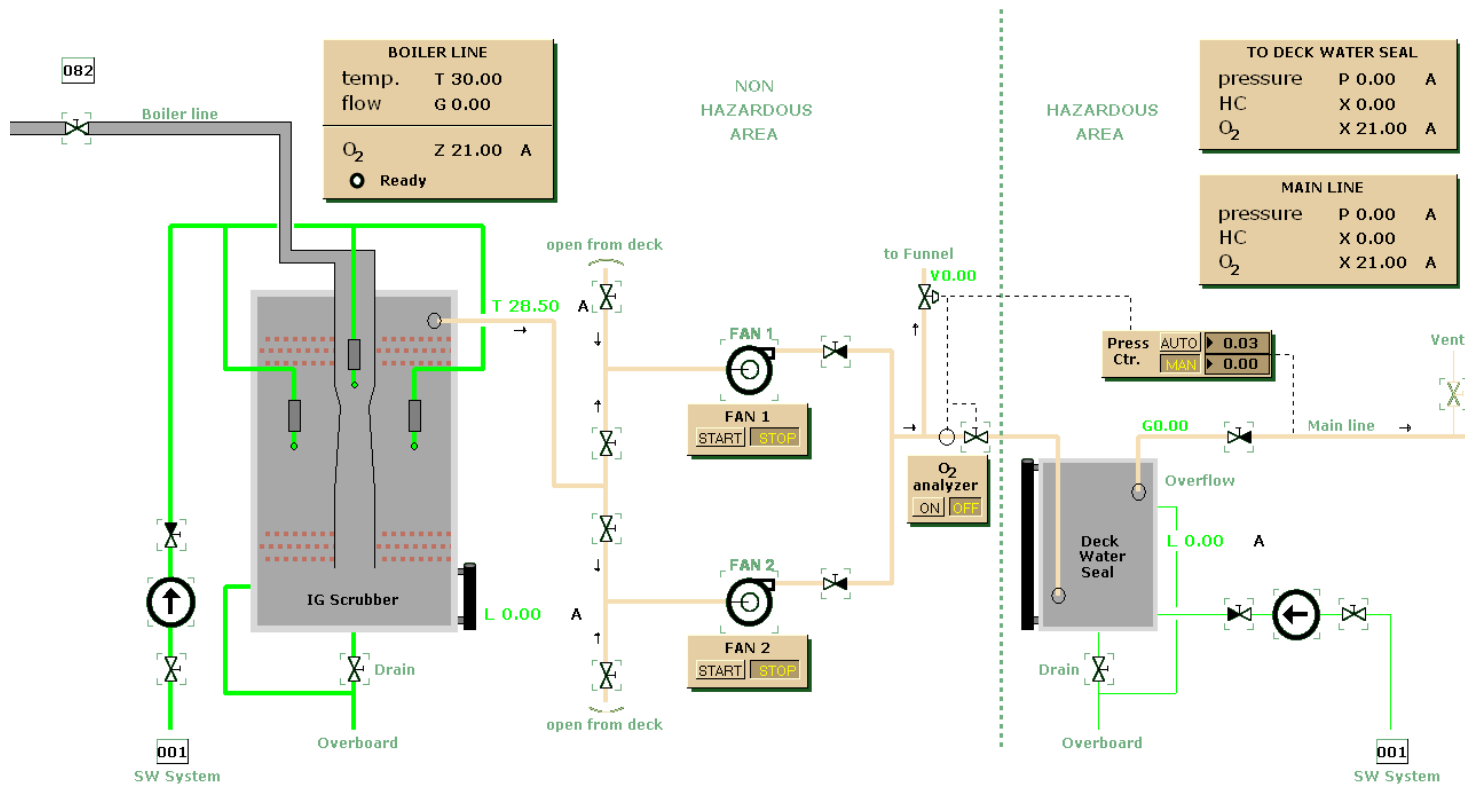

v  
 ERS - MC90-V 2.2.9999.0353 (01)

Unit Conversion	Message Log			Process Directory	Panel Directory	Process Overview	Back	Forward
-----------------	-------------	--	--	-------------------	-----------------	------------------	------	---------

## 5.25 Inert Gas Plant MD91

### General

The system is modelled with an oil fired boiler where flue gas is taken from the uptake and directed through the scrubber, fans and deck water seal to the main inert gas deck line. The capacity of the inert gas plant is approximately 40,000 m<sup>3</sup>/hour, provided sufficient flue gas is available from the boiler.

The scrubber tower has a dedicated seawater supply pump. This pump would operate at all times when the scrubber unit is used. The scrubber washes and cools the flue gas in order to reduce soot and SO<sub>2</sub> content. The outlet of the scrubber feeds the suction of the inert gas fans. Only one fan is required to be operated at any time.

The inert gas then passes through an oxygen analyser and associated controls before entering the deck seal. The deck seal provides one of the two non return valves that are mandatory in inert gas systems, to isolate the engine room from the hazardous deck area. The deck seal water level is maintained by a dedicated sea water pump. The pump is only operated when the deck level falls. A reduction in deck seal level is modelled, and is dictated by the carry over of the deck seal water during inert gas system operation. Inert gas passes through the non-return deck shut-off valve into the deck main.

The oxygen content will vary with the boiler load, and the setting of the oxygen controller within the boiler combustion. In order to avoid inert gas exceeding 5% O<sub>2</sub> entering the cargo tanks, the gas supply valve will trip and vent the flue gas to the funnel.

Another valve controlling the mainline pressure will also regulate the main line deck pressure to the tanks by venting to the funnel.

For cargo tank ventilation with fresh air, the system can be used by opening inert gas suction from the deck rather than the scrubber supply.

### Operation (Start-up of system)

1. MD01; Ensure the sea water inlet valve on either the high or low suction is open.
2. MD91; Open the scrubber tower sea water valves and start the pump to establish a seawater flow through the scrubber tower. Ensure the scrubber tower drain is closed
3. MD91; Ensure the inert gas fans fresh air suction valves from deck are closed
4. MD91; Check the level of the deck seal. If low, then open the valves and start the pump to fill the deck seal with seawater. Stop the pump and shut the valves when the level reaches 0.5m.
5. MD84; Check that the boiler is firing under stable load, and with an oxygen controller setting of 3.0%
6. MD91 Open the Shut-off Valve on the flue gas from the boiler supply line.
7. MD91; Switch on the Oxygen analyser and put the Pressure Controller on Manual. Input a Value of 100 to open the flow only to the funnel.



8. MD91; Open selected fan suction from scrubber tower, and discharge valve and start fan.
9. MD91; Open the vent on the deck main
10. MD91; When the Oxygen reading from the boiler line is below 4%, open the deck isolating valve.
11. MD91; Switch the Pressure Controller to AUTO, with a setting of 0.03bar.
12. MD91; Once the oxygen level has stabilised within the main line, close the vent on the deck main, and open the supply to the cargo tanks
13. MD91; Monitor and maintain the deck water seal level as required by starting the deck seal pump.

Note the flow of inert gas to the cargo tanks is a function of the cargo discharge rate (from the cargo oil pumps) and the inert gas pressure.

#### **Operation (Clean air ventilation of cargo tanks)**

1. MD01; Ensure the sea water inlet valve on either the high or low suction is open.
2. MD91; Close the outlet gas valves from the scrubber tower
3. MD91; Check the level of the deck seal. If low, then open the valves and start the pump to fill the deck seal with seawater. Stop the pump and shut the valves when the level reaches 0.5m.
4. MD91; Open selected fan suction from the deck, open discharge valve and start fan.
5. MD91; Open the vent on the deck main
6. MD91; Switch the Pressure Controller to AUTO, with a setting of 0.03bar.
7. MD91; Once the oxygen level has stabilised to over 20% within the main line, close the vent on the deck main, and open the supply to the cargo tanks
8. MD91; Monitor and maintain the deck water seal level as required by starting the deck seal pump.

<This page is intentionally left blank>

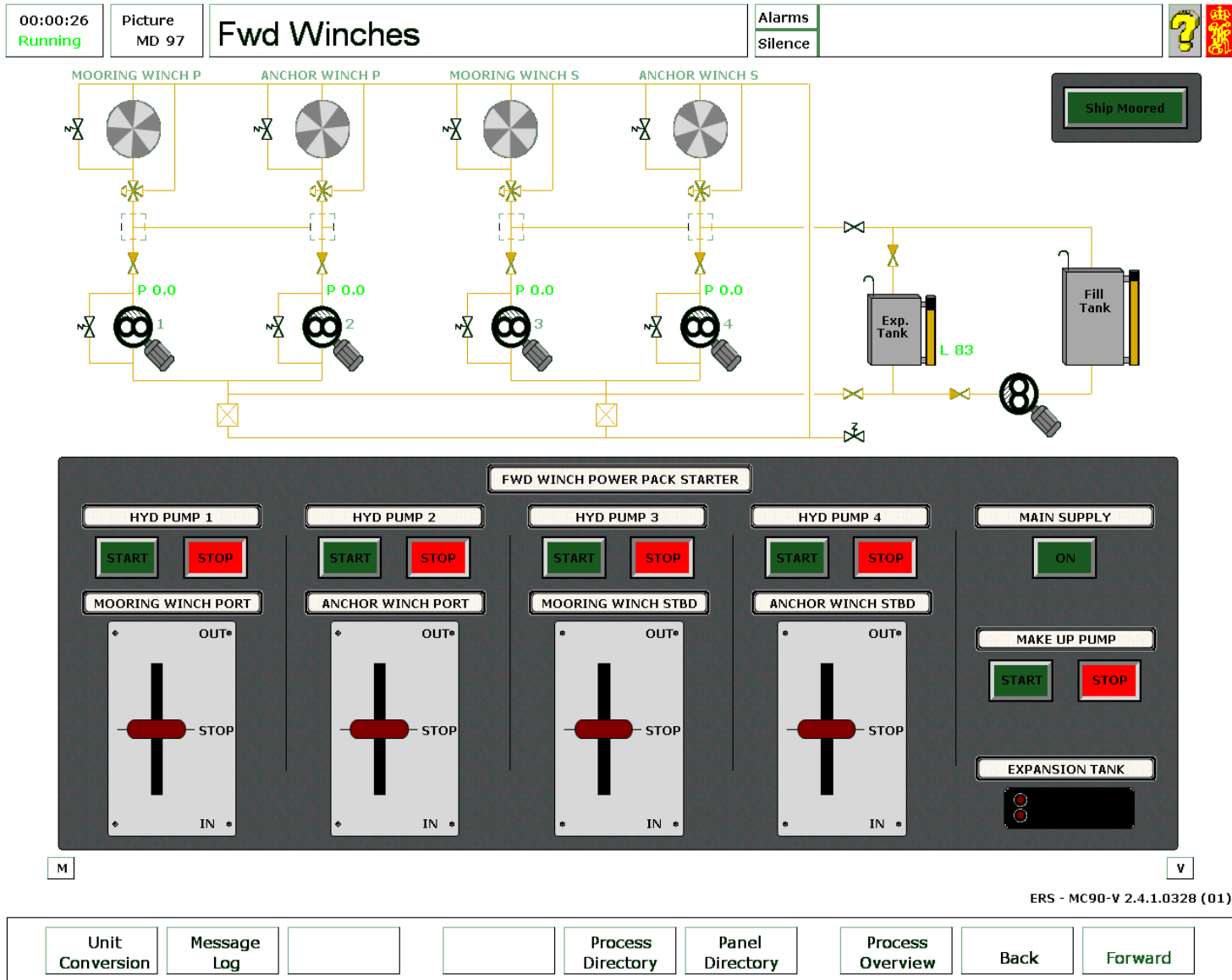



## 5.26 Deck Machinery MD97

### General

The vessel is equipped with four low pressure hydraulic winches forward and aft. There are two anchor winches and two mooring winches forward and four mooring winches aft. The power pack is sized to operate two windlasses or four winches at specified capacity simultaneously.

The Hydraulic Power Pack unit consisting of four electric motor driven hydraulic pumps, filter, valves, pressure gauges, drain valve, make up pump, servo unit, and expansion tank with level switches.

Working pressure:	64 bar.
El. power:	4 x 152 kW.
Oil delivery:	4 x 1313 l/min.

Speed and rotation direction can be locally operated.

The pumps are screw type.

Typical return pressure:	3 Bar
Expansion tank volume:	140 l

The package consist of a Group starter with local start / stop buttons, isolating switch, and running light. Low level alarm and low/low level alarm with automatic stop and extension to AMS.

### 5.26.1.1 Operation

#### *Preparation*

Check content in hydraulic oil tanks, refill if necessary.

Check that change-over valves are in correct position (open for flow).

Check ship status (moored in Port?)



***Start procedure***

Connect main power supply.

Set the change over valves to correct position.

Start hydraulic pump(s) locally from Powerpack starter Panel.

Throttle is moved in order to run the winch in or out.

Normal operation is one pump for each winch. Change over valves gives the possibility for selection two pumps for one winch, in order to increase winch speed. By running one winch with two pumps at full speed and without load will cause overspeed damage of the winches after some time.

It is also possible to interlock in order to select two pumps in parallel with two winches.



<This page is intentionally left blank>

00:01:56  
Running

Picture MD 56

## Ship Propulsion

Alarms  
Silence



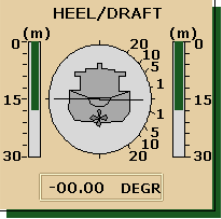

HEEL/DRAFT

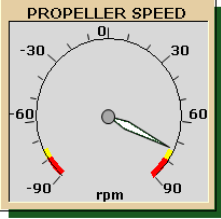

-00.00 DEGR

PROPELLER SPEED



N 74.01

SHIP SPEED

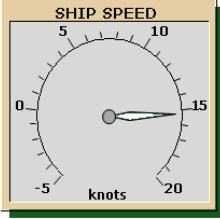

N 15.37

SHAFT POWER

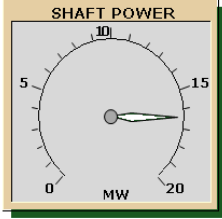

E 16.52

TRIM/DRAFT

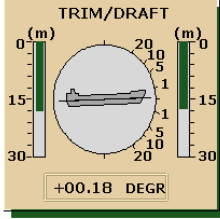

+00.18 DEGR

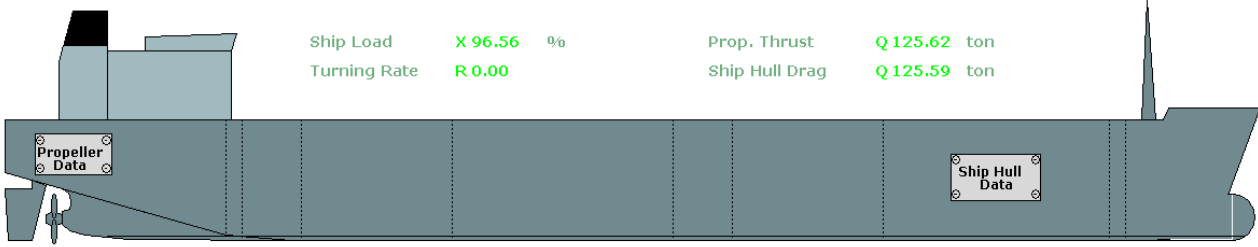

Ship Load X 96.56 %

Turning Rate R 0.00

Prop. Thrust Q 125.62 ton

Ship Hull Drag Q 125.59 ton

Rudder Position

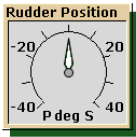

X 0.00

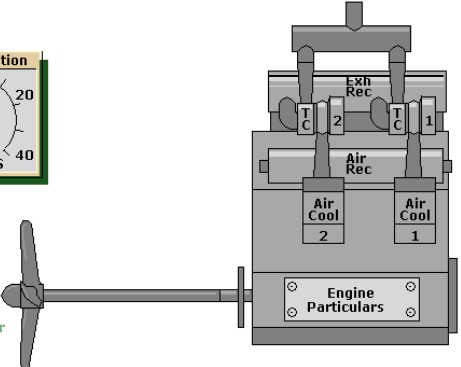

Propeller Pitch X 0.90

ME Speed N 74.01 rpm

ME Fuel Link X 56.75 %

ME Shaft Torque Q 2162.0 kNm

ME Fuel Consumption G 3.16 ton/h

ME Spec Fuel Oil Cons. G 184.56 g/kWh

ME NOx Content Z 15.05 g/kWh

ERS - MC90-V 2.2.9999.0353 (00)

Unit Conversion

Message Log

Process Directory

Panel Directory

Process Overview

Back

Forward



## 6 SIMULATOR & SHIP MODEL PARTICULARS

### 6.1 Propeller and Ship Model Characteristics

The propeller characteristic is realistically modulated. The propeller torque and thrust depend on ship speed, propeller revolution, and propeller pitch and rudder deflection. The hull resistance is set for a typical VLCC. It is made dependent on ship speed, ship draft, heel and trim, depth of water, weather condition (wave/wind) and the hull's degree of fouling.

The basic ship speed response-constant is correctly modulated in dependence of load condition. By using the "Ship Dynamics" from the Operating Condition picture, the instructor can change the apparent speed response to save time:

- 1 times true response
- 2 times true response
- 4 times true response

The steady state thrust or the time scale does not influence propulsion power!

The hull model includes dynamic description of the ship's movement ahead, its speed and rate of turn, its yawing, rolling and pitching etc. The hull drag force includes water resistance due to waves, wind, and ice. The weather condition sets the general level of wave disturbance. The wind force is specified by mean wind speed and wind direction.

The ice resistance is composed of one steady and one dynamic component. If the ship gets stuck in the ice, "ice breaking" can be tried. Reverse the ship some ship lengths and then ram with full power towards the ice edge.

The influence of the weather condition, set by the instructor, is modulated in three ways:

- The waves' effect on the propeller is simulated by adding the hydrodynamic propeller torque random disturbances (low-pass filtered, white noise). The rpm will vary somewhat and the AutoChief system will be disturbed in its speed controlling function.
- The pitch and roll movement of the ship is simulated by adding the liquid level in the following tanks:
  - Fresh water expansion tank
  - ME lubrication oil sump tank
  - DG1 & 2 sump lubrication oil tanks
  - HFO service tanks
  - DO service tank
  - Engine room bilge well
  - Stern tube LO tanks
  - OF boiler steam drum



---

The breaking effect of the waves on the ship speed is simulated by increasing the propulsion resistance. The ship speed will drop and the main engines will thus be heavier loaded.

The water depth can be specified and the "shallow water" effect demonstrated. The effect is noticeable only if the depth is less than 2-3 times ship draft.

A Bow Thruster can be operated from the bridge (Instructor's Station). The thruster pitch is adjustable. Note that the bow thruster force will decrease at increasing speed ahead and at full speed the bow thruster will have no influence.

## 6.2 Ship Load MD57

All tanks are assumed prismatic in form (tank masses proportional to level). The following main tanks are included:

- FO settling tanks
- FO service tanks
- Spill oil tank
- FO bunker tanks
- DO storage tank
- Lubrication oil tanks

Storage tanks are modelled as masses entered by the instructor, and set the boundaries for the simulated systems.

Ballast tanks are represented on this ship as followed:

- 2 x 1 Ballast wing tank
- 1 Fore peak tank

The load in cargo tanks can be altered by the operator or the instructor from Variable Page 5702, Ship Load Condition.

### Ship Load override

The instructor can override the actual calculated load of the ship by changing the "SHIP LOAD" parameters from page 9002, "Sim Control; External Conditions:"

X07015      0(M)= load set by hull program  
                 1(P)= load set by "potentiometer"X06317 at the same  
                 page (pot meter input)  
                 2(F)= full loaded ship (100% dwt)  
                 3(E)= light ship (20% dwt)



### 6.3 Ambient Temperatures

The ambient sea water and air temperature is adjustable through the variable page 9002 "SIM CONTROL; External Conditions". The sea water temperature effects the operational condition of all FW, lubricating oil and air coolers. Changes in the sea water temperature will over time impact the temperature in various tanks, on condition they were left without heating.

The air temperature in the engine room depends on the total power from the main auxiliary engines, ambient air temperature and the number of engine room ventilation fans in operation. In case an engine room fire is simulated, the temperature will increase rapidly. The air temperature in the engine room also effects the scavenging air temperature of the diesel engines.

A simple model of the engine control room (ECR) air conditioning system is included. If the air conditioning system is turned off or has failed, the engine control room temperature will gradually approach machinery space temperature. Fire in the engine room will lead to an overload of the air conditioning system, and will finally fail.



## 6.4 Auto Pulsar System

### Description

To facilitate easy test of controller performance in various systems, the auto pulsar system is included. The auto pulsar enables auto-change of set point in intervals. The engine room systems with auto pulsar functionality vary with the simulator model but are found under the SIM CONTROL variable pages.

The following settings are typical for a low speed engine model:

Sea water temp control:	Default = 20 degC	Auto pulsar = 16 degC
Low temp fresh water temp control:	Default = 34 degC	Auto pulsar = 30 degC
High temp fresh water temp control:	Default = 80 degC	Auto pulsar = 75 degC
Lubrication oil temp control:	Default = 45 degC	Auto pulsar = 41 degC
Main engine command:	Default = 100 %	Auto pulsar = 70 %
FO Viscosity control:	Default = 15 cSt	Auto pulsar = 12 cSt
Boiler level control:	Default = 0 mm	Auto pulsar = -50mm
Boiler pressure control:	Default = 16 bar	Auto pulsar = 15 bar

### Operation

Select SIM CONTROL variable page.

Set Pulsar system active (1).

Set one or more of available systems to auto pulsar active (1).

Observe that controller instantly changes set-point and the counter starts counting down from default time setting (seconds).

To switch off auto pulsar, type 0.



---

The following settings in seconds are typical for the low speed models:

Sea water temp control:	Default = 180 seconds ON/180 seconds OFF
Low temp fresh water temp control:	Default = 180 seconds ON/180 seconds OFF
High temp fresh water temp control:	Default = 180 seconds ON/180 seconds OFF
Lubrication oil temp control:	Default = 120 seconds ON/120 seconds OFF
Main engine command:	Default = 300 seconds ON/300 seconds OFF
FO Viscosity control:	Default = 120 seconds ON/120 seconds OFF
Boiler level control:	Default = 300 seconds ON/300 seconds OFF
Boiler pressure control:	Default = 240 seconds ON/240 seconds OFF

### **Useful Info**

Changing ON and OFF time is done by typing desired time as a negative value.

Note that some simulator models may have counter range 0-99, this means that any number is multiplied by 10 to get the time in seconds (setting 12 is equal to 120 seconds).